

# BrightEye™

## BrightEye™ 83 and 83-F

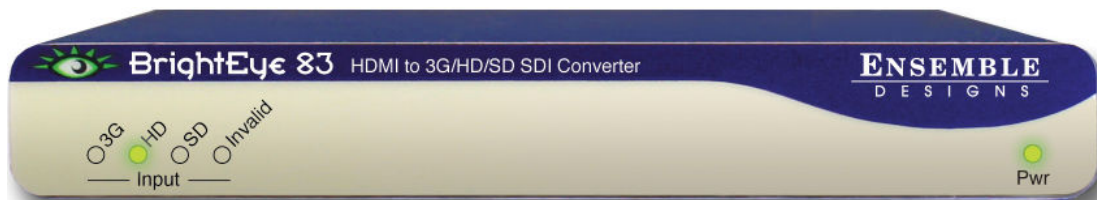

### **HDMI to 3G/HD/SD SDI Converter and HDMI to Fiber 3G/HD/SD SDI Converter User Guide**

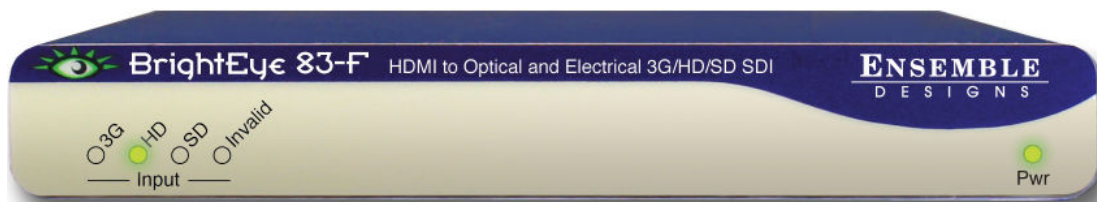

Revision 1.0 SW v1.2.0

**ENSEMBLE**  
DESIGNS

*Purveyors of Fine Video Gear—Loved by Engineers Worldwide*

*“Regardless of how quickly we need to take Mitto to air, it works famously every time. And it looks spectacular. When we covered the blizzards last winter, all of our user-generated content submissions and Skype came through Mitto.”*

*~ John Schilberg, VP of Technology, Griffin Communications, KWTW, KOTV and KQCW*



BrightEye — palm sized video and audio conversion, HD up/down/cross conversion, scan conversion and test signal generators with 3G, HD, SD, ASI, HDMI video, audio and optical choices.

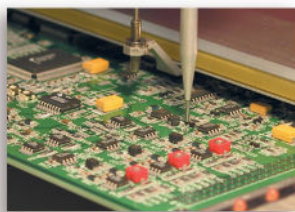

Everything is made at our factory in Nevada City, California.



Shipped with care to television broadcasters and video facilities all over the world.



And consider our Avenue product line when you need a modular system.



Come on by and visit us.  
Drop in for lunch and a tour!

## Who is Ensemble Designs?

### By Engineers, For Engineers

In 1989, a former television station engineer who loved designing and building video equipment, decided to start a new company. He relished the idea of taking an existing group of equipment and adding a few special pieces in order to create an even more elegant ensemble. So, he designed and built his first product and the company was born.

### Focused On What You Need

As the company has grown, more former TV station engineers have joined Ensemble Designs and this wealth of practical experience fuels the company's innovation. Everyone at the company is focused on providing the very equipment you need to complete your ensemble of video and audio gear. We offer those special pieces that tie everything together so that when combined, the whole ensemble is exactly what you need.

### Notably Great Service for You

We listen to you – just tell us what you need and we'll do our best to build it. We are completely focused on you and the equipment you need. Being privately held means we don't have to worry about a big board of directors or anything else that might take attention away from real business. And, you can be sure that when you call a real person will answer the phone. We love this business and we're here to stay.

### Bricks and Mortar of Your Facility

The bricks and mortar of a facility include pieces like up/downconverters, audio embedders, video converters, protection switches, routers and SPGs for SD, HD and 3Gb/s . That's what we're focused on, that's all we do – we make proven and reliable signal processing and infrastructure gear for video facilities worldwide, for you.



# Contents

<b>Product Overview</b>	<b>4</b>
Capabilities Overview for BrightEye 83 and BrightEye 83-F	4
Free Software Upgrades Forever	4
<b>Functional Description and Block Diagram</b>	<b>5</b>
<b>Applications</b>	<b>6</b>
<b>Rear Connectors</b>	<b>7</b>
Power Connection	8
HDMI Connection	8
USB Connection	8
SDI Outputs	8
Inputs and Outputs	9
<b>Operation</b>	<b>10</b>
Front Panel Indicators	10
<i>Status Indicators</i>	10
Using the BrightEye Control Application	11
<i>Input Menu</i>	12
<b>Troubleshooting</b>	<b>14</b>
<i>The Input Menu status displays “Unknown” and the Invalid Input LED is illuminated on the front panel</i>	14
<i>No Input LED is illuminated on the front panel, the Power LED is illuminated</i>	14
<b>Software Updating</b>	<b>15</b>
<b>Warranty and Factory Service</b>	<b>15</b>
Warranty	15
Factory Service	15
<b>Specifications for BrightEye 83 and BrightEye 83-F</b>	<b>16</b>
<b>Glossary</b>	<b>17</b>

## Product Overview

BrightEye 83 and BrightEye 83-F convert HDMI to 3G, HD or SD SDI. These units are convenient for broadcast video cameras and other sources with an HDMI output. BrightEye 83 and 83-F pass embedded audio and support all 8 audio channels on the HDMI input.

BrightEye 83 converts HDMI to standard definition video signals and 3 Gb/s and 1.5 Gb/s high definition signals.

BrightEye 83-F presents both electrical and optical serial digital outputs. The optical output can drive single mode fiber to a distance of 20 kilometers. With an optical launch power attenuator, multi-mode fiber can also be used.

Signal monitoring is provided on the front panel of the unit, and through the included BrightEye Mac and BrightEye PC software.

In compliance with the licensing restrictions on HDCP encrypted material, BrightEye 83 and 83-F cannot convert encrypted signals to SDI form.

A glossary of commonly used video terms is provided at the end of this user guide.

## Capabilities Overview for BrightEye 83 and BrightEye 83-F

- HDMI to 3G, HD and SD SDI Converter
- Optical and Electrical SDI Outputs with BrightEye 83-F
- Use with Cameras and Other Sources that have an HDMI Output
- Passes Embedded Audio
- Supports all 8 Audio Channels on the HDMI Input
- Intuitive Front Panel Indicators
- Easy-to-use Mac and PC User Interface
- Rackmountable
- 5-Year Warranty and Free Software Upgrades

## Free Software Upgrades Forever

BrightEye Mac/PC software is included with each unit at no charge. Use BrightEye Mac/PC software to monitor and control a single BrightEye unit or any number of units connected to a USB hub. BrightEye Mac/PC software is not required as the BrightEye 83 and 83-F front panel controls are intuitive and provide signal monitoring. You can choose what type of monitoring and control is best for your facility.

BrightEye software is easily upgraded through the unit's USB port. Software upgrades are available at no charge for the life of the product and are conveniently downloadable at the following link:

[www.ensembledesigns.com/support/brighteye-support/brighteye-software](http://www.ensembledesigns.com/support/brighteye-support/brighteye-software)

## Functional Description and Block Diagram

As shown in the functional block diagram below, HDMI is fed to the BrightEye 83 or 83-F on an HDMI 1.3 connector. When a valid input is detected it is converted to 3G, HD or SD SDI. 8 channels of incoming audio are supported and embedded in the SDI outputs.

BrightEye 83 provides two electrical SDI outputs (BNC). BrightEye 83-F provides two electrical SDI outputs (BNC) and one optical output.

BrightEye 83 and 83-F are powered by a 12 volt DC universal power supply. This power supply can accept an input voltage between 90 and 230 volts, at 50 or 60 Hertz.

BrightEye 83 and 83-F use a standard IEC line cord and can be used anywhere in the world. It is normal for the converter to be quite warm to the touch when operating.

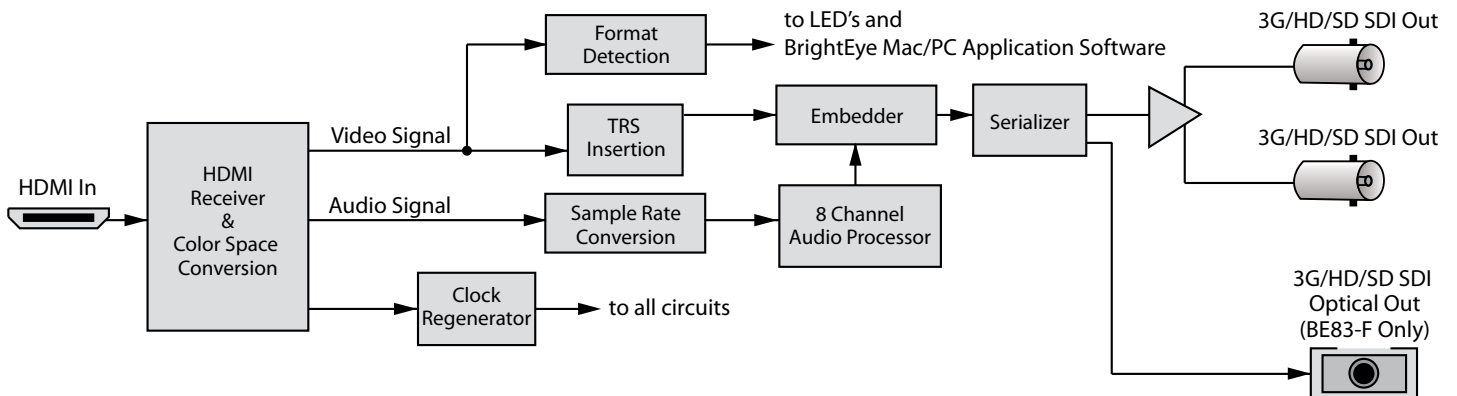

*BrightEye 83 and 83-F Functional Block Diagram*

## Applications

One useful application for the BrightEye 83 or 83-F is converting content from a receiver or media player to SDI video for use with a router or professional video monitor.

Refer to the application drawings below for examples of using BrightEye 83 or 83-F for this purpose.

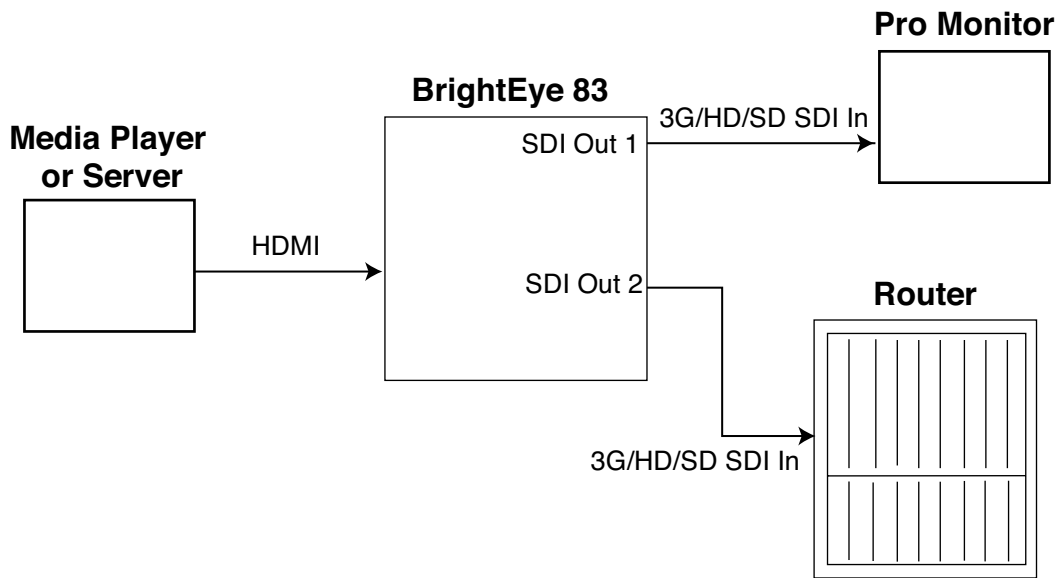

*BrightEye 83 HDMI to 3G/HD/SD SDI Conversion Example*

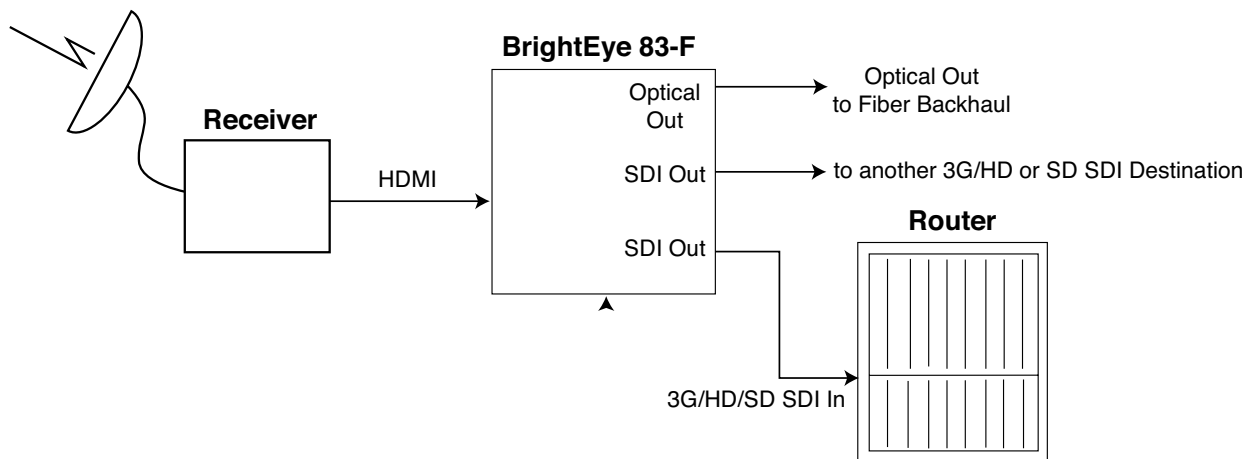

*BrightEye 83-F HDMI to Optical and Electrical Conversion Example*

## Rear Connectors

All connections to the BrightEye 83 and 83-F are made on the rear of the unit. Refer to the illustrations below for a snapshot reference. A more detailed explanation of the rear connectors follows.

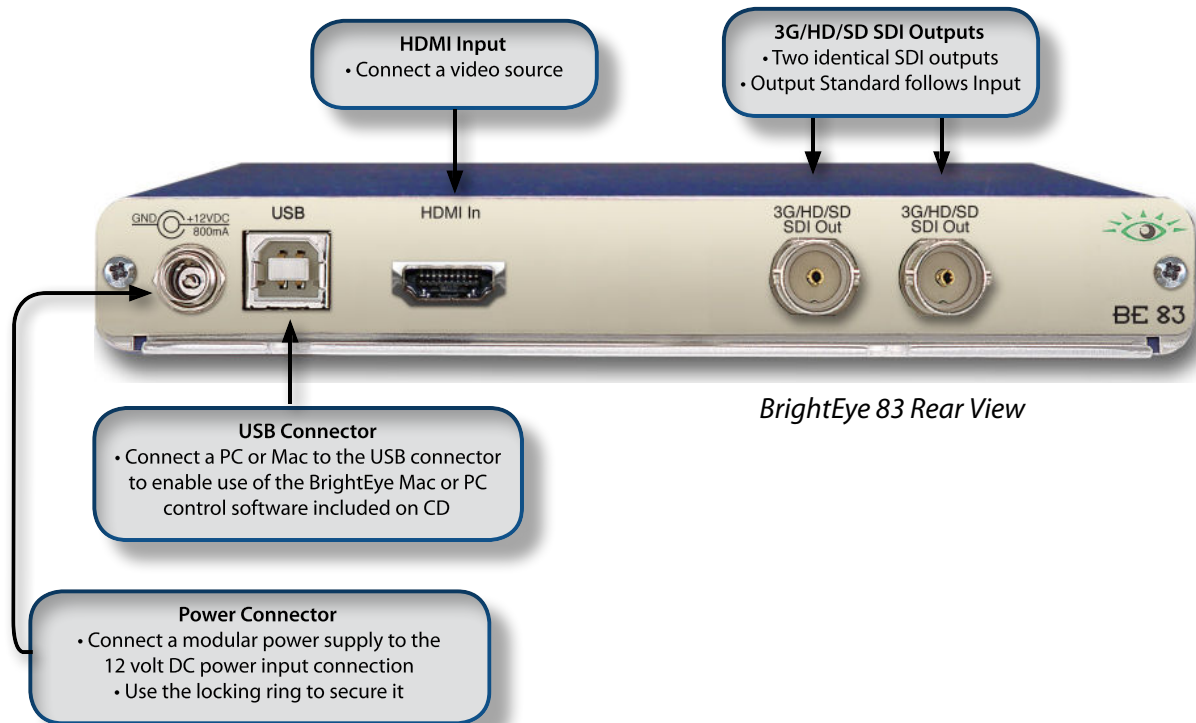

## Power Connection

Connect the modular power supply (ED part number 23118900) to the 12-volt DC power input connection on the far left of the unit. Use the locking ring to secure it.

## HDMI Connection

Connect your video source to the BrightEye 83 or 83-F HDMI Input.

## USB Connection

Your BrightEye 83 or 83-F comes with a USB cable, shown below. Connect the USB port to a PC or Mac running BrightEye software for more comprehensive monitoring and upgrades to the unit. BrightEye PC/Mac control application software is included on CD that came with your BrightEye, or the application can be downloaded for free at the following link:

[www.ensembledesigns.com/support/brighteye-support](http://www.ensembledesigns.com/support/brighteye-support)



*USB cable that is included with your BrightEye*

## SDI Outputs

The SDI Output BNCs output the same signal on both BNCs. The Output Standard follows the Input Standard. Connect to a video destination such as a router, production switcher, or broadcast monitor.



*Example of a BNC cable*



## Inputs and Outputs

- **HDMI In** – Connect your video source to the HDMI Input. BrightEye 83 and 83-F support all of the 3G, HD and SD standards listed in the chart in the “Using the BrightEye Control Application” on page 11.

**Note:** HDCP (High-bandwidth Digital Content Protection) is a content encryption system for HDMI. It is meant to prevent copyright content from being copied. Protected content, like a movie on a Blu-Ray disc is encrypted by its creator. Devices that want to display the protected content, like a television, must have an authorized key in order to decode the signal and display it. The entity that controls the HDCP standard strictly limits the kinds of devices that are allowed decryption keys. Devices that decrypt the content and provide an unencrypted copy are not allowed.

- **SDI Outputs** – Two identical SDI outputs are provided for feeding destinations that accept standard definition video signals and 3 Gb/s and 1.5 Gb/s high definition video signals.
- **Optical SDI Out (BrightEye 83-F Only)** – This output is a 3G, HD or SD SDI signal. It is the same signal that is on the electrical 3G/HD/SD SDI Out BNCs.

## Operation

Operation of the BrightEye 83 and 83-F is performed from the front panel or remotely from a networked PC with the BrightEye Mac/PC Control application software.

### Front Panel Indicators

The front panel of the converter, shown in the figure below, provides status indicators.



*BrightEye 83 Front Panel*

### Status Indicators

- **In (Input)** – The incoming format (**3G**, **HD**, or **SD**) will illuminate green when a valid HDMI input is detected on the **HDMI In** connector.

BrightEye 83 and 83-F support all of the 3G, HD and SD standards listed in the chart in the “Using the BrightEye Control Application” on page 11. The video format coming in on the HDMI connector is auto detected.

If an invalid or incompatible input signal is detected, **Invalid** will illuminate red. Possible reasons for this are:

1. The incoming signal is HDCP encrypted (see note below for an explanation of HDCP)
2. The incoming signal is an unsupported format, such as a computer resolution of 1024 x 768
3. The incoming signal is an unsupported refresh rate

**Note:** HDCP (High-bandwidth Digital Content Protection) is a content encryption system for HDMI. It is meant to prevent copyright content from being copied. Protected content, like a movie on a Blu-Ray disc is encrypted by its creator. Devices that want to display the protected content, like a television, must have an authorized key in order to decode the signal and display it. The entity that controls the HDCP standard strictly limits the kinds of devices that are allowed decryption keys. Devices that decrypt the content and provide an unencrypted copy are not allowed.

- **Pwr (Power)** – The power indicator illuminates green when the BrightEye unit has power and the internal voltage regulator is functioning correctly.

## Using the BrightEye Control Application

BrightEye Mac and PC Control application software is included on a CD with each unit and offers more comprehensive monitoring of your BrightEye 83 or BrightEye 83-F. BrightEye Mac/PC software is designed to allow you to monitor the BrightEye 83 or 83-F from a personal computer. Installation and instructions for using this software application are given in the PDF manual on the CD.

If the BrightEye 83 or 83-F is connected to a computer running BrightEye Mac/PC software, the Input menu is available for monitoring the unit. This menu is detailed on the following page.

## Input Menu

- **Input** – This menu provides a read-only status indication of input video presence. The video format coming in on the HDMI connector is auto detected and reported here. BrightEye 83 and 83-F support all of the 3G, HD and SD standards listed in the chart below.

3G	HD	SD	Other
3G 1080p/50	720p/50	SD 525	No Input
3G 1080p/59.94	720p/59.94	SD 625	Unknown
3G 1080p/60	720p/60		
	1080i/50		
	1080i/59.94		
	1080i/60		
	1080p/25		
	1080p/23.98		
	1080p/24		
	1080sF/25		
	1080sF/23.98		
	1080sF/24		

- **Unknown** – If the status indicator displays “**Unknown**”, the unit is detecting an invalid or incompatible input signal. Possible reasons for this are:
  1. The incoming signal is HDCP encrypted (see note below for an explanation of HDCP)
  2. The incoming signal is an unsupported format, such as a computer resolution of 1024 x 768
  3. The incoming signal is an unsupported refresh rate

**Note:** HDCP (High-bandwidth Digital Content Protection) is a content encryption system for HDMI. It is meant to prevent copyright content from being copied. Protected content, like a movie on a Blu-Ray disc is encrypted by its creator. Devices that want to display the protected content, like a television, must have an authorized key in order to decode the signal and display it. The entity that controls the HDCP standard strictly limits the kinds of devices that are allowed decryption keys. Devices that decrypt the content and provide an unencrypted copy are not allowed.

- **No Input** – If the status indicator displays “**No Input**”, the BrightEye is not detecting any input signal. Check your cabling connections:

**Note:** In this situation none of the Input LEDs on the front panel will be illuminated, and the Power LED will be illuminated.

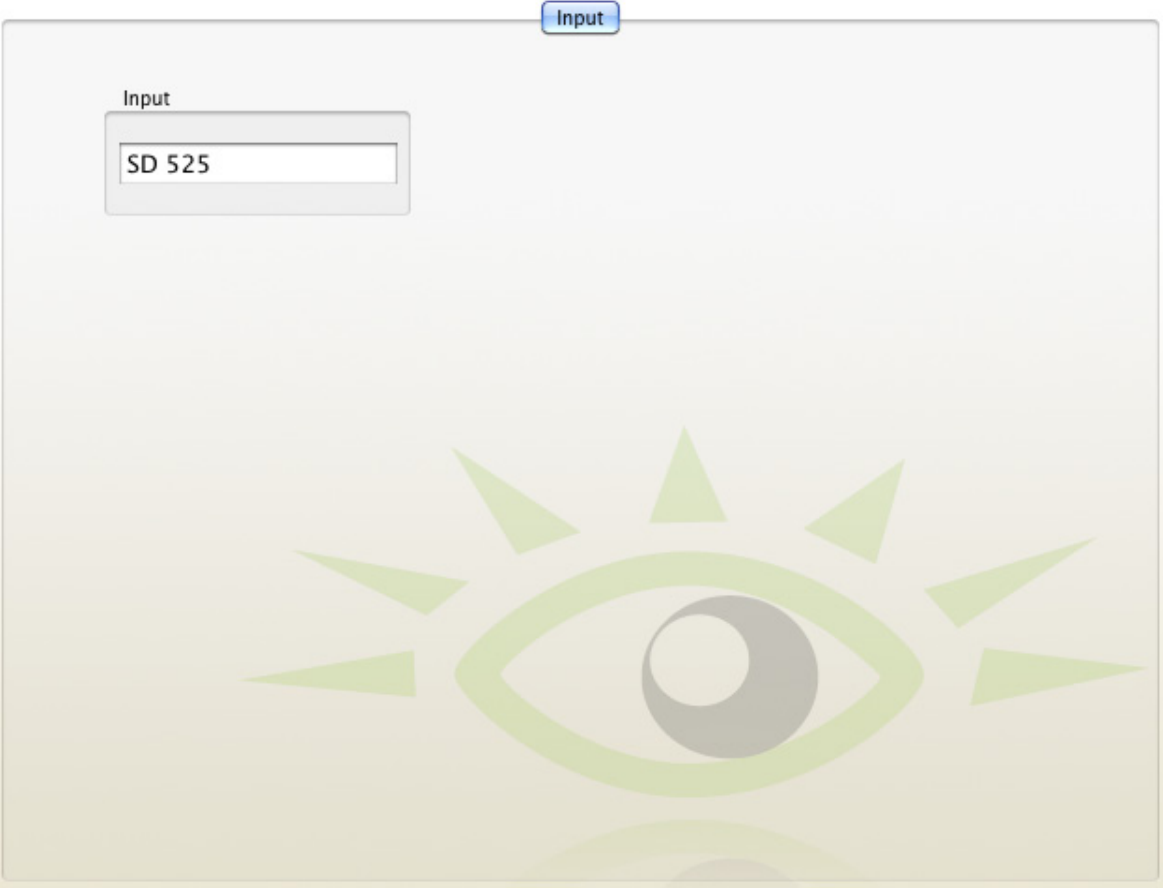

*BrightEye 83/83-F Input Menu*

## Troubleshooting

### **The Input Menu status displays “Unknown” and the Invalid Input LED is illuminated on the front panel.**

The **Input Menu** status in BrightEye Mac/PC will display “**Unknown**” and the **Invalid** Input LED on the front panel will illuminate red if:

1. The incoming signal is HDCP encrypted
2. The incoming signal is an unsupported format, such as a computer resolution of 1024 x 768
3. The incoming signal is an unsupported refresh rate

**Please Note:** HDCP (High-bandwidth Digital Content Protection) is a content encryption system for HDMI. It is meant to prevent copyright content from being copied. Protected content, like a movie on a Blu-Ray disc is encrypted by its creator. Devices that want to display the protected content, like a television, must have an authorized key in order to decode the signal and display it. The entity that controls the HDCP standard strictly limits the kinds of devices that are allowed decryption keys. Devices that decrypt the content and provide an unencrypted copy are not allowed.

### **No Input LED is illuminated on the front panel, the Power LED is illuminated.**

If no Input LED illuminated on the front panel but the Power LED is illuminated, the BrightEye is not detecting any input signal. Check your cabling connections:

**Note:** In this situation the **Input Menu** status in BrightEye Mac/PC will display “**No Input**”

## Software Updating

Software upgrades for BrightEyes are available free at the following link:

[www.ensembledesigns.com/support/brighteye-support/](http://www.ensembledesigns.com/support/brighteye-support/)

Use BrightEye Mac or PC software to install the software update into your BrightEye.

## Warranty and Factory Service

### Warranty

This module is covered by a five-year limited warranty. If you require service (under warranty or not), please contact Ensemble Designs and ask for customer service before you return the unit. This will allow the service technician an opportunity to provide any other suggestions for identifying the problem and to recommend possible solutions.

### Factory Service

If you return equipment for repair, please get a Return Material Authorization Number (RMA) from the factory first.

tel +1 530.478.1830

fax +1 530.478.1832

[service@ensembledesigns.com](mailto:service@ensembledesigns.com)

[www.ensembledesigns.com](http://www.ensembledesigns.com)

Ship the product and a written description of the problem to:

Ensemble Designs, Inc.  
Attention: Customer Service RMA #####  
870 Gold Flat Rd.  
Nevada City, CA 95959 USA

Be sure to put your RMA number on the outside of the box.

## Specifications for BrightEye 83 and BrightEye 83-F

### Input

Number	One
Type	HDMI 1.3, Type C connector
Format	Supports HDMI signals which map to the video standards listed below

### SDI Standards Supported

1080i (SMPTE 274M -4,5,6) 50, 59.94 or 60 Hz  
 720p (SMPTE 296M -1,2,3) 50, 59.94 or 60 Hz  
 1080p (SMPTE 274M -9,10,11) 23.98, 24, 25 Hz  
 1080sF (RP211 -14,15,16) 23.98, 24, 25 Hz  
 1080p (SMPTE 424M, 425M), 50, 59.94, 60, Level A  
 525i, 625i (SMPTE 259M)

### Serial Digital Output

Number	Two, BNC
Type	Follows Input
Impedance	75 Ω
Return Loss	>15 dB to 1.485 GHz >10 dB to 2.97 GHz
Output DC	None (AC coupled)

### Optical Output (BE83-F Only)

Number	One, LC/UPC
Type	Follows Input
Wavelength	1310 nm (non-CWDM) Wavelengths 170 nm –1610 nm at 20 nm CWDM spacing available. Call factory for price and specify part number BE83-F-SP.
Power	-7 dBm
Max Cable Length	20 km (For greater distances, or higher power and larger loss budgets, please contact the factory)
Fiber Type	Single Mode Multi-mode compatible with attenuation at transmit end

### General Specifications

Size	5.625" W x 0.8" H x 5.5" D (143 mm x 20 mm x 140 mm) including connectors
Power	12 volts, 5 watts
Temperature Range	0 to 40° C ambient
Relative Humidity	0 to 95° non-condensing



## Glossary

### AES/EBU

The digital audio standard defined as a joint effort of the Audio Engineering Society and the European Broadcast Union. AES/EBU or AES3 describes a serial bitstream that carries two audio channels, thus an AES stream is a stereo pair. The AES/EBU standard covers a wide range of sample rates and quantizations (bit depths). In television systems, these will generally be 48 KHz and either 20 or 24 bits.

### AFD

Active Format Description is a method to carry information regarding the aspect ratio of the video content. The specification of AFD was standardized by SMPTE in 2007 and is now beginning to appear in the marketplace. AFD can be included in both SD and HD SDI transport systems. There is no legacy analog implementation. (See WSS).

### ASI

A commonly used transport method for MPEG video streams, ASI or Asynchronous Serial Interface, operates at the same 270 Mb/s data rate as SD SDI. This makes it easy to carry an ASI stream through existing digital television infrastructure. Known more formally as DVB-ASI, this transport mechanism can be used to carry multiple program channels.

### Aspect Ratio

The ratio of the vertical and horizontal measurements of an image. 4:3 is the aspect ratio for standard definition video formats and television and 16:9 for high definition. Converting formats of unequal ratios is done by letterboxing (horizontal bars) or pillar boxing (vertical pillars) in order to keep the original format's aspect ratio.

### Bandwidth

Strictly speaking, this refers to the range of frequencies (i.e. the width of the band of frequency) used by a signal, or carried by a transmission channel. Generally, wider bandwidth will carry and reproduce a signal with greater fidelity and accuracy.

### Beta

Sony Beta SP video tape machines use an analog component format that is similar to SMPTE, but differs in the amplitude of the color difference signals. It may also carry setup on the luminance channel.

### Bit

A binary digit, or bit, is the smallest amount of information that can be stored or transmitted digitally by electrical, optical, magnetic, or other means. A single bit can take on one of two states: On/Off, Low/High, Asserted/ Deasserted, etc. It is represented numerically by the numerals 1 (one) and 0 (zero). A byte, containing 8 bits, can represent 256 different states. The binary number 11010111, for example, has the value of 215 in our base 10 numbering system. When a value is carried digitally, each additional bit of resolution will double the number of different states that can be represented. Systems

that operate with a greater number of bits of resolution, or quantization, will be able to capture a signal with more detail or fidelity. Thus, a video digitizer with 12 bits of resolution will capture 4 times as much detail as one with 10 bits.

## Blanking

The Horizontal and Vertical blanking intervals of a television signal refer to the time periods between lines and between fields. No picture information is transmitted during these times, which are required in CRT displays to allow the electron beam to be repositioned for the start of the next line or field. They are also used to carry synchronizing pulses which are used in transmission and recovery of the image. Although some of these needs are disappearing, the intervals themselves are retained for compatibility purposes. They have turned out to be very useful for the transmission of additional content, such as teletext and embedded audio.

## CAV

Component Analog Video. This is a convenient shorthand form, but it is subject to confusion. It is sometimes used to mean ONLY color difference component formats (SMPTE or Beta), and other times to include RGB format. In any case, a CAV signal will always require 3 connectors – either Y/R-Y/B-Y, or R/G/B.

## Checkfield

A Checkfield signal is a special test signal that stresses particular aspects of serial digital transmission. The performance of the Phase Locked-Loops (PLLs) in an SDI receiver must be able to tolerate long runs of 0's and 1's. Under normal conditions, only very short runs of these are produced due to a scrambling algorithm that is used. The Checkfield, also referred to as the Pathological test signal, will “undo” the scrambling and cause extremely long runs to occur. This test signal is very useful for testing transmission paths.

## Chroma

The color or chroma content of a signal, consisting of the hue and saturation of the image. See also Color Difference.

## Component

In a component video system, the totality of the image is carried by three separate but related components. This method provides the best image fidelity with the fewest artifacts, but it requires three independent transmission paths (cables). The commonly used component formats are Luminance and Color Difference (Y/Pr/Pb), and RGB. It was far too unwieldy in the early days of color television to even consider component transmission.

## Composite

Composite television dates back to the early days of color transmission. This scheme encodes the color difference information onto a color subcarrier. The instantaneous phase of the subcarrier is the color's hue, and the amplitude is the color's saturation or intensity. This subcarrier is then added onto the existing luminance video signal. This trick works because the subcarrier is set at a high enough frequency to leave spectrum for the luminance information. But it is not a seamless matter to pull the signal apart again at the destination in order to display it or process it. The resultant artifacts of

dot crawl (also referred to as chroma crawl) are only the most obvious result. Composite television is the most commonly used format throughout the world, either as PAL or NTSC. It is also referred to as Encoded video.

### **Color Difference**

Color Difference systems take advantage of the details of human vision. We have more acuity in our black and white vision than we do in color. This means that we need only the luminance information to be carried at full bandwidth, we can scrimp on the color channels. In order to do this, RGB information is converted to carry all of the luminance (Y is the black and white of the scene) in a single channel. The other two channels are used to carry the “color difference”. Noted as B-Y and R-Y, these two signals describe how a particular pixel “differs” from being purely black and white. These channels typically have only half the bandwidth of the luminance.

### **Decibel (dB)**

The decibel is a unit of measure used to express the ratio in the amplitude or power of two signals. A difference of 20 dB corresponds to a 10:1 ratio between two signals, 6 dB is approximately a 2:1 ratio. Decibels add while the ratios multiply, so 26 dB is a 20:1 ratio, and 14 dB is a 5:1 ratio. There are several special cases of the dB scale, where the reference is implied. Thus, dBm refers to power relative to 1 milliwatt, and dBu refers to voltage relative to .775V RMS. The original unit of measure was the Bel (10 times bigger), named after Alexander Graham Bell.

### **dBFS**

In Digital Audio systems, the largest numerical value that can be represented is referred to as Full Scale. No values or audio levels greater than FS can be reproduced because they would be clipped. The nominal operating point (roughly corresponding to 0 VU) must be set below FS in order to have headroom for audio peaks. This operating point is described relative to FS, so a digital reference level of -20 dBFS has 20 dB of headroom before hitting the FS clipping point.

### **DVI**

Digital Visual Interface. DVI-I (integrated) provides both digital and analog connectivity. The larger group of pins on the connector are digital while the four pins on the right are analog.

### **EDH**

Error Detection and Handling is a method to verify proper reception of an SDI or HD-SDI signal at the destination. The originating device inserts a data packet in the vertical interval of the SDI signal and every line of the HD signal which contains a checksum of the entire video frame. This checksum is formed by adding up the numerical values of all of the samples in the frame, using a complex formula. At the destination this same formula is applied to the incoming video and the resulting value is compared to the one included in the transmission. If they match, then the content has all arrived with no errors. If they don't, then an error has occurred.

### **Embedded Audio**

Digital Audio can be carried along in the same bitstream as an SDI or HD-SDI signal by taking advantage of the gaps in the transmission which correspond to the horizontal and vertical intervals of the television waveform. This technique can be very cost effective in transmission and routing, but

can also add complexity to signal handling issues because the audio content can no longer be treated independently of the video.

### **Eye Pattern**

To analyze a digital bitstream, the signal can be displayed visually on an oscilloscope by triggering the horizontal timebase with a clock extracted from the stream. Since the bit positions in the stream form a very regular cadence, the resulting display will look like an eye – an oval with slightly pointed left and right ends. It is easy to see from this display if the eye is “open”, with a large central area that is free of negative or positive transitions, or “closed” where those transitions are encroaching toward the center. In the first case, the open eye indicates that recovery of data from the stream can be made reliably and with few errors. But in the closed case data will be difficult to extract and bit errors will occur. Generally it is jitter in the signal that is the enemy of the eye.

### **Frame Sync**

A Frame Synchronizer is used to synchronize the timing of a video signal to coincide with a timing reference (usually a color black signal that is distributed throughout a facility). The synchronizer accomplishes this by writing the incoming video into a frame buffer memory under the timing direction of the sync information contained in that video. Simultaneously the memory is being read back by a timing system that is genlocked to a house reference. As a result, the timing or alignment of the video frame can be adjusted so that the scan of the upper left corner of the image is happening simultaneously on all sources. This is a requirement for both analog and digital systems in order to perform video effects or switch glitch-free in a router. Frame synchronization can only be performed within a single television line standard. A synchronizer will not convert an NTSC signal to a PAL signal, it takes a standards converter to do that.

### **Frequency Response**

A measurement of the accuracy of a system to carry or reproduce a range of signal frequencies. Similar to Bandwidth.

### **H.264**

The latest salvo in the compression wars is H.264 which is also known as MPEG-4 Part 10. MPEG-4 promises good results at just half the bit rate required by MPEG-2.

### **HD**

High Definition. This two letter acronym has certainly become very popular. Here we thought it was all about the pictures – and the radio industry stole it.

### **HDCP**

HDCP (High-bandwidth Digital Content Protection) is a content encryption system for HDMI. It is meant to prevent copyright content from being copied. Protected content, like a movie on a Blu-Ray disc is encrypted by its creator. Devices that want to display the protected content, like a television, must have an authorized key in order to decode the signal and display it. The entity that controls the HDCP standard strictly limits the kinds of devices that are allowed decryption keys. Devices that decrypt the content and provide an unencrypted copy are not allowed.

## HDMI

The High Definition Multimedia Interface comes to us from the consumer marketplace where it is becoming the de facto standard for the digital interconnect of display devices to audio and video sources. It is an uncompressed, all-digital interface that transmits digital video and eight channels of digital audio. HDMI is a bit serial interface that carries the video content in digital component form over multiple twisted-pairs. HDMI is closely related to the DVI interface for desktop computers and their displays.

## IEC

The International Electrotechnical Commission provides a wide range of worldwide standards. They have provided standardization of the AC power connection to products by means of an IEC line cord. The connection point uses three flat contact blades in a triangular arrangement, set in a rectangular connector. The IEC specification does not dictate line voltage or frequency. Therefore, the user must take care to verify that a device either has a universal input (capable of 90 to 230 volts, either 50 or 60 Hz), or that a line voltage switch, if present, is set correctly.

## Interlace

Human vision can be fooled to see motion by presenting a series of images, each with a small change relative to the previous image. In order to eliminate the flicker, our eyes need to see more than 30 images per second. This is accomplished in television systems by dividing the lines that make up each video frame (which run at 25 or 30 frames per second) into two fields. All of the odd-numbered lines are transmitted in the first field, the even-numbered lines are in the second field. In this way, the repetition rate is 50 or 60 Hz, without using more bandwidth. This trick has worked well for years, but it introduces other temporal artifacts. Motion pictures use a slightly different technique to raise the repetition rate from the original 24 frames that make up each second of film—they just project each one twice.

## IRE

Video level is measured on the IRE scale, where 0 IRE is black, and 100 IRE is full white. The actual voltages that these levels correspond to can vary between formats.

## ITU-R 601

This is the principal standard for standard definition component digital video. It defines the luminance and color difference coding system that is also referred to as 4:2:2. The standard applies to both PAL and NTSC derived signals. They both will result in an image that contains 720 pixels horizontally, with 486 vertical pixels in NTSC, and 576 vertically in PAL. Both systems use a sample clock rate of 27 MHz, and are serialized at 270 Mb/s.

## Jitter

Serial digital signals (either video or audio) are subject to the effects of jitter. This refers to the instantaneous error that can occur from one bit to the next in the exact position of each digital transition. Although the signal may be at the correct frequency on average, in the interim it varies. Some bits come slightly early, others come slightly late. The measurement of this jitter is given either as the amount of time uncertainty or as the fraction of a bit width. For 270 Mb/s SD video, the allowable jitter is 740 picoseconds, or 0.2 UI (Unit Interval – one bit width). For 1.485 Gb/s HD, the same 0.2UI spec corresponds to just 135 pico seconds.

## **Luminance**

The “black & white” content of the image. Human vision had more acuity in luminance, so television systems generally devote more bandwidth to the luminance content. In component systems, the luminance is referred to as Y.

## **MPEG**

The Moving Picture Experts Group is an industry group that develops standards for the compression of moving pictures for television. Their work is an on-going effort. The understanding of image processing and information theory is constantly expanding. And the raw bandwidth of both the hardware and software used for this work is ever increasing. Accordingly, the compression methods available today are far superior to the algorithms that originally made the real-time compression and decompression of television possible. Today, there are many variations of these techniques, and the term MPEG has to some extent become a broad generic label.

## **Metadata**

This word comes from the Greek, meta means ‘beyond’ or ‘after’. When used as a prefix to ‘data’, it can be thought of as ‘data about the data’. In other words, the metadata in a data stream tells you about that data – but it is not the data itself. In the television industry, this word is sometimes used correctly when, for example, we label as metadata the timecode which accompanies a video signal. That timecode tells you something about the video, i.e. when it was shot, but the timecode in and of itself is of no interest. But in our industry’s usual slovenly way in matters linguistic, the term metadata has also come to be used to describe data that is associated with the primary video in a datastream. So embedded audio will (incorrectly) be called metadata when it tells us nothing at all about the pictures. Oh well.

## **Multi-mode**

Multi-mode fibers have a larger diameter core than single mode fibers (either 50 or 62.5 microns compared to 9 microns), and a correspondingly larger aperture. It is much easier to couple light energy into a multi-mode fiber, but internal reflections will cause multiple “modes” of the signal to propagate down the fiber. This will degrade the ability of the fiber to be used over long distances. See also Single Mode.

## **NTSC**

The color television encoding system used in North America was originally defined by the National Television Standards Committee. This American standard has also been adopted by Canada, Mexico, Japan, Korea, and Taiwan. (This standard is referred to disparagingly as Never Twice Same Color.)

## **Optical**

An optical interface between two devices carries data by modulating a light source. This light source is typically a laser or laser diode (similar to an LED) which is turned on and off at the bitrate of the datastream. The light is carried from one device to another through a glass fiber. The fiber’s core acts as a waveguide or lightpipe to carry the light energy from one end to another. Optical transmission has two very significant advantages over metallic copper cables. Firstly, it does not require that the two endpoint devices have any electrical connection to each other. This can be very advantageous in large facilities where problems with ground loops appear. And secondly, and most importantly, an

optical interface can carry a signal for many kilometers or miles without any degradation or loss in the recovered signal. Copper is barely useful at distances of just 1000 feet.

### **Oversampling**

A technique to perform digital sampling at a multiple of the required sample rate. This has the advantage of raising the Nyquist Rate (the maximum frequency which can be reproduced by a given sample rate) much higher than the desired passband. This allows more easily realized anti-aliasing filters.

### **PAL**

During the early days of color television in North America, European broadcasters developed a competing system called Phase Alternation by Line. This slightly more complex system is better able to withstand the differential gain and phase errors that appear in amplifiers and transmission systems. Engineers at the BBC claim that it stands for Perfection At Last.

**Pathological Test Pattern** – see Checkfield

### **Progressive**

An image scanning technique which progresses through all of the lines in a frame in a single pass. Computer monitors all use progressive displays. This contrasts to the interlace technique common to television systems.

### **Return Loss**

An idealized input or output circuit will exactly match its desired impedance (generally 75 ohms) as a purely resistive element, with no reactive (capacitive or inductive) elements. In the real world, we can only approach the ideal. So, our real inputs and outputs will have some capacitance and inductance. This will create impedance matching errors, especially at higher frequencies. The Return Loss of an input or output measures how much energy is returned (reflected back due to the impedance mismatch). For digital circuits, a return loss of 15 dB is typical. This means that the energy returned is 15 dB less than the original signal. In analog circuits, a 40 dB figure is expected.

### **RGB**

RGB systems carry the totality of the picture information as independent Red, Green, and Blue signals. Television is an additive color system, where all three components add to produce white. Because the luminance (or detail) information is carried partially in each of the RGB channels, all three must be carried at full bandwidth in order to faithfully reproduce an image.

### **Sch Phase**

Used in composite systems, Sch Phase measures the relative phase between the leading edge of sync on line 1 of field 1 and a continuous subcarrier sinewave. Due to the arithmetic details of both PAL and NTSC, this relationship is not the same at the beginning of each frame. In PAL, the pattern repeats every 4 frames (8 fields) which is also known as the Bruch Blanking sequence. In NTSC, the repeat is every 2 frames (4 fields). This creates enormous headaches in editing systems and the system timing of analog composite facilities.

## Setup

In the NTSC Analog Composite standard, the term Setup refers to the addition of an artificial offset or pedestal to the luminance content. This places the Black Level of the analog signal 54 mV (7.5 IRE) positive with respect to ground. The use of Setup is a legacy from the early development of television receivers in the vacuum tube era. This positive offset helped to prevent the horizontal retrace of the electron beam from being visible on the CRT, even if Brightness and Contrast were mis-adjusted. While the use of Setup did help to prevent retrace artifacts, it did so at the expense of dynamic range (contrast) in the signal because the White Level of the signal was not changed.

Setup is optional in NTSC systems, but is never used in PAL systems (see 'Perfection' characteristic of PAL). This legacy of Setup continues to persist in North American NTSC systems, while it has been abandoned in Japan.

In the digital component world (SD and HD SDI) there is obviously no need for, and certainly every reason to avoid, Setup. In order for the interfaces between analog and digital systems to operate as transparently as possible, Setup must be carefully accounted for in conversion products. When performing analog to digital conversion, Setup (if present) must be removed and the signal range gained up to account for the 7.5% reduction in dynamic range. And when a digital signal is converted back to analog form, Setup (if desired on the output) must be created by reducing the dynamic range by 7.5% and adding the 54 mV positive offset. Unfortunately, there is no truly foolproof algorithm to detect the presence of Setup automatically, so it's definitely a case of installer beware.

## SDI

Serial Digital Interface. This term refers to inputs and outputs of devices that support serial digital component video. This could refer to standard definition at 270 Mb/s, HD SDI or High Definition Serial Digital video at 1.485 Gb/s, or to the newer 3G standard of High Definition video at 2.97 Gb/s.

## SMPTE

The Society of Motion Picture and Television Engineers is a professional organization which has done tremendous work in setting standards for both the film and television industries. The term "SMPTE" is also shorthand for one particular component video format - luminance and color difference.

## Single Mode

A Single mode (or mono mode) optical fiber carries an optical signal on a very small diameter (9 micron) core surrounded with cladding. The small diameter means that no internally reflected lightwaves will be propagated. Thus only the original "mode" of the signal passes down the fiber. A single mode fiber used in an optical SDI system can carry a signal for up to 20 kilometers. Single mode fibers require particular care in their installation due to the extremely small optical aperture that they present at splice and connection points. See also Multi-mode.

## TBC

A Time Base Corrector is a system to reduce the Time Base Error in a signal to acceptable levels. It accomplishes this by using a FIFO (First In, First Out) memory. The incoming video is written into the memory using its own jittery timing. This operation is closely associated with the actual digitization of the analog signal because the varying position of the sync timing must be mimicked by the sampling



function of the analog to digital converter. A second timing system, genlocked to a stable reference, is used to read the video back out of the memory. The memory acts as a dynamically adjusting delay to smooth out the imperfections in the original signal's timing. Very often a TBC will also function as a Frame Synchronizer. See also Frame Sync.

### **Time Base Error**

Time base error is present when there is excessive jitter or uncertainty in the line to line output timing of a video signal. This is commonly associated with playback from video tape recorders, and is particularly severe with consumer type heterodyne systems like VHS. Time base error will render a signal unusable for broadcast or editing purposes.

### **Timecode**

Timecode, a method to uniquely identify and label every frame in a video stream, has become one of the most recognized standards ever developed by SMPTE. It uses a 24 hour clock, consisting of hours, minutes, seconds, and television frames. Originally recorded on a spare audio track, this 2400 baud signal was a significant contributor to the development of video tape editing. We now refer to this as LTC or Longitudinal Time Code because it was carried along the edge of the tape. This allowed it to be recovered in rewind and fast forward when the picture itself could not. Timecode continues to be useful today and is carried in the vertical interval as VITC, and as a digital packet as DVITC. Timecode is the true metadata.

### **Tri-Level Sync**

For many, many years, television systems used composite black as a genlock reference source. This was a natural evolution from analog systems to digital implementations. With the advent of High Definition television, with even higher data rates and tighter jitter requirements, problems with this legacy genlock signal surfaced. Further, a reference signal with a 50 or 60 Hz frame rate was useless with 24 Hz HD systems running at film rates. Today we can think of composite black as a bi-level sync signal – it has two levels, one at sync tip and one at blanking. For HD systems, Tri-Level Sync, which has the same blanking level (at ground) of bi-level sync, but the sync pulse now has both a negative and a positive element. This keeps the signal symmetrically balanced so that its DC content is zero. And it also means that the timing pickoff point is now at the point where the signal crosses blanking and is no longer subject to variation with amplitude. This makes Tri-Level Sync a much more robust signal and one which can be delivered with less jitter.

### **USB**

The Universal Serial Bus, developed in the computer industry to replace the previously ubiquitous RS-232 serial interface, now appears in many different forms and with many different uses. It actually forms a small local area network, allowing multiple devices to coexist on a single bus where they can be individually addressed and accessed.

### **VGA**

Video Graphics Array. Traditional 15-pin, analog interface between a PC and monitor.

## **Word Clock**

Use of Word Clock to genlock digital audio devices developed in the audio recording industry. Early digital audio products were interconnected with a massive parallel connector carrying a twisted pair for every bit in the digital audio word. A clock signal, which is a square wave at the audio sampling frequency, is carried on a 75 ohm coaxial cable. Early systems would daisychain this 44.1 or 48 kilohertz clock from one device to another with coax cable and Tee connectors. On the rising edge of this Word Clock these twisted pairs would carry the left channel, while on the falling edge, they would carry the right channel. In most television systems using digital audio, the audio sample clock frequency (and hence the 'genlock' between the audio and video worlds) is derived from the video genlock signal. But products that are purely audio, with no video reference capability, may still require Word Clock.

## **WSS**

Wide Screen Signaling is used in the PAL/625 video standards, both in analog and digital form, to convey information about the aspect ratio and format of the transmitted signal. Carried in the vertical interval, much like closed captioning, it can be used to signal a television receiver to adjust its vertical or horizontal sizing to reflect incoming material. Although an NTSC specification for WSS exists, it never achieved any traction in the marketplace.

## **YUV**

Strictly speaking, YUV does not apply to component video. The letters refer to the Luminance (Y), and the U and V encoding axes using in the PAL composite system. Since the U axis is very close to the B-Y axis, and the V axis is very close to the R-Y axis, YUV is often used as a sort of shorthand for the more long-winded "Y/R-Y/B-Y".

## **Y/Cr/Cb**

In digital component video, the luminance component is Y, and the two color difference signals are Cr (R-Y) and Cb (B-Y).

## **Y/Pr/Pb**

In analog component video, the image is carried in three components. The luminance is Y, the R-Y color difference signal is Pr, and the B-Y color difference signal is Pb.