



BrightEye™ 70

HD/SD AES Embedder/Disembedder User Guide

ENSEMBLE

D E S I G N S

Revision 3.1 SW v1.0.0

This user guide provides detailed information for using the **BrightEye™70** HD/SD AES Embedder/Disembedder unit.

The information is organized into the following sections:

- Product Overview
- Functional Description
- Applications
- Rear Connectors
- Operation
 - Front Panel Controls and Indicators
 - Using The BrightEye Control Application
- Warranty and Factory Service
- Specifications
- Glossary

PRODUCT OVERVIEW

The BrightEye 70 is a dual rate, eight channel audio embedder or disembedder for 1.5 Gb/s high definition video signals or for 270 Mb/s standard definition signals. Four AES ports automatically configure for inputs or outputs when the module is configured for Mux or Demux.

Selection of Mux or Demux mode, AES group selection, VU status, and gain adjustment can be monitored and adjusted from the front panel. More advanced functionality is available via the BrightEye Control application.

The BrightEye 70 includes an eight channel audio mixer with channel swap and shuffle capability that allows you to completely rearrange and remix audio channels. It provides precise control over audio level, up to 2 dB of gain to compensate for low level sources. All audio processing is performed at full 24 bit resolution by a digital signal processor (DSP).

Delay is adjustable up to one second. The Data mode operation allows embedding or disembedding of Dolby E or AC3 signals.

A glossary of commonly used video terms is provided at the end of this manual.

FUNCTIONAL DESCRIPTION

When configured as a multiplexer as shown in the functional block diagram below, the BrightEye 70 has one serial digital video input and four AES inputs. The four AES streams are sample rate converted (allowing the use of asynchronous audio) then processed in the input selector and mixer/shuffler. The selected groups are then embedded into the video stream. The output of the module is a digital stream that contains the original video signal and four audio pairs.

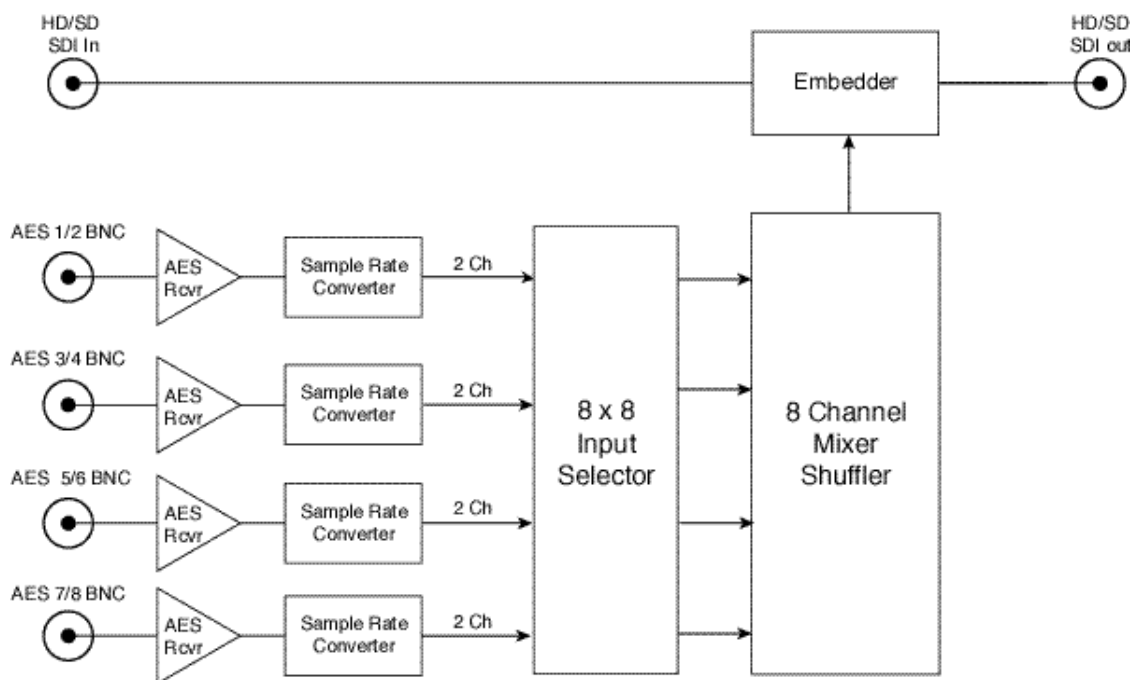

BrightEye 70 Multiplexer (Embedder) Mode Functional Block Diagram

When configured as a demultiplexer as shown in the block diagram below, audio signals present in the incoming video signal are extracted, processed as desired, and delivered as standard AES digital audio streams.

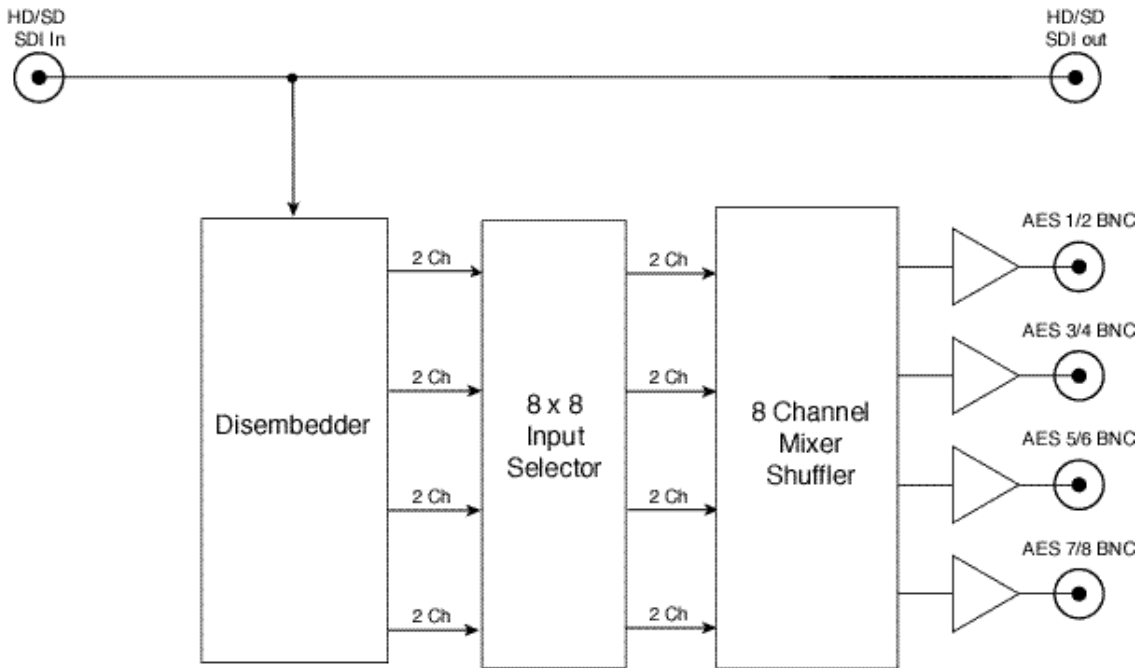

BrightEye 70 Demultiplexer (Disembedder) Mode Functional Block Diagram

APPLICATIONS

The BrightEye 70 is a highly versatile embedder/disembedder. Because of this versatility and its compact form factor, the BrightEye 70 is very useful in applications where size and versatility are important. Examples of possible BrightEye 70 multiplex and demultiplex applications are given below.

Embedder (Mux) And Disembedder (Demux)

In this application, BrightEye 70 can be used to multiplex video and audio together to feed a video server. The output from the video server can then be fed to another BrightEye 70 where the audio can then be demultiplexed for another application.

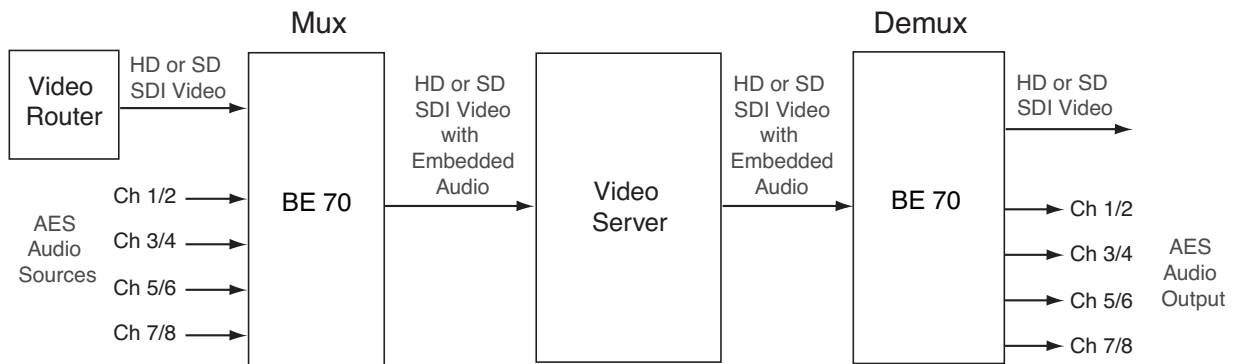

BrightEye 70 Multiplex and Demultiplex Application

Embedder (Mux)

In this application, serial digital audio from a router are combined into a single SDI output with embedded digital audio.

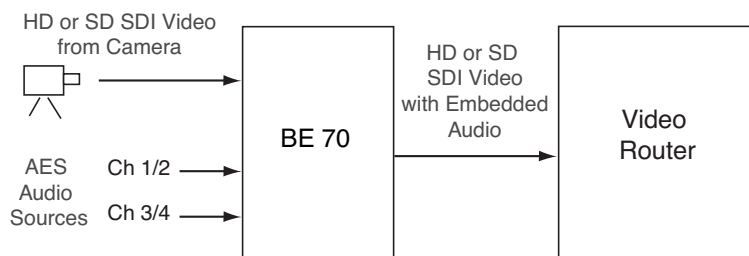

BrightEye 70 Multiplex Application

REAR CONNECTORS

All connections to the BrightEye 70 are made on the rear of the unit. Refer to the illustration below.



BrightEye 70 Rear Connectors

Power Connection

Connect a modular power supply to the 12 volt DC power input connection on the far left of the unit. Use the locking ring to secure it.

USB Connector

The USB connector is used to provide more comprehensive control, diagnostics, and upgrades to the unit from a PC or Mac. Use the BrightEye Control application included on CD-ROM to make adjustments as described in the **OPERATION** section of this user guide.

HD/SD SDI Out

This output is a digital stream that contains the original video signal and four AES pairs.

When the module is configured as a multiplexer, the AES BNCs are configured as inputs. This external AES audio is multiplexed into the SDI output as desired.

When the module is configured as a demultiplexer, this output contains the original video and the original embedded audio. The audio signals present in this incoming video signal are extracted and delivered as outputs on the AES BNCs.

AES 1/2, AES 3/4, AES 5/6, and AES 7/8

The **AES 1/2**, **AES 3/4**, **AES 5/6**, and **AES 7/8** BNCs are either inputs or outputs depending on how the module is configured (Mux or Demux). Each connector inputs or outputs an AES stream (each stream containing 2 channels.)

When the module is configured as a multiplexer (Mux), the AES BNCs are inputs.

When configured as a demultiplexer (Demux), the AES BNCs are outputs.

HD/SD SDI In

This BNC input accepts an HD or SD SDI serial digital video signal with or without embedded audio. When the module is configured as a demultiplexer, embedded audio present on this input stream can be extracted, processed on the module, then output from the module on the AES audio BNCs as outputs.

When configured as a multiplexer, external AES audio can be inserted into the SDI input stream or replace existing embedded audio.

OPERATION

Control and operation of the BrightEye 70 is performed from the front panel or with the BrightEye Control application.

NOTE: Some control settings are only available with the BrightEye Control application. These parameters cannot be monitored or controlled with the front panel.

Front Panel Controls and Indicators

The front panel of the converter, shown in the figure below, provides status indicators and control over module setup.



BrightEye 70 Front Panel

Status Indicators

The following status indicators are provided on the front panel:

In

Illuminate green when a valid input is present on the **SDI In** connector.

Mode

The currently selected mode (**Mux** or **Demux**) is illuminated green.

Group

The AES group (**1**, **2**, **3**, or **4**) currently targeted for embedding or disembedding (depending on module configuration) illuminates green when the selected group contains audio, and illuminates red when the selected group does not contain audio.

Gain

These controls allow for quick adjustment of Gain level for the four channel pairs. Gain adjustment is done in conjunction with the VU indicators. For independent channel adjustment, and other controls, use the BrightEye Control application.

VU

VU output level and the status of the **Gain** adjustment for each of these channel pairs is indicated by the state the **VU** and **Gain** indicators for each of the channel pairs. The **VU** indicator illuminates red when the audio level exceeds the headroom level set by the user (with the **Peak Indicator** control in BrightEye PC or Mac).

Additionally, the **VU** indicator illuminates orange when the output is above 0 VU, illuminates green when the output is above -20 VU, and doesn't illuminate when the output is below -20 VU. The **Gain** indicator illuminates red when the gain level has been adjusted off from unity by the user. The 0 VU point corresponds in the digital domain to the digital reference level (-18 or -20 dBFS.)

Pwr (Power)

Illuminates green when power is applied to the converter and the internal voltage regulator is functioning correctly.

ADJUSTING PARAMETERS FROM THE FRONT PANEL

Use the **Mode**, **Right Arrow**, and **Left Arrow** buttons to select and adjust parameters from the front panel.

Pressing the **Mode** button activates the front panel for editing and tabs between each section of editable parameters.

Pressing the **Right Arrow** or **Left Arrow** advances the selection within a given section of parameters, or increases (Right Arrow) or decreases (Left Arrow) the value of a selected parameter.

NOTE: *The LED of an edited parameter will blink for 15 seconds, after which time its value is stored in memory. If power is interrupted before this 15 second timeout period has elapsed, the edited state will not be saved.*

The controls and their indicators are described below:

Mode

This control selects the Mux behavior with the following choices:

Mux – Embed audio into the SDI signal, replacing the existing embedded content or cascading, augmenting the existing embedded content.

Demux – Disembed audio that is in the SDI signal.

Group Select

This control selects the AES group for embedding with the following choices:

- 1 – AES Group 1
- 2 – AES Group 2
- 3 – AES Group 3
- 4 – AES Group 4

Ch 1/2, Ch 3/4, Ch 5/6, and Ch 7/8 VU Indicators

These indicators provide information about the level of the analog outputs on these channels. More detailed indicators are available through the BrightEye Control application.

Ch 1/2, Ch 3/4, Ch 5/6, and Ch 7/8 Gain Adjustment Indicators

These controls allow for quick adjustment of Gain level for these two channel pairs. For independent channel adjustment, and other controls, use BrightEye PC or Mac.

USING THE BRIGHT EYE CONTROL APPLICATION

The BrightEye PC and BrightEye Mac applications included on CD-ROM are designed to allow you to configure and control the BrightEye 70 from a personal computer. Installation and instructions for using this software application are given in the PDF manual on disk.

If the BrightEye 70 is connected to a computer running this software, the following menus are available for controlling and monitoring the unit.

Config Menu

- **Input Pres** – indicates the presence of an HD or SD SDI input. One of the following values will be displayed: **720p/50**, **720p/59.94**, **720p/60**, **1080i/50**, **1080i/59.94**, **1080i/60**, **1080p/25**, **1080p/23.98**, **1080p/24**, **1080p/25**, **1080sF/25**, **1080sF/23.98**, **1080sF/24**, **SD 525**, **SD**, **625**, **No Input**, or **Unknown**.
- **Mode** – select the mode of the module as **Mux** or **Demux**.
- **Mux Mode** – select the type of multiplexing desired from **Mux Replace** or **Mux Cascade**,
- **Dig Ref Level** – selects the digital reference level. This pulldown lets you choose between: **-20 dBFS** or **-18 dBFS**.
- **Peak Indicator** – selects the amount of headroom to use in determining peak levels. This pulldown lets you chose between: **Clipping**, **2 dB Headroom**, **4 dB Headroom**, **6 dB Headroom**, **8 dB Headroom**, or **10 dB Headroom**.
- **Audio Delay** – allows you to set the amount of audio delay from 0 to 1000 msec.
- **Strip Audio** – when **On** all audio and EDH is stripped from the incoming stream. **Off**. leaves audio and EDH as it comes in on the input signal.

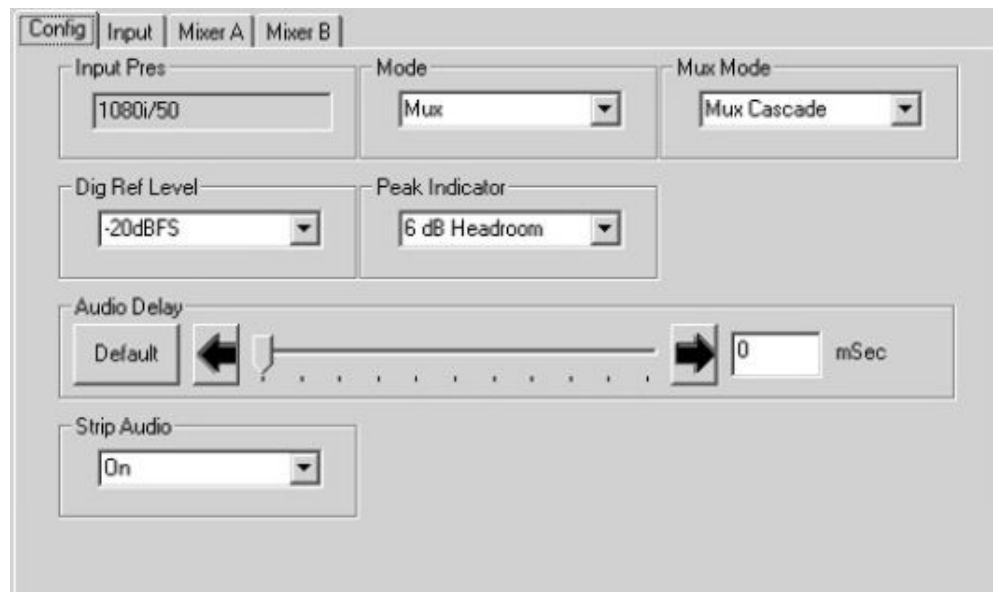

Input Menu

The appearance of the Input menu will depend on the mode of the module and the type of audio being used.

Multiplexer Mode

When the module is set for **Mux**, the Input menu provides the controls shown below:

- **Group A Status** – the status of the .audio selected in **Group A Select** will be displayed as **Off**, **No Audio Present**, **Group1 OK**, **Group 2 OK**, **Group 3 OK**, and **Group 4 OK**.
- **Group B Status** – the status of the .audio selected in **Group B Select** will be displayed as **Off**, **No Audio Present**, **Group1 OK**, **Group 2 OK**, **Group 3 OK**, and **Group 4 OK**.
- **Group A Select** – select the audio group to multiplex from **Group 1**, **Group 2**, **Group 3**, **Group 4**, or **Off** for either control.
- **Group B Select** – select the audio group to multiplex from **Group 1**, **Group 2**, **Group 3**, **Group 4**, or **Off** for either control.
- **AES 1/2, 3/4, 5/6, 7/8 Status** – for **Mux** mode, the AES inputs will report the audio type being input to the AES BNCs as **No Input**, **Sync Audio**, **Async Audio**, **Sync Data**, or **Async Data**

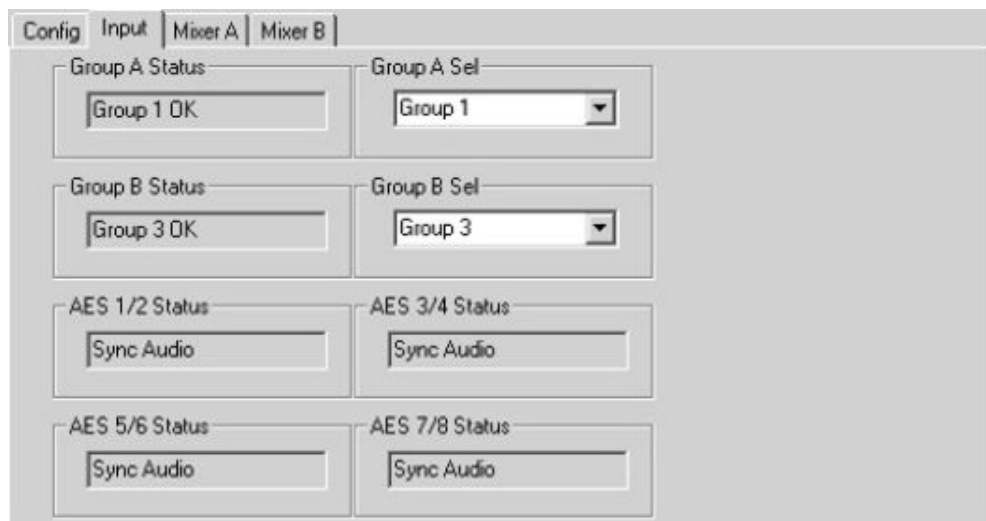

Demultiplexer Mode

When the module is set for **Demux**, the Input menu provides the controls shown below.

- **Group A Status** – the status of the .audio selected in **Group A Select** will be displayed as **Off**, **No Audio Present**, **Group1 OK**, **Group 2 OK**, **Group 3 OK**, and **Group 4 OK**.
- **Group B Status** – the status of the .audio selected in **Group B Select** will be displayed as **Off**, **No Audio Present**, **Group1 OK**, **Group 2 OK**, **Group 3 OK**, and **Group 4 OK**.
- **Group A Select** – select the audio group to demultiplex from **Group 1**, **Group 2**, **Group 3**, **Group 4**, or **Off** for either control.
- **Group B Select** – select the audio group to demultiplex from **Group 1**, **Group 2**, **Group 3**, **Group 4**, or **Off** for either control.
- **AES 1/2, 3/4, 5/6, 7/8 Status** – in **Demux** mode, the AES inputs will report the all AES audio status as being in **Output Mode**

The screenshot displays the 'Input' configuration window of the BrightEye 70 software. The window has a tabbed interface with 'Config', 'Input', 'Mixer A', and 'Mixer B' tabs. The 'Input' tab is active. The interface is organized into a grid of controls:

- Group A Status:** A text box displaying 'No Audio Present'.
- Group A Sel:** A dropdown menu currently set to 'Group 1'.
- Group B Status:** A text box displaying 'No Audio Present'.
- Group B Sel:** A dropdown menu currently set to 'Group 3'.
- AES 1/2 Status:** A text box displaying 'Output Mode'.
- AES 3/4 Status:** A text box displaying 'Output Mode'.
- AES 5/6 Status:** A text box displaying 'Output Mode'.
- AES 7/8 Status:** A text box displaying 'Output Mode'.

Mixer A Menu

- **Outputs 1-4** – provides peak/VU status, with the same methodology as the front panel VU indicators, but on a per-channel basis, rather than per-channel pair. **Peak/VU** indicators illuminate red when the audio level on that channel exceeds the headroom level set by the user (with the **Peak Indicator** control.) Additionally, the **VU** indicator illuminates orange when the output is above 0 VU, illuminates green when the output is above -20 VU, and doesn't illuminate when the output is below -20 VU.
- **Inputs Ch 1-4** – these controls provide mixing and output level control for AES channels 1 to 4 of the selected AES group. The text field at the top of the control indicates the amount of gain applied to the channel in dB. The gain level can be adjusted by moving the vertical slider control, or entering a desired level directly in the field (from -70 dB to +12 dB.) On the right-hand side of the control are **Out Bus Assign** buttons. These buttons control which analog output channel the AES channels are mapped to. It is possible to map an Input channel to anywhere from zero to eight output channels.

The **Tie** function is used for stereo operation where gain of a pair of channels is usually desired to be the same.

The **Default** button resets the gain to unity (0 dB).

The **Invert** button allows inversion of a channel to permit phase correction.

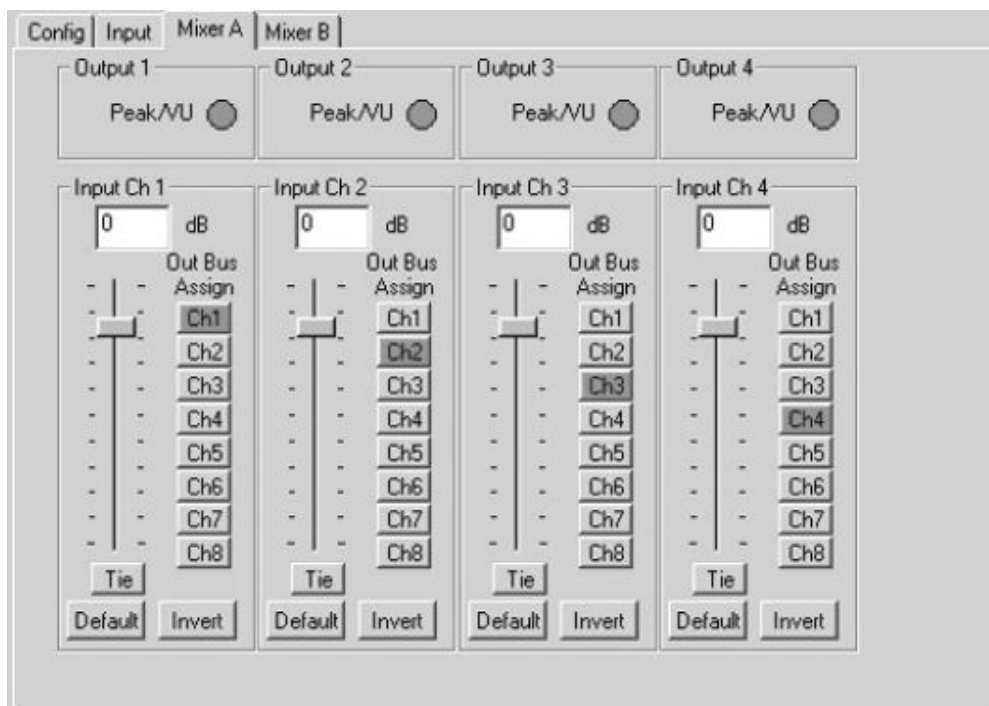

Mixer B Menu

- **Outputs 5-8** – provides peak/VU status, with the same methodology as the front panel VU indicators, but on a per-channel basis, rather than per-channel pair. **Peak/VU** indicators illuminate red when the audio level on that channel exceeds the headroom level set by the user (with the **Peak Indicator** control.) Additionally, the **VU** indicator illuminates orange when the output is above 0 VU, illuminates green when the output is above -20 VU, and doesn't illuminate when the output is below -20 VU.
- **Inputs Ch 5-8** – these controls provide mixing and output level control for AES channels 5 to 8 of the selected AES group. The text field at the top of the control indicates the amount of gain applied to the channel in dB. The gain level can be adjusted by moving the vertical slider control, or entering a desired level directly in the field (from -70 dB to +12 dB.) On the right-hand side of the control are **Out Bus Assign** buttons. These buttons control which analog output channel the AES channels are mapped to. It is possible to map an Input channel to anywhere from zero to eight output channels.

The **Tie** function is used for stereo operation where gain of a pair of channels is usually desired to be the same.

The **Default** button resets the gain to unity (0 dB).

The **Invert** button allows inversion of a channel to permit phase correction.

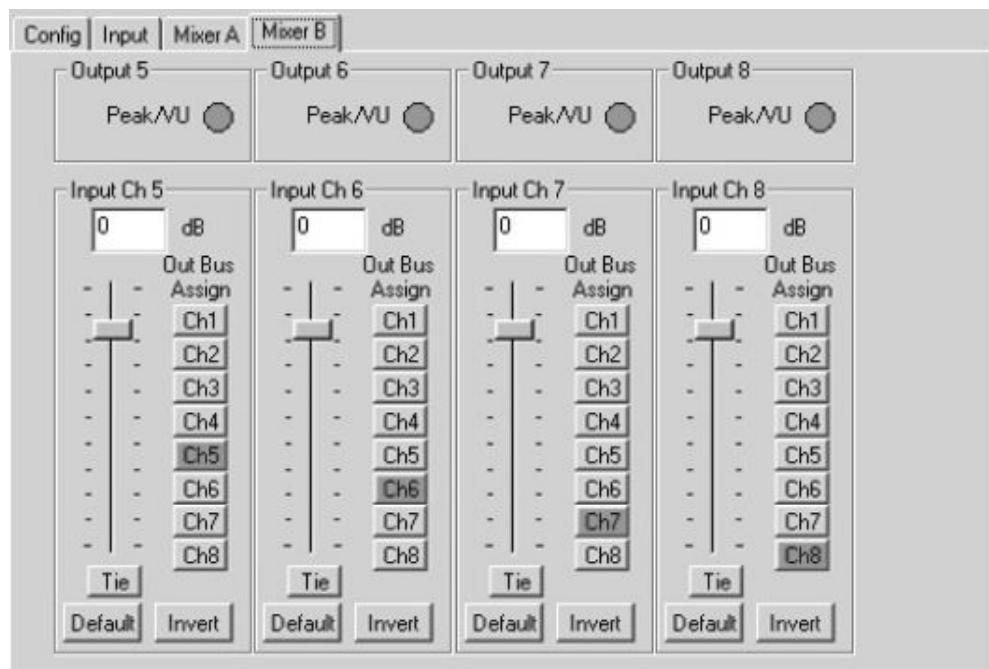

When an audio channel is a non-audio data signal, the controls on the **Mixer A** or **Mixer B** menu will be grayed out as shown in the example below..

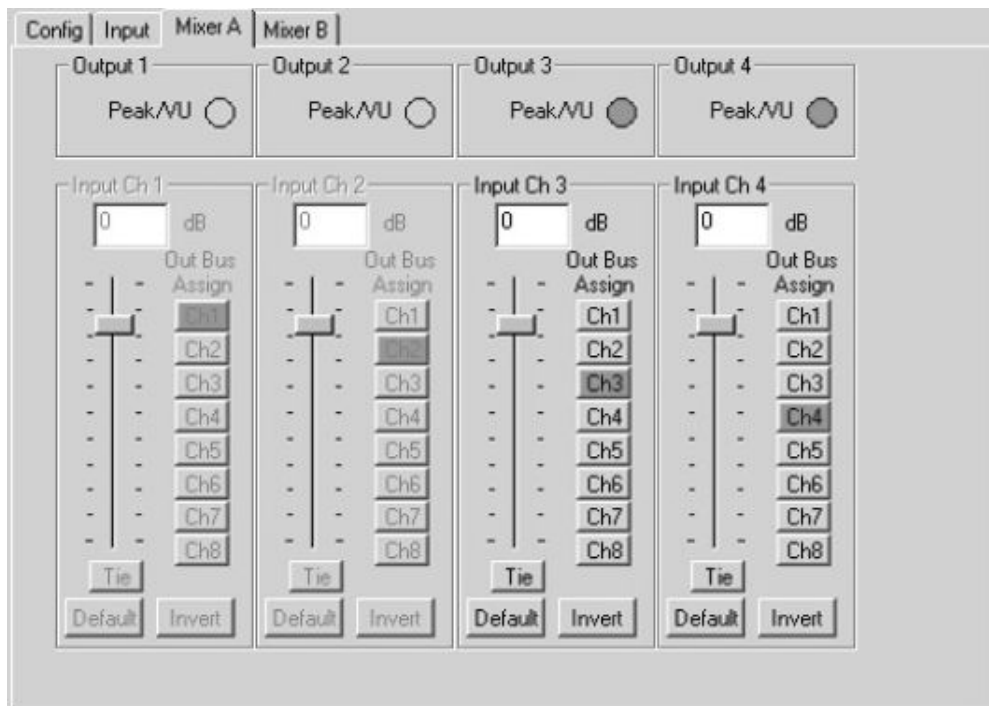

WARRANTY AND FACTORY SERVICE

Warranty

Ensemble Designs, Inc. warrants this product to be free from defect in material and workmanship for a period of 5 years from the date of delivery. During this 5 year warranty period, Ensemble Designs, Inc. will repair any defective units at Ensemble's expense if the unit should be determined to be defective after consultation with a factory technician.

This warranty is not transferable. Any implied warranties expire at the expiration date of this warranty.

This warranty does not cover a defect that has resulted from improper or unreasonable use or maintenance as determined by us. This warranty is void if there is any attempt to disassemble or adjust factory set presets without factory authorization.

Factory Service

If you require service (under warranty or not), please contact Ensemble Designs and ask for Customer Service before you return the unit. This will allow the service technician to provide any other suggestions for identifying the problem and recommend possible solutions.

You may also refer to the technical support section of the Ensemble web site for the latest information on your equipment at the URL below:

<http://www.ensembledesigns.com/support>

If you return equipment for repair, please get a Return Material Authorization Number (RMA) from the factory first.

Ship the product and a written description of the problem to:

Ensemble Designs, Inc.

Attention: Customer Service RMA #####

870 Gold Flat Rd.

Nevada City, CA 95959 USA

(530) 478-1830

Fax: (530) 478-1832

service@ensembledesigns.com

<http://www.ensembledesigns.com>

Be sure to put your RMA number on the outside of the box.

SPECIFICATIONS

Serial Digital Input:

Number:	One
Signal Type:	HD Serial Digital 1.485 Gb/s SMPTE 274M or 296M or SD Serial Digital 270Mb/s SMPTE 259M-C
Impedance:	75 Ω
Return Loss:	> 15 dB
Max. Cable Length:	100 meters for HD 300 meters for SD (Belden 1694A or equivalent)
HD Standards Supported:	1080i (SMPTE-274M-4,-5,-6) 50, 59.94 or 60 Hz 720p (SMPTE 296M-1,2,3) 59.94 or 60 Hz 1080p (SMPTE 274M-9,10,11) 23.98, 24, 25 Hz 1080sF (RP211-14,15,16) 23.98, 24, 25 Hz

Serial Digital Output:

Number:	One
Signal Type:	Follows input
Impedance:	75 Ω
Return Loss:	>15 dB
Output DC:	None (AC Coupled)

AES/EBU Digital Inputs:

Number:	Four (total of eight channels)
Type:	AES3id
Connectorization:	Coaxial, 75 Ω
Bit Depth:	20 and 24 bit
Sample Rate:	30 kHz to 100 kHz (sample rate converted internally to 48 kHz)
Reference Level:	-18 or -10 dBFS (selectable)
AC-3, Dolby E:	Supported when inputs are synchronous

Embedded Inputs:

Number:	Four AES Streams (from video input)
Type:	AES3id
Connectorization:	Coaxial, 75 Ω
Bit Depth:	24 bit
Sample Rate:	48 kHz (synchronous to video output)
Reference Level:	-18 or -10 dBFS (selectable)

AES/EBU Digital Outputs:

Number: Four (total of eight channels)
Type: AES3id
Connectorization: Coaxial, 75 Ω
Bit Depth: 24 bit
Sample Rate: 48 kHz
Reference Level: -18 or -10 dBFS (selectable)

Embedded Output (In SDI Outputs):

Group Assign: Replace or Cascade any two of four groups
Channels: Eight
Connectorization: Coaxial, 75 Ω
Bit Depth: 24 bit

General Specifications:

Size: 5.625" W x 0.8 " H x 5.5" D
(143 mm x 20 mm x 140 mm)
including connectors
Power: 12 volts, 7 watts
Power Consumption: 10 Watts
Temperature Range: 0 to 40 degrees C ambient
Relative Humidity: 0 to 95% noncondensing
Altitude: 0 to 10,000 ft.

Due to ongoing product development, all specifications are subject to change.

BRIGHTEYE POWER SUPPLY INFORMATION

Below is a list of power supplies and optional items that may have come with your BrightEye:

BEPS

BrightEye Individual Power Supply.

BEPS6

Spider Power Supply. This powers 6 single high BrightEyes or 3 double high BrightEyes (BrightEye 90 family).

BEPS6-RP

Redundant Power Supply for Spider.

BERKMT

BrightEye Rack Mount. This holds 6 single high BrightEyes or 3 double high BrightEyes (BrightEye 90 family) or a combination.

BEBP

BrightEye Blank Panel. Single high, for empty slots in Rack Mount.

BEAC

Analog Audio Breakout Cable.

GLOSSARY

This is a brief glossary of commonly used terms associated with this product.

AES/EBU

The digital audio standard defined as a joint effort of the Audio Engineering Society and the European Broadcast Union. AES/EBU or AES3 describes a serial bitstream that carries two audio channels, thus an AES stream is a stereo pair. The AES/EBU standard covers a wide range of sample rates and quantization (bit depths.) In television systems, these will generally be 48 kHz and either 20 or 24 bits.

Bandwidth

Strictly speaking, this refers to the range of frequencies (i.e. the width of the band of frequency) used by a signal, or carried by a transmission channel. Generally, wider bandwidth will carry and reproduce a signal with greater fidelity and accuracy.

Beta

Sony Beta SP video tape machines use an analog component format that is similar to SMPTE, but differs in the amplitude of the color difference signals. It may also carry setup on the luminance channel.

Blanking

The Horizontal and Vertical blanking intervals of a television signal refer to the time periods between lines and between fields. No picture information is transmitted during these times, which are required in CRT displays to allow the electron beam to be repositioned for the start of the next line or field. They are also used to carry synchronizing pulses which are used in transmission and recovery of the image. Although some of these needs are disappearing, the intervals themselves are retained for compatibility purposes. They have turned out to be very useful for the transmission of additional content, such as teletext and embedded audio.

CAV

Component Analog Video. This is a convenient shorthand form, but it is subject to confusion. It is sometimes used to mean ONLY color difference component formats (SMPTE or Beta), and other times to include RGB format. In any case, a CAV signal will always require 3 connectors – either Y/R-Y/B-Y, or R/G/B.

Checkfield

A Checkfield signal is a special test signal that stresses particular aspects of serial digital transmission. The performance of the Phase Locked-Loops (PLLs) in an SDI receiver must be able to tolerate long runs of 0's and 1's. Under normal conditions, only very short runs of these are produced due to a scrambling algorithm that is used. The Checkfield, also referred to as the Pathological, test signal, will “undo” the scrambling and cause extremely long runs to occur. This test signal is very useful for testing transmission paths.

Chroma

The color or chroma content of a signal, consisting of the hue and saturation of the image. See also Color Difference.

Component

In a component video system, the totality of the image is carried by three separate but related components. This method provides the best image fidelity with the fewest artifacts, but it requires three independent transmission paths (cables). The commonly used component formats are Luminance and Color Difference (Y/Pr/Pb), and RGB. It was far too unwieldy in the early days of color television to ever consider component transmission.

Composite

Composite television dates back to the early days of color transmission. This scheme encodes the color difference information onto a color subcarrier. The instantaneous phase of the subcarrier is the color's hue, and the amplitude is the color's saturation or intensity. This subcarrier is then added onto the existing luminance video signal. This trick works because the subcarrier is set at a high enough frequency to leave spectrum for the luminance information. But it is not a seamless matter to pull the signal apart again at the destination in order to display it or process it. The resultant artifacts of dot crawl (also referred to as chroma crawl) are only the most obvious result. Composite television is the most commonly used format throughout the world, either as PAL or NTSC. It is also referred to as Encoded video.

Color Difference

Color Difference systems take advantage of the details of human vision. We have more acuity in our black and white vision than we do in color. This means that we need only the luminance information to be carried at full bandwidth, we can scrimp on the color channels. In order to do this, RGB information is converted to carry all of the luminance (Y is the black and white of the scene) in a single channel. The other two channels are used to carry the "color difference". Noted as B-Y and R-Y, these two signals describe how a particular pixel "differs" from being purely black and white. These channels typically have only half the bandwidth of the luminance.

Decibel (dB)

The decibel is a unit of measure used to express the ratio in the amplitude or power of two signals. A difference of 20 dB corresponds to a 10:1 ratio between two signals, 6 dB is approximately a 2:1 ration. Decibels add while the ratios multiply, so 26 dB is a 20:1 ratio, and 14 dB is a 5:1 ratio. There are several special cases of the dB scale, where the reference is implied. Thus, dBm refers to power relative to 1 milliwatt, and dBu refers to voltage relative to .775V RMS. The original unit of measure was the Bel (10 times bigger), named after Alexander Graham Bell.

dBFS

In Digital Audio systems, the largest numerical value that can be represented is referred to as Full Scale. No values or audio levels greater than FS can be reproduced because they would be clipped. The nominal operating point (roughly corresponding to 0 VU) must be set below FS in order to have headroom for audio peaks. This operating point is described relative to FS, so a digital reference level of -20 dBFS has 20 dB of headroom before hitting the FS clipping point.

Component

In a component video system, the totality of the image is carried by three separate but related components. This method provides the best image fidelity with the fewest artifacts, but it requires three independent transmission paths (cables). The commonly used component formats are Luminance and Color Difference (Y/Pr/Pb), and RGB. It was far too unwieldy in the early days of color television to ever consider component transmission.

Composite

Composite television dates back to the early days of color transmission. This scheme encodes the color difference information onto a color subcarrier. The instantaneous phase of the subcarrier is the color's hue, and the amplitude is the color's saturation or intensity. This subcarrier is then added onto the existing luminance video signal. This trick works because the subcarrier is set at a high enough frequency to leave spectrum for the luminance information. But it is not a seamless matter to pull the signal apart again at the destination in order to display it or process it. The resultant artifacts of dot crawl (also referred to as chroma crawl) are only the most obvious result. Composite television is the most commonly used format throughout the world, either as PAL or NTSC. It is also referred to as Encoded video.

Color Difference

Color Difference systems take advantage of the details of human vision. We have more acuity in our black and white vision than we do in color. This means that we need only the luminance information to be carried at full bandwidth, we can scrimp on the color channels. In order to do this, RGB information is converted to carry all of the luminance (Y is the black and white of the scene) in a single channel. The other two channels are used to carry the "color difference". Noted as B-Y and R-Y, these two signals describe how a particular pixel "differs" from being purely black and white. These channels typically have only half the bandwidth of the luminance.

Decibel (dB)

The decibel is a unit of measure used to express the ratio in the amplitude or power of two signals. A difference of 20 dB corresponds to a 10:1 ratio between two signals, 6 dB is approximately a 2:1 ration. Decibels add while the ratios multiply, so 26 dB is a 20:1 ratio, and 14 dB is a 5:1 ratio. There are several special cases of the dB scale, where the reference is implied. Thus, dBm refers to power relative to 1 milliwatt, and dBu refers to voltage relative to .775V RMS. The original unit of measure was the Bel (10 times bigger), named after Alexander Graham Bell.

dBFS

In Digital Audio systems, the largest numerical value that can be represented is referred to as Full Scale. No values or audio levels greater than FS can be reproduced because they would be clipped. The nominal operating point (roughly corresponding to 0 VU) must be set below FS in order to have headroom for audio peaks. This operating point is described relative to FS, so a digital reference level of -20 dBFS has 20 dB of headroom before hitting the FS clipping point.

EDH

Error Detection and Handling is a method to verify proper reception of an SDI or HD-SDI signal at the destination. The originating device inserts a data packet in the vertical interval of the SDI signal and every line of the HD signal which contains a checksum of the entire video frame. This checksum is formed by adding up the numerical values of all of the samples in the frame, using a complex formula. At the destination this same formula is applied to the incoming video and the resulting value is compared to the one included in the transmission. If they match, then the content has all arrived with no errors. If they don't, then an error has occurred.

Embedded Audio

Digital Audio can be carried along in the same bitstream as an SDI or HD-SDI signal by taking advantage of the gaps in the transmission which correspond to the horizontal and vertical intervals of the television waveform. This technique can be very cost effective in transmission and routing, but can also add complexity to signal handling issues because the audio content can no longer be treated independently of the video.

Frame Sync

A Frame Synchronizer is used to synchronize the timing of a video signal to coincide with a timing reference (usually a color black signal that is distributed throughout a facility). The synchronizer accomplishes this by writing the incoming video into a frame buffer memory under the timing direction of the sync information contained in that video. Simultaneously the memory is being read back by a timing system that is gen-locked to a house reference. As a result, the timing or alignment of the video frame can be adjusted so that the scan of the upper left corner of the image is happening simultaneously on all sources. This is a requirement for both analog and digital systems in order to perform video effects or switch glitch-free in a router. Frame synchronization can only be performed within a single television line standard. A synchronizer will not convert an NTSC signal to a PAL signal, it takes a standards converter to do that.

Frequency Response

A measurement of the accuracy of a system to carry or reproduce a range of signal frequencies. Similar to Bandwidth.

IEC

The International Electrotechnical Commission provides a wide range of worldwide standards. They have provided standardization of the AC power connection to products by means of an IEC line cord. The connection point uses three flat contact blades in a triangular arrangement, set in a rectangular connector. The IEC specification does not dictate line voltage or frequency. Therefore, the user must take care to verify that a device either has a universal input (capable of 90 to 230 volts, either 50 or 60 Hz), or that a line voltage switch, if present, is set correctly.

Interlace

Human vision can be fooled to see motion by present a series of images, each with a small change relative to the previous image. In order to eliminate the flicker, our eyes need to see more than 30 images per second. This is accomplished in television systems by dividing the lines that make up each video frame (which run at 25 or 30 frames per second) into two fields. All of the odd-numbered lines are transmitted in the first field, the even-numbered lines are in the second field. In this way, the repetition rate is 50 or 60 Hz, without using more bandwidth. This trick has worked well for years, but it introduces other temporal artifacts. Motion pictures use a slightly different technique to raise the repetition rate from the original 24 frames that make up each second of film—they just project each one twice.

IRE

Video level is measured on the IRE scale, where 0 IRE is black, and 100 IRE is full white. The actual voltages that these levels correspond to can vary between formats.

ITU-R 601

This is the principal standard for standard definition component digital video. It defines the luminance and color difference coding system that is also referred to as 4:2:2. The standard applies to both PAL and NTSC derived signals. They both will result in an image that contains 720 pixels horizontally, with 486 vertical pixels in NTSC, and 576 vertically in PAL. Both systems use a sample clock rate of 27 Mhz, and are serialized at 270 Mb/s.

Jitter

Serial digital signals (either video or audio) are subject to the effects of jitter. This refers to the instantaneous error that can occur from one bit to the next in the exact position each digital transition. Although the signal may be at the correct frequency on average, in the interim it varies. Some bits come slightly early, other come slightly late. The measurement of this jitter is given either as the amount of time uncertainty or as the fraction of a bit width. For 270 Mb/s video, the allowable jitter is 740 picoseconds, or 0.2 UI (Unit Interval – one bit width).

Luminance

The “black & white” content of the image. Human vision had more acuity in luminance, so television systems generally devote more bandwidth to the luminance content. In component systems, the luminance is referred to as Y.

Multi-mode

Multi-mode fibers have a larger diameter core than single mode fibers (either 50 or 62.5 microns compared to 9 microns), and a correspondingly larger aperture. It is much easier to couple light energy into a multi-mode fiber, but internal reflections will cause multiple “modes” of the signal to propagate down the fiber. This will degrade the ability of the fiber to be used over long distances.

See also Single mode.

NTSC

The color television encoding system used in North America was originally defined by the National Television Standards Committee. This American standard has also been adopted by Canada, Mexico, Japan, Korea, and Taiwan. (This standard is referred to disparagingly as Never Twice Same Color.)

Optical

An optical interface between two devices carries data by modulating a light source. This light source is typically a laser or laser diode (similar to an LED) which is turned on and off at the bitrate of the datastream. The light is carried from one device to another through a glass fiber. The fiber's core acts as a waveguide or lightpipe to carry the light energy from one end to another. Optical transmission has two very significant advantages over metallic copper cables. Firstly, it does not require that the two endpoint devices have any electrical connection to each other. This can be very advantageous in large facilities where problems with ground loops appear. And secondly, and most importantly, an optical interface can carry a signal for many kilometers or miles without any degradation or loss in the recovered signal. Copper is barely useful at distances of just 1000 feet.

Oversampling

A technique to perform digital sampling at a multiple of the required sample rate. This has the advantage of raising the Nyquist Rate (the maximum frequency that can be reproduced by a given sample rate) much higher than the desired passband. This allows more easily realized anti-alias filters.

PAL

During the early days of color television in North America, European broadcasters developed a competing system called Phase Alternation by Line. This slightly more complex system is better able to withstand the differential gain and phase errors that appear in amplifiers and transmission systems. Engineers at the BBC claim that it stands for Perfection At Last.

Progressive

An imaging scanning technique that progresses through all of the lines of a frame in a single pass. Computer monitors all use progressive displays. This contrasts to the Interlace technique common to television systems.

Return Loss

An idealized input or output circuit will exactly match its desired impedance (generally 75 ohms) as a purely resistive element, with no reactive (capacitive or inductive) elements. In the real world, we can only approach the ideal. So, our real inputs and outputs will have some capacitance and inductance. This will create impedance matching errors, especially at higher frequencies. The Return Loss of an input or output measures how much energy is returned (reflected back due to the impedance mismatch.) For digital circuits, a return loss of 15 dB is typical. This means that the energy returned is 15 dB less than the original signal. In analog circuits, a 40 dB figure is expected.

RGB

RGB systems carry the totality of the picture information as independent Red, Green, and Blue signals. Television is an additive color system, where all three components add to produce white. Because the luminance (or detail) information is carried partially in each of the RGB channels, all three must be carried at full bandwidth in order to faithfully reproduce an image.

ScH Phase

Used in composite systems, ScH Phase measures the relative phase between the leading edge of sync on line 1 of field 1 and a continuous subcarrier sine wave. Due to the arithmetic details of both PAL and NTSC, this relationship is not the same at the beginning of each frame. In PAL, the pattern repeats every 4 frames (8 fields) which is also known as the Bruch Blanking sequence. In NTSC, the repeat is every 2 frames (4 fields.) This creates enormous headaches in editing systems and the system timing of analog composite facilities.

SDI

Serial Digital Interface. This term refers to inputs and outputs of devices that support serial digital component video. This generally means standard definition at 270 Mb/s. The use of “HD-SDI” is beginning to appear to indicate High Definition Serial Digital Video at 1.485 Gb/s.

SMPTE

The Society of Motion Picture and Television Engineers is a professional organization which has done tremendous work in setting standards for both the film and television industries. The term “SMPTE” is also shorthand for one particular component video format - luminance and color difference.

Single mode

A Single mode (or monomode) optical fiber carries an optical signal on a very small diameter (9 micron) core surrounded with cladding. The small diameter means that no internally reflected lightwaves will be propagated. Thus only the original “mode” of the signal passes down the fiber. A single mode fiber used in an optical SDI system can carry a signal for up to 20 kilometers. Single mode fibers require particular care in their installation due to the extremely small optical aperture that they present at splice and connection points.

See also Multi-mode.

TBC

A Time Base Corrector is a system to reduce the Time Base Error in a signal to acceptable levels. It accomplishes this by using a FIFO (First In, First Out) memory. The incoming video is written into the memory using its own jittery timing. This operation is closely associated with the actual digitization of the analog signal because the varying position of the sync timing must be mimicked by the sampling function of the analog to digital converter. A second timing system, gen-locked to a stable reference, is used to read the video back out of the memory. The memory acts as a dynamically adjusting delay to smooth out the imperfections in the original signal’s timing. Very often a TBC will also function as a Frame Synchronizer.

See also: Frame Sync.

Time Base Error

Time base error is present when there is excessive jitter or uncertainty in the line to line output timing of a video signal. This is commonly associated with playback from video tape recorders, and is particularly severe with consumer type heterodyne systems like VHS. Time base error will render a signal unusable for broadcast or editing purposes.

Tri-Level Sync

An analog sync reference signal that is used in High Definition systems. Tri Level Sync is constructed with three signal levels, the sync pulses extend above and below a mid-level average voltage (the blanking level). Unlike conventional analog sync which is bi-level, the proper 50% pickoff point is already identified in Tri Level Sync. This contributes to lower jitter in digital systems.

YUV

Strictly speaking, YUV does not apply to component video. The letters refer to the Luminance (Y), and the U and V encoding axes using in the PAL composite system. Since the U axis is very close to the B-Y axis, and the V axis is very close to the R-Y axis, YUV is often used as a sort of shorthand for the more long-winded "Y/R-Y/B-Y".

Y/Cr/Cb

In digital component video, the luminance component is Y, and the two color difference signals are Cr (R-Y) and Cb (B-Y).

Y/Pr/Pb

In analog component video, the image is carried in three components. The luminance is Y, the R-Y color difference signal is Pr, and the B-Y color difference signal is Pb.