



# BrightEye™ 55

## Genlockable Sync Generator and Test Signal Generator User Guide

**ENSEMBLE**  
DESIGNS

Revision 3.1 SW v1.0.2

This user guide provides detailed information for using the **BrightEye 55** Genlockable Sync Generator and Test Signal Generator unit.

The information is organized into the following sections:

- Product Overview
- Functional Description
- Applications
- Rear Connectors
- Operation
  - Front Panel Controls and Indicators
  - Using the BrightEye Control Application
- Adjustments
- Warranty and Factory Service
- Specifications
- Glossary

## PRODUCT OVERVIEW

BrightEye 55 is a genlockable sync and test signal generator that can be used as either a slave or master reference generator. It can lock to house reference or it can lock to its own internal precision standard. BrightEye 55 is well suited for any application requiring genlocking of signals to a house reference as well as remote trucks, desktop, and fly packs.

A variety of test signals including three color black variations, three color bar variations, Safe Title, four sweep (multi-burst) variations, and several choices for a user selectable test signal (selectable in BrightEye PC or Mac) are available on the SDI and analog outputs.

A Slate ID with user-programmable text can overlay the test pattern output. The cyclops feature adds a motion element on the video test signal, handy for live applications.

The HD Tri Level Sync output provides reference to high definition equipment, such as VTRs, disc recorders, and workstations. User-selectable formats include 720p, 1080i, 1080sF, and 1080p. Format selections and other controls are accessed through the BrightEye Control application.

AES3id digital audio, analog audio with level adjustment, and embedded audio reference outputs are provided.

A glossary of commonly used video terms is provided at the end of this manual.

## FUNCTIONAL DESCRIPTION

The BrightEye 55 can lock to an external house reference or it can lock to its own internal precision standard reference. Refer to the block diagram on the next page while reading this section.

The Ref In BNC on the rear of the unit will accept an external PAL or NTSC composite video signal as a reference. If a valid reference is detected on the Ref In BNC, the unit switches to this reference automatically. The SDI, Tri Level Sync, and AES outputs will all be synchronous relative to this reference. The overall vertical and horizontal timing of the outputs can be adjusted in the BrightEye PC or Mac Timing menu. Reference status is reported on the front of the unit and in BrightEye PC or Mac. The Composite video output will have the same Sch phase (or color framing) as the external reference.

A special case exists when simultaneously using PAL and NTSC. If the output standard for the module is PAL and an NTSC reference is connected, BrightEye 55 will lock to the reference at the fundamental clock frequency common to PAL and NTSC. This is referred to as "clock-locked". There is no horizontal and vertical relationship but BrightEye 55 will have the same frequency accuracy as the reference and the AES audio output will be synchronous simultaneously to the BrightEye 55 PAL output and the NTSC reference. The same case is true for an NTSC standard with a PAL reference.

When no external reference is connected to the unit, the fundamental clock source for BrightEye 55 is taken from a temperature compensated oscillator which guarantees frequency accuracy to within 1 cycle of subcarrier (better than 0.2 ppm) across the full operating temperature range. In addition, because it does not require a crystal oven, BrightEye 55 is accurate immediately upon power up. This ensures that the BrightEye 55 outputs meet the most stringent standards.

The external reference or master clock drives the Sync Gen block. The reference choice is user configured for 525 (NTSC) or 625 (PAL) line rates. The standard definition output feeds horizontal and vertical sync to the internal Test Signal Generator.

The HD Tri Level Sync Gen block is further user configured in BrightEye PC or Mac to one of four HD formats (**1080i**, **1080p**, **720p**, or **1080sF**). The Tri Level Sync output frame rate can be selected from two choices in BrightEye PC or Mac, **23.98/50/59.94**, the most commonly used, and **24/30/60**, a frame rate reserved for use with special applications such as film.

The module will apply the selected Tri Level Sync frame rates to specific formats and line rates as shown in the table below.

Frame Rate	23.98/50/59.94 Hz		24/30/60 Hz	
	NTSC	PAL	NTSC	PAL
<b>1080i</b>	59.94	50	60	50
<b>720p</b>	59.94	50	60	50
<b>1080p</b>	23.98	25	24	25
<b>1080sF</b>	23.98	25	24	25

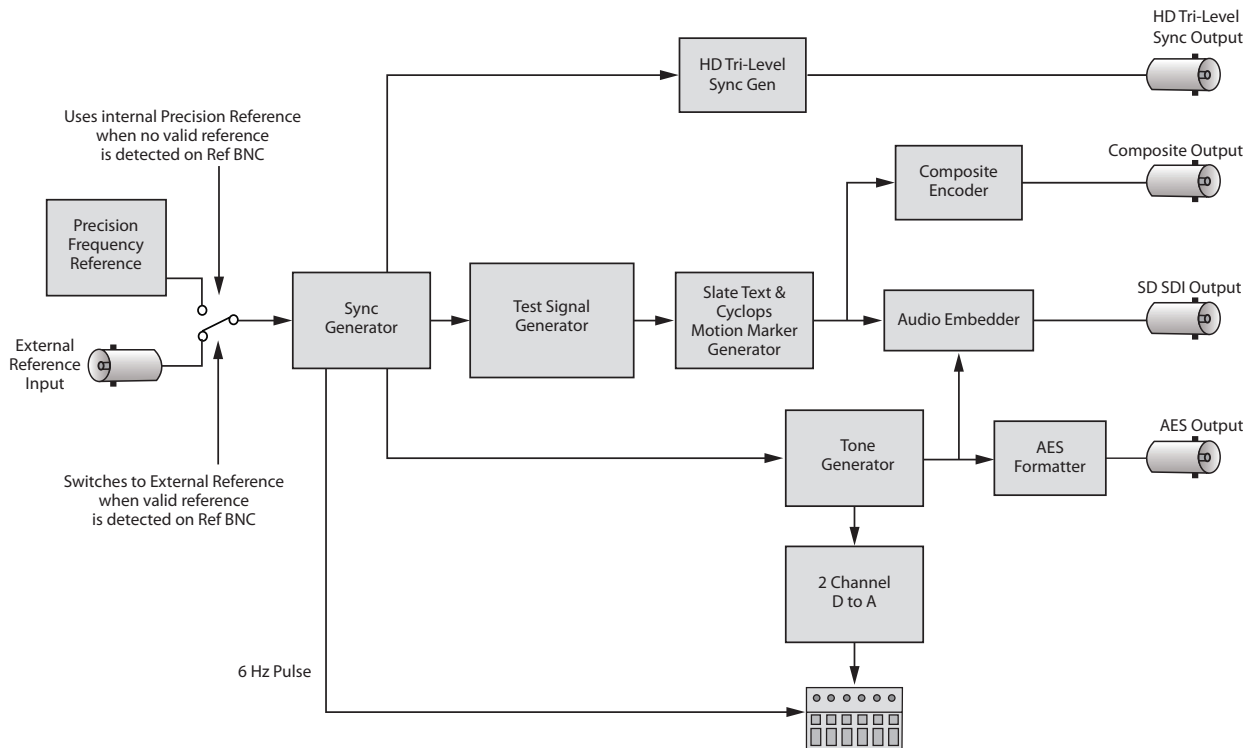

BrightEye 55 Functional Block Diagram, Portrait View

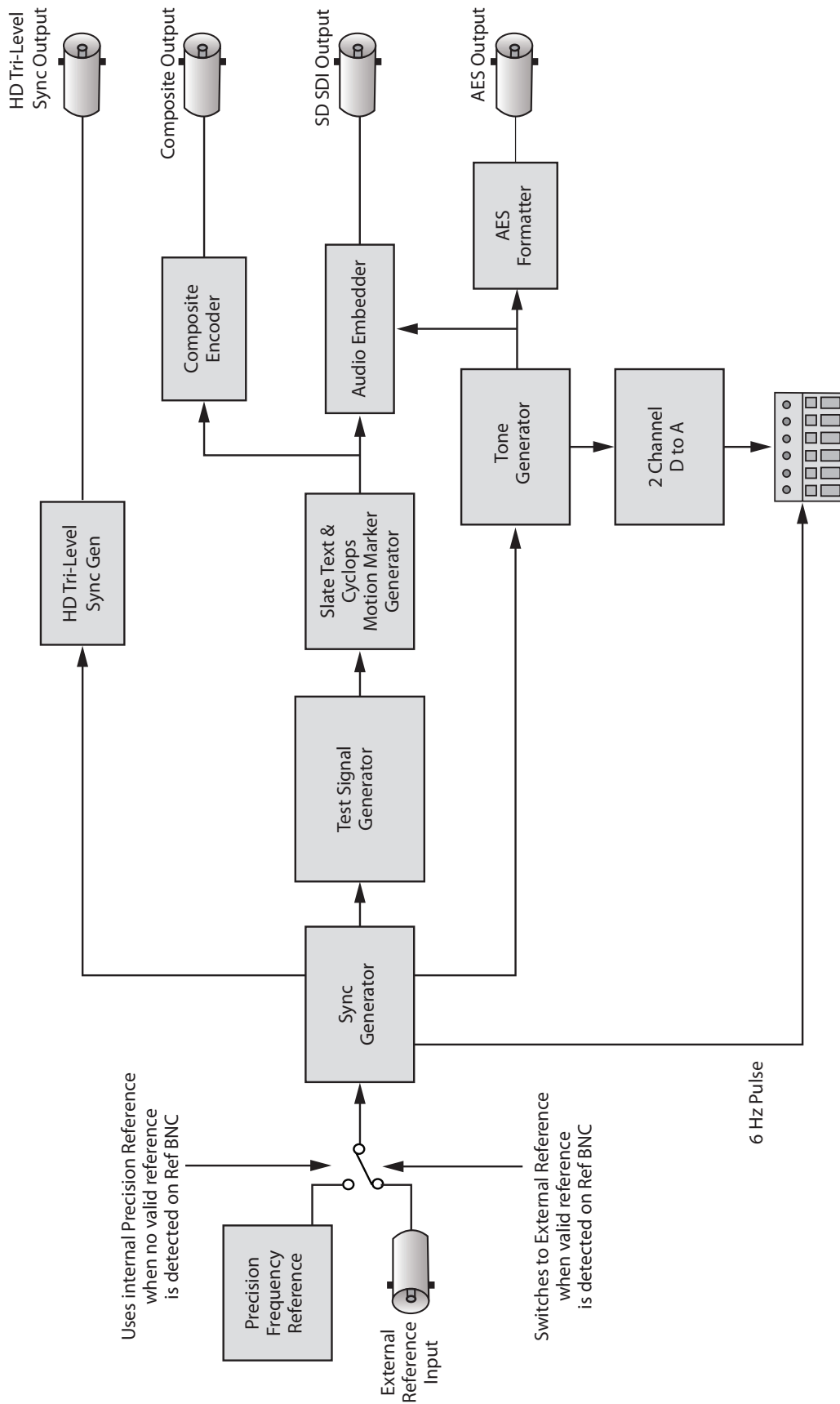

BrightEye 55 Functional Block Diagram, Landscape View

The Sync Gen section also has an output which indicates coincidence between the vertical intervals of the SD and HD outputs. In all formats except 1080sF/23.98, the vertical intervals will be coincidental in every field or frame. In 1080sF/23.98 that coincidence occurs once for every 4 sF frames and every 5 SD (NTSC) frames. Accordingly, this coincidence marker occurs at a 6 Hertz rate, and is commonly referred to as a 6 Hz pulse.

The Tone Generator is also locked to the master clock or the external reference, so the 48 KHz AES output will be synchronous to the video outputs. In NTSC there are exactly 8008 audio samples in every five video frames. There will be exactly 1920 audio samples in every PAL video frame.

The Tone Generator can be configured for a 1.0 KHz continuous tone, or an interrupted tone which is coordinated with the Cyclops moving element. The Tone Generator feeds the Analog Audio outputs through a precision digital to analog converter. It feeds an AES formatter to produce a standard AES output. And finally, it is fed to an audio embedder so that it's present in the SDI output.

The user-selected test signal is produced in the Test Signal Gen block. The test signal then passes to the Slate ID Text Generator which can overlay a line of user programmable text across the test pattern. This block also has the Cyclops Motion Marker which adds a moving element to the image.

This video signal is combined with the output of the Tone Generator to produce a serial digital (SDI) output.

The same video signal is digitally encoded to composite video and converted to analog form to drive the Analog Composite output.

BrightEye 55 is powered by a 12 volt DC universal power supply. This power supply can accept an input voltage between 90 and 230 volts, at 50 or 60 Hertz. It uses a standard IEC line cord and can be used anywhere in the world. It is normal for the converter to be warm to the touch when operating.

## APPLICATIONS

BrightEye 55's complete feature set makes it a versatile genlock sync and test signal generator. Its small size also makes it an excellent choice for use in mobile applications. An example of a BrightEye 55 application is given below.

### Genlocked Test Signals

With the external reference capability, BrightEye 55 can be used to input test signals to facility devices timed to the same house reference. A number of test signals can be fed to a router, switcher, and other devices in a facility where genlocked timing is important.

As shown in the example below, a BrightEye 55 is fed with the house reference to the **Ref In** BNC. The audio tone can be embedded into the SDI timed test signal output and fed to an SDI router and switcher. This allows each of the test signals to be in time with the signals fed to the other devices.

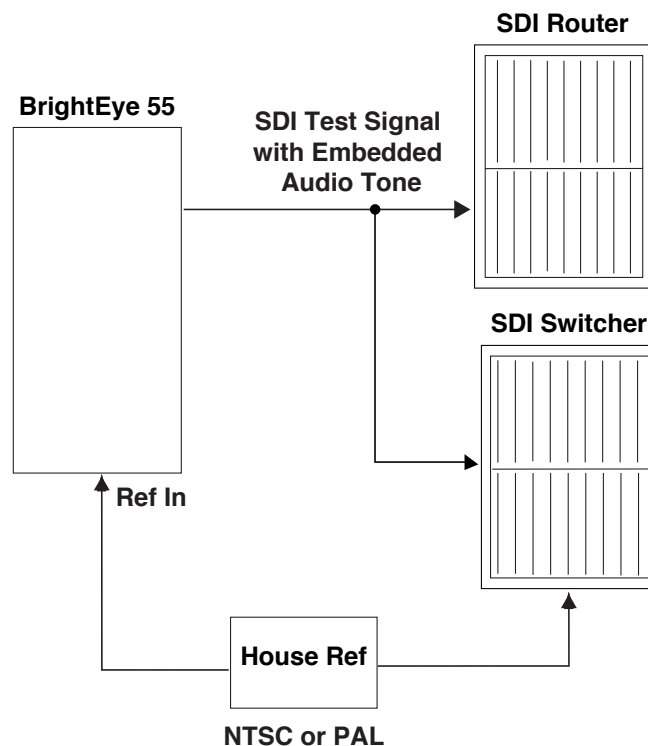

BrightEye 55 Genlocked Test Signal Application

## REAR CONNECTORS

All connections to the BrightEye 55 converter are made on the rear of the unit. Refer to the illustration below.

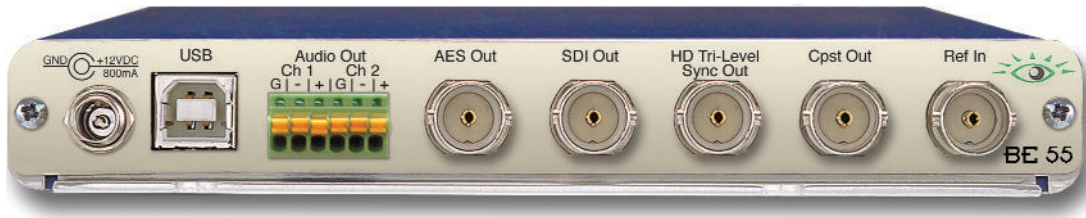

**BrightEye 55 Rear Connectors**

### Power Connection

Connect a modular power supply to the 12 volt DC power input connection on the far left of the unit. Use the locking ring to secure it.

### USB Connector

The USB connector is used to provide more comprehensive control, diagnostics, and upgrades to the unit from a PC or Mac. Use the BrightEye Control application included on CD-ROM to make adjustments as described in the **OPERATION** section of this user guide.

### Audio Out

The **Audio Out** provides two channels of an analog audio reference tone. Wiring is done by inserting a 6 pin connector provided with the unit. Analog reference levels can be configured from the BrightEye Control application. The pinouts for the audio connector provided are shown in the diagram below.

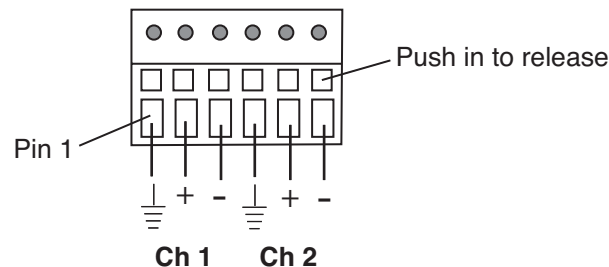

**Audio Output Connector**

To connect audio to this connector type, strip the audio wire to about 3/8" (8 mm). Solder tinning is not required. Push the wire into the opening at the bottom of the connector to seat the connection. This will snap the wire into place.

To remove the wire, push in the pin above the connection with a small pointed tool. This will release the wire from the connector.

**Balanced Analog Audio Connection** – to connect the audio output to an audio XLR connector, connect the pins as follows:

- Attach Ground from Pin 1 of the Audio Out to Pin 1 of the XLR.
- Attach the + (plus) signal from Pin 2 of the Audio Out to Pin 2 of the XLR.
- Attach the – (minus) signal from Pin 3 of the Audio Out to Pin 3 of the XLR.

**For Unbalanced Audio to a RCA Phono Input** – to connect the audio output to a consumer audio connector such as an RCA phono jack, connect the pins as follows:

- Attach Ground from Pin 1 of the Audio Out to the shell, Shield or Ground of the RCA Phono jack.
- Attach the + (plus) signal from Pin 2 of the Audio Out to the center pin of the RCA Phono jack.
- The – (minus) signal is not used in this application.

### **AES Out**

The **AES Out** is a BNC connector that provides a digital audio output in the AES format. The AES Output can be configured from the front panel and from the BrightEye Control application.

### **HD Tri Level Sync Out**

The **HD Tri Level Sync Out** is an output BNC connector that supplies HD Tri Level Sync in a number of user selected formats. Either the front panel or the BrightEye PC or Mac can be used to select the desired format. One of two different TLS output frame rates can be selected in the BrightEye PC or Mac **Config** menu (**23.98/50/59.94** or **24/30/60**).

### **SDI Out**

The **SDI Out** is a BNC connector that provides test patterns or black in serial digital component format. Test patterns and video standard can be selected from the front panel as well as the BrightEye Control application. This output conforms to the ITU-R 601 standard for serial digital video, with SMPTE 259M serialization at 270 Mb/s. The AES audio test signals can be embedded in this signal using BrightEye PC or Mac controls.

### **Cpst Out (Composite Out)**

The **Cpst Out** is a BNC connector that presents either NTSC or PAL composite output. This output provides the same test pattern as **SDI Out**, only in composite format. The test pattern can be selected from the front panel and the BrightEye Control application.

### **Ref In (Reference In)**

The **Ref In** BNC will accept a PAL or NTSC reference input to provide an overall genlock timing reference for the unit.



## OPERATION

Control and operation of the BrightEye 55 is performed from the front panel and with the BrightEye Control application.

**NOTE:** *Some control settings and parameter choices are only available with BrightEye PC or Mac. These parameters cannot be monitored from the front panel.*

### Front Panel Controls and Indicators

The front panel shown in the figure below provides status indicators and control over video and audio output.



**BrightEye 55 Front Panel**

#### Status Indicators

The following status indicators are provided on the front panel:

##### Std (Standard)

The currently selected output standard (**NTSC** or **PAL**) will illuminate green.

##### Ref (Reference)

The status indicator will be green when a valid reference is present and locked.

##### Video

The currently selected video pattern **Black** (choices include **Black**, **Flat 20%**, **Flat 80%**), **Bars** (choices include **75% Bars**, **100% Bars**, **SMPTE Bars**), **Safe** (**Safe Title**), **Sweep** (choices include **Sweep**, **Mono Sweep**, **MultiBurst**, **Mono Burst**), or **User** (chosen in BrightEye PC or Mac) will illuminate green.

Selection of these different choices can be made from the front panel and in BrightEye PC or Mac as explained next in the **Controls** section of this manual.

##### Slate

Illuminates green when the signal identification slate is enabled. To change the Slate text ID, use the **Config** menu in the BrightEye Control application.

##### Tone

Illuminates green when analog audio tone is enabled.

### **HD Sync**

The currently selected HD Tri Level Sync format (**1080i**, **720p**, **1080p**, or **1080sF**) is illuminated green. One of two different Tri Level Sync (TLS) frame rates can be selected in the **Config** menu of the BrightEye Control application as **23.98/50/59.94** (the most commonly used, default value) or **24/30/60** (for special applications such as film).

### **Pwr (Power)**

Illuminates green when power is applied to the unit and the internal voltage regulator is functioning correctly.

## **ADJUSTING PARAMETERS FROM THE FRONT PANEL**

Use the **Mode**, **Right Arrow**, and **Left Arrow** buttons to select and adjust parameters from the front panel.

Pressing the **Mode** button activates the front panel for editing and tabs between each section of editable parameters.

Pressing the **Right Arrow** or **Left Arrow** advances the selection within a given section of parameters, or increases (Right Arrow) or decreases (Left Arrow) the value of a selected parameter.

**NOTE:** The LED of an edited parameter will blink for 15 seconds, after which time its value is stored in memory. If power is interrupted before this 15 second timeout period has elapsed, the edited state will not be saved.

The LED indicators will report the following:

- **Std (Standard) select** – currently selected video output standard blinks.
- **Ref** – illuminates green when a valid NTSC or PAL reference is detected. Off when no reference is detected.
- **Video** – currently selected video pattern (or pattern group) output blinks.
- **Slate on/off** – blinks quickly when ID slate is enabled, slowly when disabled.
- **Tone on/off** – blinks quickly when tone is enabled, slowly when disabled.
- **HD Sync select** – currently selected HD Tri Level Sync format blinks.

The controls and their indicators are described below:

### **Std (Standard)**

This control selects the video output standard with the following choices:

**NTSC** – 525 NTSC standard

**PAL** – 625 PAL standard

## Video

This control selects the video test pattern with the following choices:

- Black choices: **Black**, **Flat 20%**, or **Flat 80%**.
- Bar choices: **75% Bars**, **100% Bars**, or **SMPTE Bars**.
- Sweep choices: **Sweep**, **Mono Sweep**, **Multi Burst**, or **Mono Burst**.
- User choices – This pattern can be specified in the **Test Pattern** menu, providing over eight additional patterns (**Pathological**, **Pulse and Bar**, **Ramp**, **Digital Blanking**, **Analog Blanking**, **Interlace**, **Crosshatch**, and **Unit Circle**).

**NOTE:** Mono Sweep and Mono Burst are recommended for analog applications and Sweep and Multi Burst for SDI video applications.

## Slate

This control allows the identification slate on the test signal output to be turned on and off. The content of the slate can be configured in the **Config** menu in the BrightEye Control application.

## Tone

This control toggles the analog audio tone on and off. This applies to the analog audio out, the AES out, and the embedded tone on the SDI out. Advanced configuration of digital and analog audio reference levels is available in the **Config** menu in the BrightEye Control application.

## HD Sync

This control selects the HD Tri Level Sync standard. Select 1080i, 720p, 1080p, or 1080sF. This output also follows the output **Standard** selected, either 525 or 625. For more information, see the **FUNCTIONAL DESCRIPTION** section at the beginning of this manual.

## USING THE BRIGHT EYE CONTROL APPLICATION

The BrightEye PC and BrightEye Mac applications included on CD-ROM are designed to allow you to configure and control the BrightEye 55 from a personal computer. Installation and instructions for using this software application are given in the PDF manual on disk. If the BrightEye 55 is connected to a computer running this software, the following menus are available for controlling and monitoring the unit:

### Test Pattern Menu

- **Test Pattern** – select the type of test pattern from the pulldown: **Black**, **Flat 20%**, **Flat 80%**, **75% Bars**, **100% Bars**, **SMPTE Bars**, **Safe Title**, **Sweep**, **Mono Sweep**, **Multi Burst**, **Mono Burst**, or **User** (defined under **User Pattern**).
- **User Pattern** – selects the pattern displayed when **Test Pattern** is set to **User**. This pulldown lets you chose between: **Pathological**, **Pulse and Bar**, **Ramp**, **Digital Blanking**, **Analog Blanking**, **Interlace**, **Crosshatch**, and **Unit Circle**.
- **Y, Cr, and Cb Channels** – these check boxes allow you to selectively disable the output in particular luminance and color channels.
- **ID and ID Mode** – these pulldowns control signal identification. Use **ID** to turn signal identification **On** or **Off**. **ID Mode** selects between **Slate Only**, **Cyclops Only**, or **Slate & Cyclops**. The content of the **ID Slate** can be controlled from the **Config Menu**.
- **Tone and Tone Mode** – these pulldowns control audio tone generation. **Tone** turns tone generation **On** or **Off**. **Tone Mode** selects the style of tone generated. Select between **Continuous**, **Pop**, or **Beep**.
- **Embedding** – turning this control **On** embeds the audio test tone into the SDI output. Turning it **Off**, does not embed the audio test tone.

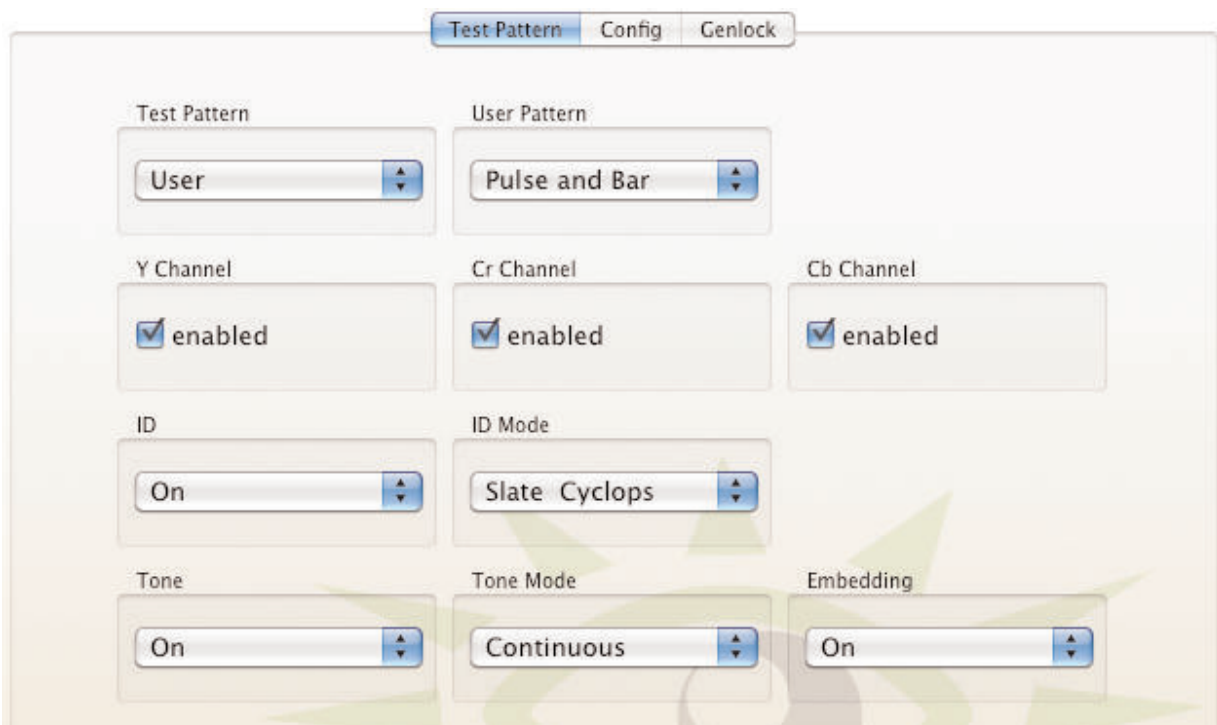

## Config Menu

Use the Config menu shown below to set the following parameters:

- **Standard** – select the output standard for SDI and composite video. This pulldown lets you choose between: **NTSC (525)** and **PAL (625)**.
- **HD Standard** – select the HD Tri Level Sync standard. This pulldown lets you choose between: **1080i**, **720p**, **1080p**, or **1080sF**.
- **Setup** – turn **Setup On** or **Off** for 525 60Hz signals.
- **Slate Text** - the contents of this text field will be displayed in the **ID Slate**. Enter up to 19 characters.
- **Dig Ref Level** – select the digital audio reference level. This pulldown lets you choose between: **-18dBFS** or **-20dBFS**.
- **Analog Ref Level** – select the analog audio reference level. This pulldown lets you choose between: **-10 dB**, **-6 dB**, **-4 dB**, **0 dB**, or **+4 dB**.
- **TLS Framerate** – this control allows selection of the Tri Level Sync frame rate output between **23.98/50/59.94 Hz** and **24/30/60 Hz**. Refer to the discussion of this functionality in the **FUNCTIONAL DESCRIPTION** at the front of this document.
- **Freq Adjust** – this control temporarily enables the **Freq Adjust** control. When this control is set to **Allowed** the user has 20 seconds to begin adjusting the internal clock frequency, after 20 seconds this **Freq Adjust** is disabled.
- **Freq Adjust** – this control allows the internal timing source to be adjusted. See the **ADJUSTMENTS** section of this manual for more details and the adjustment procedure.

The screenshot shows the 'Config' menu of the BrightEye 55 device. At the top, there are three tabs: 'Test Pattern', 'Config' (which is active), and 'Genlock'. Below the tabs, the settings are organized into several sections:

- Standard:** A dropdown menu showing '525 - NTSC'.
- HD Standard:** A dropdown menu showing '1080i'.
- Setup:** A dropdown menu showing 'On'.
- Slate Text:** A text input field containing 'BrightEye 55'.
- Dig Ref Level:** A dropdown menu showing '-20dBFS'.
- Anlg Ref Level:** A dropdown menu showing '+4 dB'.
- TLS Framerate:** A dropdown menu showing '23.98 / 50 / 59...'.
- Freq Adjust:** A dropdown menu showing 'Disabled'.
- Freq Adjust:** A numeric input field showing '0'.

### Genlock Menu

Use the Genlock menu shown below to set the following parameters:

- **Reference** – The type of external reference connected to the Ref In BNC will be reported as **No Ref**, **525 Reference**, or **625 Reference**.
- **Ver Time** – set the output timing of all output signals to match the vertical timing in relation to the external reference connected to the **Ref In** BNC in lines.
- **Hor Time** – set the output timing of all output signals to match the horizontal timing in relation to the external reference connected to the **Ref In** BNC in clocks.

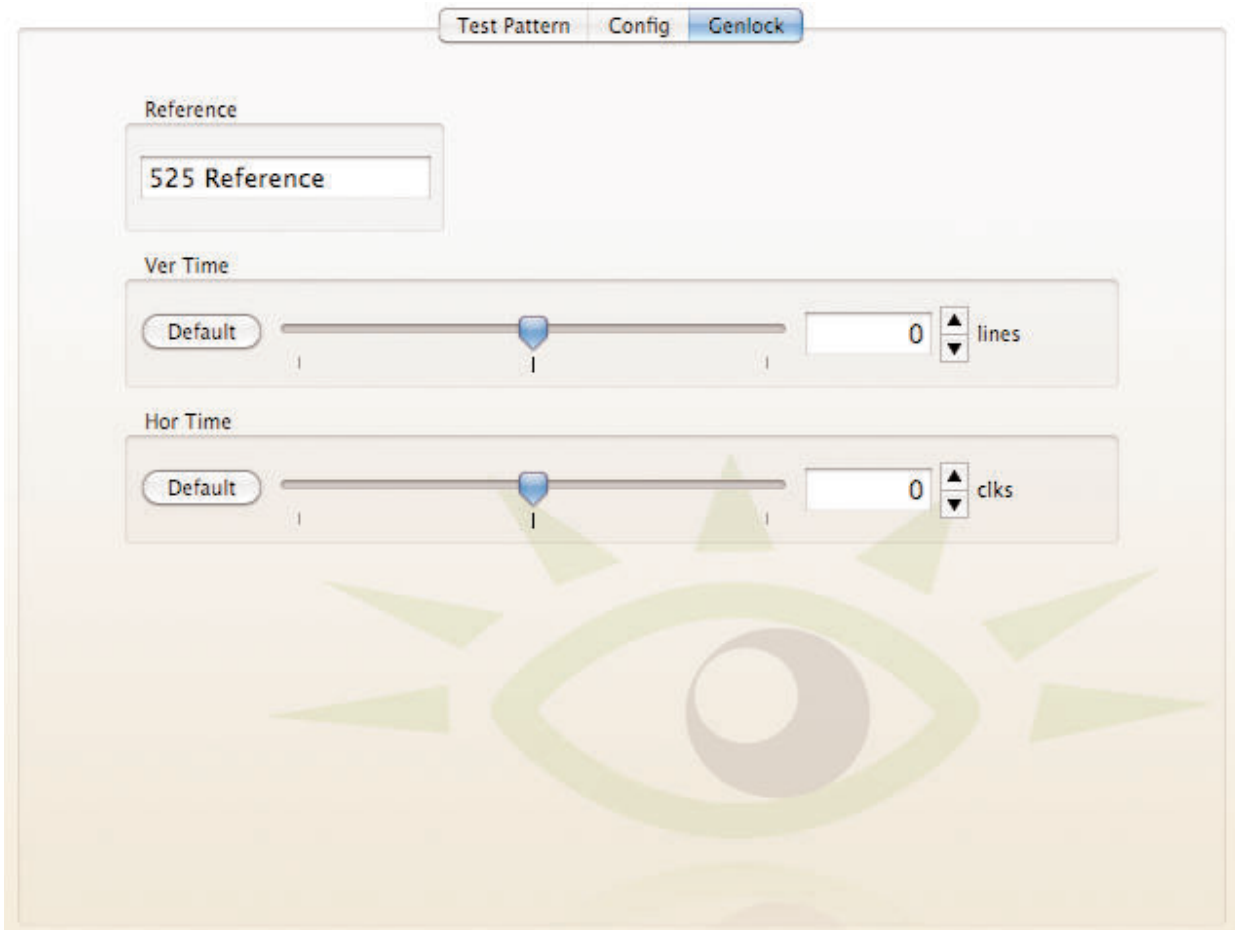

## ADJUSTMENTS

### Frequency Adjustment

The BrightEye 55 contains a precision timing source that is calibrated at the factory to meet full specifications for timing precision. However, because clock crystals shift frequency as they age, it may be necessary to adjust the frequency of the internal source. This adjustment should not be necessary until after several years of use.

### Frequency Adjustment Procedure

Connect the BrightEye 55's composite output to a vector scope that is externally referenced to a known accurate source generator. With the external reference enabled on the vectorscope, the vector display of the BrightEye 55 composite signal will slowly rotate.

At this point, use the BrightEye Control Application to enable **Freq Adjust** and adjust the frequency to bring the BrightEye 55 into spec by making the rotation of its vector slow or stop.

The specification of  $\pm 1\text{Hz}$  of subcarrier (in either PAL or NTSC) is met if the vector takes more than 1 second to make 1 full revolution.

The original factory adjustment is equal to a **Freq Adjust** value of 0.

## WARRANTY AND FACTORY SERVICE

### Warranty

Ensemble Designs, Inc. warrants this product to be free from defect in material and workmanship for a period of 5 years from the date of delivery. During this 5 year warranty period, Ensemble Designs, Inc. will repair any defective units at Ensemble Designs' expense if the unit should be determined to be defective after consultation with a factory technician.

This warranty is not transferable. Any implied warranties expire at the expiration date of this warranty.

This warranty does not cover a defect that has resulted from improper or unreasonable use or maintenance as determined by us. This warranty is void if there is any attempt to disassemble or adjust factory set presets without factory authorization.

### Factory Service

If you require service (under warranty or not), please contact Ensemble Designs and ask for Customer Service before you return the unit. This will allow the service technician to provide any other suggestions for identifying the problem and recommend possible solutions.

You may also refer to the technical support section of the Ensemble web site for the latest information on your equipment at the URL below:

<http://www.ensembledesigns.com/support>

If you return equipment for repair, please get a Return Material Authorization Number (RMA) from the factory first.

Ship the product and a written description of the problem to:

Ensemble Designs, Inc.

Attention: Customer Service RMA #####

870 Gold Flat Rd.

Nevada City, CA 95959 USA

(530) 478-1830

Fax: (530) 478-1832

[service@ensembledesigns.com](mailto:service@ensembledesigns.com)

<http://www.ensembledesigns.com>

Be sure to put your RMA number on the outside of the box.



## SPECIFICATIONS

### Reference Input

Number	One
Signal Type	1V P-P PAL, NTSC, or 10 MHz
Return Loss	>40 dB DC to 5.5 MHz

### Composite Output

Number	One
Signal Type	NTSC / PAL
Impedance	75 $\Omega$
Return Loss	>40 dB DC to 5.5 MHz
Frequency Response	-0.1 dB 10 KHz to 5.0 MHz
Output DC	$\pm 50$ mV
K Factors	< 1.0%
Differential Phase	< 1.0 degree
SCH Phase	$\pm 5$ degrees

### Accuracy and Timing Stability

Internal TCX0	
PAL Fsc	4.43361875 MHz +/- 1 Hz
NTSC Fsc	3.579545 MHz +/- 1 Hz
601 Fs	27.000000 MHz +/- 5 Hz
Long Term Drift	<1 ppm/year
Analog Jitter	<1 ns
Digital Jitter	<0.2 UI (0.13 UI typical)

### Serial Digital Output

Number	One
Signal Type	SMPTE 259M
Return Loss	> 15 dB to 270 MHz

### Tri Level Sync Output

Number	One, 75 $\Omega$
Type	1080i (SMPTE 274M -5, 6) 59.94, 50, 60 Hz 720p (SMPTE 296M -2, 3) 59.94, 50, 60 Hz 1080p (SMPTE 274M -9, 11) 23.98, 24, 25 Hz 1080sF (RP211 -14, 16) 23.98, 24, 25 Hz
Output DC	$\pm 50$ mV
Return Loss	> 30 dB to 30 MHz

### AES Output:

Number	One
Type	AES3id, 1 KHz tone
Resolution	24 bit

### Analog Audio Output

Number	One stereo pair or two mono
Type	1 KHz tone
Impedance	30 $\Omega$ , balanced
Reference Level	-10 to + 4 dBu, adjustable

### General Specifications

Size	5.625" W x 0.8" H x 5.5" D (143 mm x 20 mm x 140 mm) including connectors
Weight	15 oz
Power	12 volts, 4 watts (100-230 VAC modular power supply not included)
Temperature Range	0 to 40° C ambient
Relative Humidity	0 to 95%, non-condensing

Due to ongoing product development, all specifications are subject to change.

## **BRIGHTEYE POWER SUPPLY INFORMATION**

Below is a list of power supplies and optional items that may have come with your BrightEye:

### **BEPS**

BrightEye Individual Power Supply.

### **BEPS6**

Spider Power Supply. This powers 6 single high BrightEyes or 3 double high BrightEyes.

### **BEPS6-RP**

Redundant Power Supply for Spider.

### **BERKMT**

BrightEye Rack Mount. This holds 6 single high BrightEyes or 3 double high BrightEyes, or a combination.

### **BEBP**

BrightEye Blank Panel. Single high, for empty slots in Rack Mount.

### **BEAC**

Analog Audio Breakout Cable.

## GLOSSARY

This is a brief glossary of commonly used terms associated with this product.

### **AES/EBU**

The digital audio standard defined as a joint effort of the Audio Engineering Society and the European Broadcast Union. AES/EBU or AES3 describes a serial bitstream that carries two audio channels, thus an AES stream is a stereo pair. The AES/EBU standard covers a wide range of sample rates and quantizations (bit depths.) In television systems, these will generally be 48 KHz and either 20 or 24 bits.

### **Bandwidth**

Strictly speaking, this refers to the range of frequencies (i.e. the width of the band of frequency) used by a signal, or carried by a transmission channel. Generally, wider bandwidth will carry and reproduce a signal with greater fidelity and accuracy.

### **Beta**

Sony Beta SP video tape machines use an analog component format that is similar to SMPTE, but differs in the amplitude of the color difference signals. It may also carry setup on the luminance channel.

### **Blanking**

The Horizontal and Vertical blanking intervals of a television signal refer to the time periods between lines and between fields. No picture information is transmitted during these times, which are required in CRT displays to allow the electron beam to be repositioned for the start of the next line or field. They are also used to carry synchronizing pulses which are used in transmission and recovery of the image. Although some of these needs are disappearing, the intervals themselves are retained for compatibility purposes. They have turned out to be very useful for the transmission of additional content, such as teletext and embedded audio.

### **CAV**

Component Analog Video. This is a convenient shorthand form, but it is subject to confusion. It is sometimes used to mean ONLY color difference component formats (SMPTE or Beta), and other times to include RGB format. In any case, a CAV signal will always require three connectors – either Y/R-Y/B-Y, or R/G/B.

### **Checkfield**

A Checkfield signal is a special test signal that stresses particular aspects of serial digital transmission. The performance of the Phase Locked-Loops (PLLs) in an SDI receiver must be able to tolerate long runs of 0's and 1's. Under normal conditions, only very short runs of these are produced due to a scrambling algorithm that is used. The Checkfield, also referred to as the Pathological test signal, will “undo” the scrambling and cause extremely long runs to occur. This test signal is very useful for testing transmission paths.

## **Chroma**

The color or chroma content of a signal, consisting of the hue and saturation of the image. See also Color Difference.

## **Component**

In a component video system, the totality of the image is carried by three separate but related components. This method provides the best image fidelity with the fewest artifacts, but it requires three independent transmission paths (cables). The commonly used component formats are Luminance and Color Difference (Y/Pr/Pb), and RGB. It was far too unwieldy in the early days of color television to even consider component transmission.

## **Composite**

Composite television dates back to the early days of color transmission. This scheme encodes the color difference information onto a color subcarrier. The instantaneous phase of the subcarrier is the color's hue, and the amplitude is the color's saturation or intensity. This subcarrier is then added onto the existing luminance video signal. This trick works because the subcarrier is set at a high enough frequency to leave spectrum for the luminance information. But it is not a seamless matter to pull the signal apart again at the destination in order to display it or process it. The resultant artifacts of dot crawl (also referred to as chroma crawl) are only the most obvious result. Composite television is the most commonly used format throughout the world, either as PAL or NTSC. It is also referred to as Encoded video.

## **Color Difference**

Color Difference systems take advantage of the details of human vision. We have more acuity in our black and white vision than we do in color. This means that we need only the luminance information to be carried at full bandwidth, we can scrimp on the color channels. In order to do this, RGB information is converted to carry all of the luminance (Y is the black and white of the scene) in a single channel. The other two channels are used to carry the "color difference". Noted as B-Y and R-Y, these two signals describe how a particular pixel "differs" from being purely black and white. These channels typically have only half the bandwidth of the luminance.

## **Decibel (dB)**

The decibel is a unit of measure used to express the ratio in the amplitude or power of two signals. A difference of 20 dB corresponds to a 10:1 ratio between two signals, 6 dB is approximately a 2:1 ratio. Decibels add while the ratios multiply, so 26 dB is a 20:1 ratio, and 14 dB is a 5:1 ratio. There are several special cases of the dB scale, where the reference is implied. Thus, dBm refers to power relative to 1 milliwatt, and dBu refers to voltage relative to .775V RMS. The original unit of measure was the Bel (10 times bigger), named after Alexander Graham Bell.

## **dBFS**

In Digital Audio systems, the largest numerical value that can be represented is referred to as Full Scale. No values or audio levels greater than FS can be reproduced because they would be clipped. The nominal operating point (roughly corresponding to 0 VU) must be set below FS in order to have headroom for audio peaks. This operating point is described relative to FS, so a digital reference level of -20 dBFS has 20 dB of headroom before hitting the FS clipping point.

## **EDH**

Error Detection and Handling is a method to verify proper reception of an SDI or HD-SDI signal at the destination. The originating device inserts a data packet in the vertical interval of the SDI signal and every line of the HD signal which contains a checksum of the entire video frame. This checksum is formed by adding up the numerical values of all of the samples in the frame, using a complex formula. At the destination this same formula is applied to the incoming video and the resulting value is compared to the one included in the transmission. If they match, then the content has all arrived with no errors. If they don't, then an error has occurred.

## **Embedded Audio**

Digital Audio can be carried along in the same bitstream as an SDI or HD-SDI signal by taking advantage of the gaps in the transmission which correspond to the horizontal and vertical intervals of the television waveform. This technique can be very cost effective in transmission and routing, but can also add complexity to signal handling issues because the audio content can no longer be treated independently of the video.

## **Frame Sync**

A Frame Synchronizer is used to synchronize the timing of a video signal to coincide with a timing reference (usually a color black signal that is distributed throughout a facility). The synchronizer accomplishes this by writing the incoming video into a frame buffer memory under the timing direction of the sync information contained in that video. Simultaneously the memory is being read back by a timing system that is genlocked to a house reference. As a result, the timing or alignment of the video frame can be adjusted so that the scan of the upper left corner of the image is happening simultaneously on all sources. This is a requirement for both analog and digital systems in order to perform video effects or switch glitch-free in a router. Frame synchronization can only be performed within a single television line standard. A synchronizer will not convert an NTSC signal to a PAL signal, it takes a standards converter to do that.

## **Frequency Response**

A measurement of the accuracy of a system to carry or reproduce a range of signal frequencies. Similar to Bandwidth.

## **IEC**

The International Electrotechnical Commission provides a wide range of worldwide standards. They have provided standardization of the AC power connection to products by means of an IEC line cord. The connection point uses three flat contact blades in a triangular arrangement, set in a rectangular connector. The IEC specification does not dictate line voltage or frequency. Therefore, the

user must take care to verify that a device either has a universal input (capable of 90 to 230 volts, either 50 or 60 Hz), or that a line voltage switch, if present, is set correctly.

### **Interlace**

Human vision can be fooled to see motion by presenting a series of images, each with a small change relative to the previous image. In order to eliminate the flicker, our eyes need to see more than 30 images per second. This is accomplished in television systems by dividing the lines that make up each video frame (which run at 25 or 30 frames per second) into two fields. All of the odd-numbered lines are transmitted in the first field, the even-numbered lines are in the second field. In this way, the repetition rate is 50 or 60 Hz, without using more bandwidth. This trick has worked well for years, but it introduces other temporal artifacts. Motion pictures use a slightly different technique to raise the repetition rate from the original 24 frames that make up each second of film—they just project each one twice.

### **IRE**

Video level is measured on the IRE scale, where 0 IRE is black, and 100 IRE is full white. The actual voltages that these levels correspond to can vary between formats.

### **ITU-R 601**

This is the principal standard for standard definition component digital video. It defines the luminance and color difference coding system that is also referred to as 4:2:2. The standard applies to both PAL and NTSC derived signals. They both will result in an image that contains 720 pixels horizontally, with 486 vertical pixels in NTSC, and 576 vertically in PAL. Both systems use a sample clock rate of 27 Mhz, and are serialized at 270 Mb/s.

### **Jitter**

Serial digital signals (either video or audio) are subject to the effects of jitter. This refers to the instantaneous error that can occur from one bit to the next in the exact position each digital transition. Although the signal may be at the correct frequency on average, in the interim it varies. Some bits come slightly early, other come slightly late. The measurement of this jitter is given either as the amount of time uncertainty or as the fraction of a bit width. For 270 Mb/s video, the allowable jitter is 740 picoseconds, or 0.2 UI (Unit Interval – one bit width).

### **Luminance**

The “black & white” content of the image. Human vision had more acuity in luminance, so television systems generally devote more bandwidth to the luminance content. In component systems, the luminance is referred to as Y.

### **Multi-mode**

Multi-mode fibers have a larger diameter core than single mode fibers (either 50 or 62.5 microns compared to 9 microns), and a correspondingly larger aperture. It is much easier to couple light energy into a multi-mode fiber, but internal reflections will cause multiple “modes” of the signal to propagate down the fiber. This will degrade the ability of the fiber to be used over long distances.

See also Single-mode.

## **NTSC**

The color television encoding system used in North America was originally defined by the National Television Standards Committee. This American standard has also been adopted by Canada, Mexico, Japan, Korea, and Taiwan. (This standard is referred to disparagingly as Never Twice Same Color.)

## **Optical**

An optical interface between two devices carries data by modulating a light source. This light source is typically a laser or laser diode (similar to an LED) which is turned on and off at the bitrate of the datastream. The light is carried from one device to another through a glass fiber. The fiber's core acts as a waveguide or lightpipe to carry the light energy from one end to another. Optical transmission has two very significant advantages over metallic copper cables. Firstly, it does not require that the two endpoint devices have any electrical connection to each other. This can be very advantageous in large facilities where problems with ground loops appear. And secondly, and most importantly, an optical interface can carry a signal for many kilometers or miles without any degradation or loss in the recovered signal. Copper is barely useful at distances of just 1000 feet.

## **Oversampling**

A technique to perform digital sampling at a multiple of the required sample rate. This has the advantage of raising the Nyquist Rate (the maximum frequency that can be reproduced by a given sample rate) much higher than the desired passband. This allows more easily realized anti-alias filters.

## **PAL**

During the early days of color television in North America, European broadcasters developed a competing system called Phase Alternation by Line. This slightly more complex system is better able to withstand the differential gain and phase errors that appear in amplifiers and transmission systems. Engineers at the BBC claim that it stands for Perfection At Last.

## **Progressive**

An imaging scanning technique that progresses through all of the lines of a frame in a single pass. Computer monitors all use progressive displays. This contrasts to the Interlace technique common to television systems.

## **Return Loss**

An idealized input or output circuit will exactly match its desired impedance (generally 75 ohms) as a purely resistive element, with no reactive (capacitive or inductive) elements. In the real world, we can only approach the ideal. So, our real inputs and outputs will have some capacitance and inductance. This will create impedance matching errors, especially at higher frequencies. The Return Loss of an input or output measures how much energy is returned (reflected back due to the impedance mismatch.) For digital circuits, a return loss of 15 dB is typical. This means that the energy returned is 15 dB less than the original signal. In analog circuits, a 40 dB figure is expected.



## **RGB**

RGB systems carry the totality of the picture information as independent Red, Green, and Blue signals. Television is an additive color system, where all three components add to produce white. Because the luminance (or detail) information is carried partially in each of the RGB channels, all three must be carried at full bandwidth in order to faithfully reproduce an image.

## **ScH Phase**

Used in composite systems, ScH Phase measures the relative phase between the leading edge of sync on line 1 of field 1 and a continuous subcarrier sinewave. Due to the arithmetic details of both PAL and NTSC, this relationship is not the same at the beginning of each frame. In PAL, the pattern repeats every 4 frames (8 fields) which is also known as the Bruch Blanking sequence. In NTSC, the repeat is every 2 frames (4 fields.) This creates enormous headaches in editing systems and the system timing of analog composite facilities.

## **SDI**

Serial Digital Interface. This term refers to inputs and outputs of devices that support serial digital component video. This generally means standard definition at 270 Mb/s. The use of “HD-SDI” is beginning to appear to indicate High Definition Serial Digital Video at 1.485 Gb/s.

## **SMPTE**

The Society of Motion Picture and Television Engineers is a professional organization which has done tremendous work in setting standards for both the film and television industries. The term “SMPTE” is also shorthand for one particular component video format - luminance and color difference.

## **Single Mode**

A single mode (or mono-mode) optical fiber carries an optical signal on a very small diameter (9 micron) core surrounded with cladding. The small diameter means that no internally reflected lightwaves will be propagated. Thus only the original “mode” of the signal passes down the fiber. A single mode fiber used in an optical SDI system can carry a signal for up to 20 kilometers. Single mode fibers require particular care in their installation due to the extremely small optical aperture that they present at splice and connection points.

See also Multi-mode.

## **TBC**

A Time Base Corrector is a system to reduce the Time Base Error in a signal to acceptable levels. It accomplishes this by using a FIFO (First In, First Out) memory. The incoming video is written into the memory using its own jittery timing. This operation is closely associated with the actual digitization of the analog signal because the varying position of the sync timing must be mimicked by the sampling function of the analog to digital converter. A second timing system, genlocked to a stable reference, is used to read the video back out of the memory. The memory acts as a dynamically adjusting delay to smooth out the imperfections in the original signal’s timing. Very often a TBC will also function as a Frame Synchronizer.

See also: Frame Sync.

### **Time Base Error**

Time base error is present when there is excessive jitter or uncertainty in the line to line output timing of a video signal. This is commonly associated with playback from video tape recorders, and is particularly severe with consumer type heterodyne systems like VHS. Time base error will render a signal unusable for broadcast or editing purposes.

### **Tri Level Sync**

An analog sync reference signal that is used in High Definition systems. Tri Level Sync is constructed with three signal levels, the sync pulses extend above and below a mid-level average voltage (the blanking level). Unlike conventional analog sync which is bi-level, the proper 50% pickoff point is already identified in Tri Level Sync. This contributes to lower jitter in digital systems.

### **YUV**

Strictly speaking, YUV does not apply to component video. The letters refer to the Luminance (Y), and the U and V encoding axes using in the PAL composite system. Since the U axis is very close to the B-Y axis, and the V axis is very close to the R-Y axis, YUV is often used as a sort of shorthand for the more long-winded "Y/R-Y/B-Y".

### **Y/Cr/Cb**

In digital component video, the luminance component is Y, and the two color difference signals are Cr (R-Y) and Cb (B-Y).

### **Y/Pr/Pb**

In analog component video, the image is carried in three components. The luminance is Y, the R-Y color difference signal is Pr, and the B-Y color difference signal is Pb.