

Models 9455 and 7435

Clean and Quiet Protection Switches User Guide



Revision 1.3 SW v1.0.0

ENSEMBLE
DESIGNS

Purveyors of Fine Video Gear—Loved by Engineers Worldwide

Clearly, Ensemble wants to be in the broadcast equipment business. It's so rare anymore to find a company of this caliber that has not been gobbled up by a large corporation. They are privately held so they don't have to please the money people. They really put their efforts into building products and working with customers.

I'm really happy with the Avenue products and Ensemble's service, and even more important my engineers are happy. We've continued to upgrade the product and add more cards. We will be rebuilding our production control room and we will use Avenue again.

~ Don McKay, Vice President Engineering, Oregon Public Broadcasting

Who is Ensemble Designs?

By Engineers, For Engineers

In 1989, a former television station engineer who loved designing and building video equipment, decided to start a new company. He relished the idea of taking an existing group of equipment and adding a few special pieces in order to create an even more elegant ensemble. So, he designed and built his first product and the company was born.



Avenue frames handle 270 Mb/s, 1.5 Gb/s and 3 Gb/s signals, audio and MPEG signals. Used worldwide in broadcast, mobile, production, and post.

Focused On What You Need

As the company has grown, more former TV station engineers have joined Ensemble Designs and this wealth of practical experience fuels the company's innovation. Everyone at the company is focused on providing the very equipment you need to complete your ensemble of video and audio gear. We offer those special pieces that tie everything together so that when combined, the whole ensemble is exactly what you need.

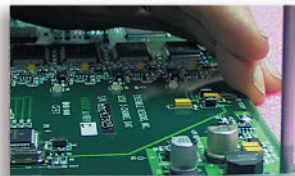

We're focused on processing gear—3G/HD/SD/ASI video, audio and optical modules.

Notably Great Service for You

We listen to you – just tell us what you need and we'll do our best to build it. We are completely focused on you and the equipment you need. Being privately held means we don't have to worry about a big board of directors or anything else that might take attention away from real business. And, you can be sure that when you call a real person will answer the phone. We love this business and we're here to stay.



Come on by and visit us. Drop in for lunch and a tour!

Bricks and Mortar of Your Facility

The bricks and mortar of a facility include pieces like up/downconverters, audio embedders, video converters, routers, protection switches and SPGs for SD, HD and 3Gb/s. That's what we're focused on, that's all we do – we make proven and reliable signal processing and infrastructure gear for broadcasters worldwide, for you.



Shipped with care to television broadcasters and video facilities all over the world.



Contents

Module Overview	5
SDI Signal Evaluation	6
Applications	9
Auto-Switched Upconversion Application	9
Fiber Feed Application	9
Front and Rear Lexans	10
Backplane Diagram	11
7435 and 9455 Parameter Table	13
Front Panel Controls and Indicators	15
Avenue PC and Touch Screen Remote Configuration	16
Getting Started	17
<i>Output Menu</i>	17
<i>Status Menu</i>	19
<i>Config Menu</i>	21
<i>Blk Detect Menu</i>	23
<i>Aud Detect Menu</i>	25
<i>Freeze Menu</i>	27
<i>General Purpose Interface: GPI/GPO</i>	29
<i>23700048 Interface Adapter Cable Drawing and Pinouts</i>	30
<i>GPI Menu</i>	31
<i>GPI Output Jumpers</i>	33
<i>Reference Menu</i>	35
<i>Timing Menu</i>	37
<i>Pri Errors Menu</i>	39
<i>Sec Errors Menu</i>	40
<i>Inputs Menu</i>	41
<i>Memory Menu</i>	43
Software Updates	44
Step by Step Overview for Updating Software in your 9455 or 7435:	45
Detailed Instructions for Updating Software in your 9455 or 7435:	46
<i>IP Adr Menu</i>	46
<i>Subnet Menu</i>	48

Troubleshooting	52
Warranty and Factory Service	53
Specifications	54
Glossary	55

Module Overview

The 9455 and 7435 modules are clean and quiet protection switches for critical broadcast and satellite feeds. They switch cleanly between asynchronous sources which means they can be used live to air. Each module has a full video frame synchronizer, rather than a line delay, ensuring perfect alignment of mis-timed and non-synchronous SDI sources. The 7435 supports 1.5 Gb/s HD SDI and SD SDI signals. The 9455 additionally supports 3 Gb/s HD SDI.

When a fault is detected in the primary input, and the secondary input is verified as good, the switch will activate, causing the secondary input to be switched cleanly and quietly to the module's output. The 9455 and 7435 include fail-safe bypass which connects the primary input directly to one module output. This passive, fail-safe path ensures that there is an output even in the event of a total power failure.

Clean and quiet switching between sources requires that the sources be synchronous and precisely timed to each other. The 9455 and 7435 accomplish this automatically, with integral frame synchronization of the inputs, allowing operation with both synchronous and asynchronous (wild) sources. This frame synchronization feature not only means that the output will always be stable and glitch-free, but it also means that in the event of a total loss of both inputs, consistently timed color black will still be output.

The internal frame synchronizers can be genlocked to an external reference signal so that the output of the 9455 or 7435 is synchronous to local sources. Alternately, in teleports, headends, and other multi-service facilities, where there is no logical common reference, the module will internally generate an accurate reference.

The delay through the 9455 or 7435 can be adjusted up to six frames, with independent control for the primary and secondary input paths. By operating with several frames of delay, the fault detection algorithms are given enough time to detect a failure in an input signal and switch to the backup before the fault has actually appeared on-air.

Different types of signal testing (vetting) can be enabled on the module. This happens automatically and independently for the primary and secondary inputs. The health of the video signal is determined by monitoring crucial parameters in order of increasing complexity; Timing Reference Signal (TRS), or a persistent loss of digital sync is tested first. Black, Embedded Audio and Freeze are also evaluated. Each test can be configured by the user. For example, the sophisticated Black Detector includes configurable parameters for black level threshold, pixel count, and duration time.

The Freeze detection system can be set to detect a clean or noisy source. Freeze Time sets the number of seconds for the 9455 or 7435 to switch to the secondary input after a video freeze condition is detected in the primary input.

The switch can operate in two modes: automatic or nonresetting. In fully automatic mode, the module will automatically switch back to the primary signal once it's been restored. In the nonresetting mode, the secondary input remains routed to the output, even after the primary input has recovered. In this case manually switching back to the primary is required. If no valid input can be found, consistently timed color black will be output.

Controls are easily accessed through an Avenue Control Panel, Avenue PC software, GPIs, or front edge module controls. Software updates for the module are done through a web browser via Ethernet using the Interface Adapter Cable that comes with the module. This cable provides an Ethernet connection

for software upgrades and a 9-pin GPI/GPO connector for control. GPI inputs allow faults detected in upstream equipment to contribute to the switching logic.

Avenue module parameters can be configured and controlled remotely from one or both of the remote control options, the Avenue Touch Screen or the Avenue PC Application. Once the module parameters have been set remotely, the information is stored on the module CPU. This allows the module be moved to a different slot in the frame at your discretion without losing the stored information.

SDI Signal Evaluation

The 9455/7435 monitors the integrity of the serial digital input stream and analyzes its audio and video content. HD SDI signal health and fault detection is determined by monitoring any or all of the following parameters, in order of increasing complexity:

- **Timing Reference Signal (TRS)** – This parameter checks for the persistent loss of digital sync by looking for the correct Timing Reference Signal carried in the serial video stream. When this digital sync format is correct, the signal is considered good.
- **Black** – Black detection is based on three configurable parameters: black level threshold, black pixel count, and black duration time. All of these parameters can be set using the menu system to meet the needs of specific video signal inputs.
- **Embedded Audio** – This parameter will look for correctly configured embedded audio packets in the horizontal intervals of the signals. The actual audio content of the packets is further analyzed to detect silence. Specific audio parameters, such as audio group, silence threshold level, and audio silence duration can be configured in the Avenue PC and Touch Screen menus.
- **Freeze** – This parameter checks for a freeze condition as determined by the settings selected in the Freeze menu.

A sophisticated black detection system is employed to activate the switch in the event that the signal is lost. It allows the user to select not only the threshold and percentage of black pixels, but also the portion of the picture to be considered. The area of the picture checked is determined by selecting **Small Window** which is approximately two thirds of the picture width and height, or **Big Window** which covers approximately 90% of the width and height. This allows a corner Bug to be either excluded or included in the detection process.

Black detection is performed on a pixel-by-pixel basis within the selected window, with user selectable **Detect Level** and **Blk Frac** adjustments. Pixels above the **Detect Level** are considered to be non-black. **Blk Frac** sets the percentage of pixels which must be black in order to trigger an error. For example, if **Detect Level** is set to 12 IRE and **Blk Frac** is set to 90%, and **Blk Time** is set to 3 seconds, then if more than 90% of the pixels in each frame are below the selected 12 IRE level for a period of 3 seconds, a switch will occur.

Pri Valid and **Sec Valid** are dynamic values based on incoming video. In the above example, if **Pri Valid** fell below **Blk Frac** continuously for 3 seconds there would be a switch, provided that there is valid secondary video. Note however, that the display may not keep pace with short duration transitions of actual video. In the example, an excursion above 12 IRE for a single frame every 2 seconds would not cause a switch to take place, since the 3 second count would be reinitialized by these valid frames.

9455 Clean and Quiet Protection Switch Block Diagram

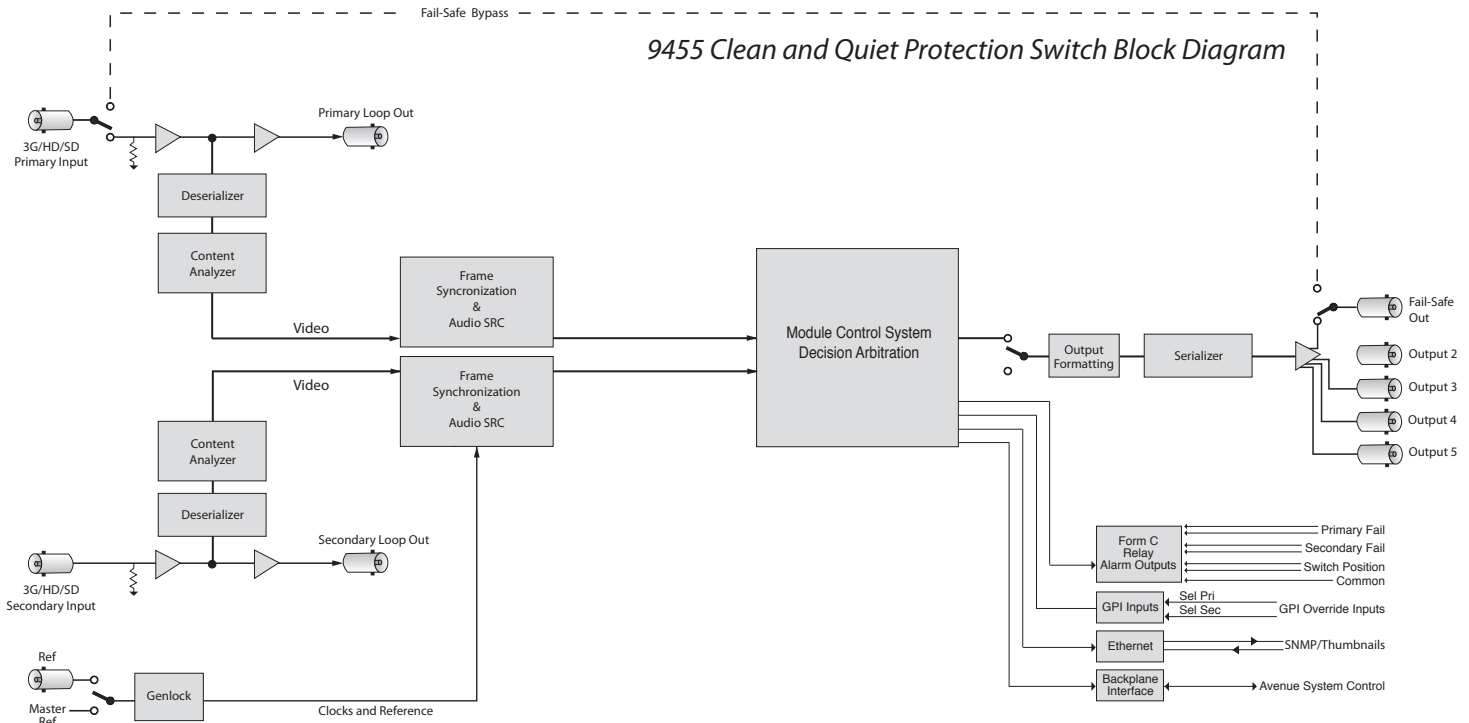

The block diagram, above and on the following page, illustrates the signal flow of the 9455. Note that in the event of power failure, the passive relay passes the primary input to the Relay Protected Output.

The Primary and Secondary inputs pass through serial digital receiver/equalizers for buffering. When a fault is detected in the Primary input, and the Secondary input is seen as not faulted, the electronic solid state switch will activate, switching the Secondary input to the output. If both the primary and the secondary inputs signals are faulted, consistently timed color black will be output.

Each of the signals is fed to identical detection circuits which evaluate multiple parameters and characteristics of the signal in order to arrive at a fault decision. The output feeds a Field Programmable Gate Array (FPGA) where the signals are vetted, or tested for configured parameters. The Signal Vetter™ process in the FPGA detects the parameters chosen by the user through the Avenue PC or Touch Screen menus. Each of the chosen aspects are monitored independently, and when they fail to meet the vetted standard, a fault condition is issued.

Fault conditions can be monitored with an external alarm system or other device through the 9-pin **Control** connector of the dongle connected to the corresponding 15-pin rear backplane connector. The Form C relays status outputs from this connector can be monitored by a device to show Primary and Secondary signal status and the current position of the protect switch (Primary or Secondary).

Two GPI Override Inputs are available to allow changing switch position in response to triggers from an external source. This can be used to manually reset the switch after the Primary has recovered from a fault condition or set to respond to a signal state from an external device to trigger a switch.

The on-board CPU can monitor and report module ID information (slot location, software version and board revision), and power status to the frame System Control module. This information can be accessed by the user or set to register an alarm if desired using the remote control options available.

Every function and parameter on the module can be controlled from an Avenue Touch Screen Control Panel or the Avenue PC Control Application. Memory registers can be used to save the complete configuration of the module, making it easy to change instantly between different configurations.

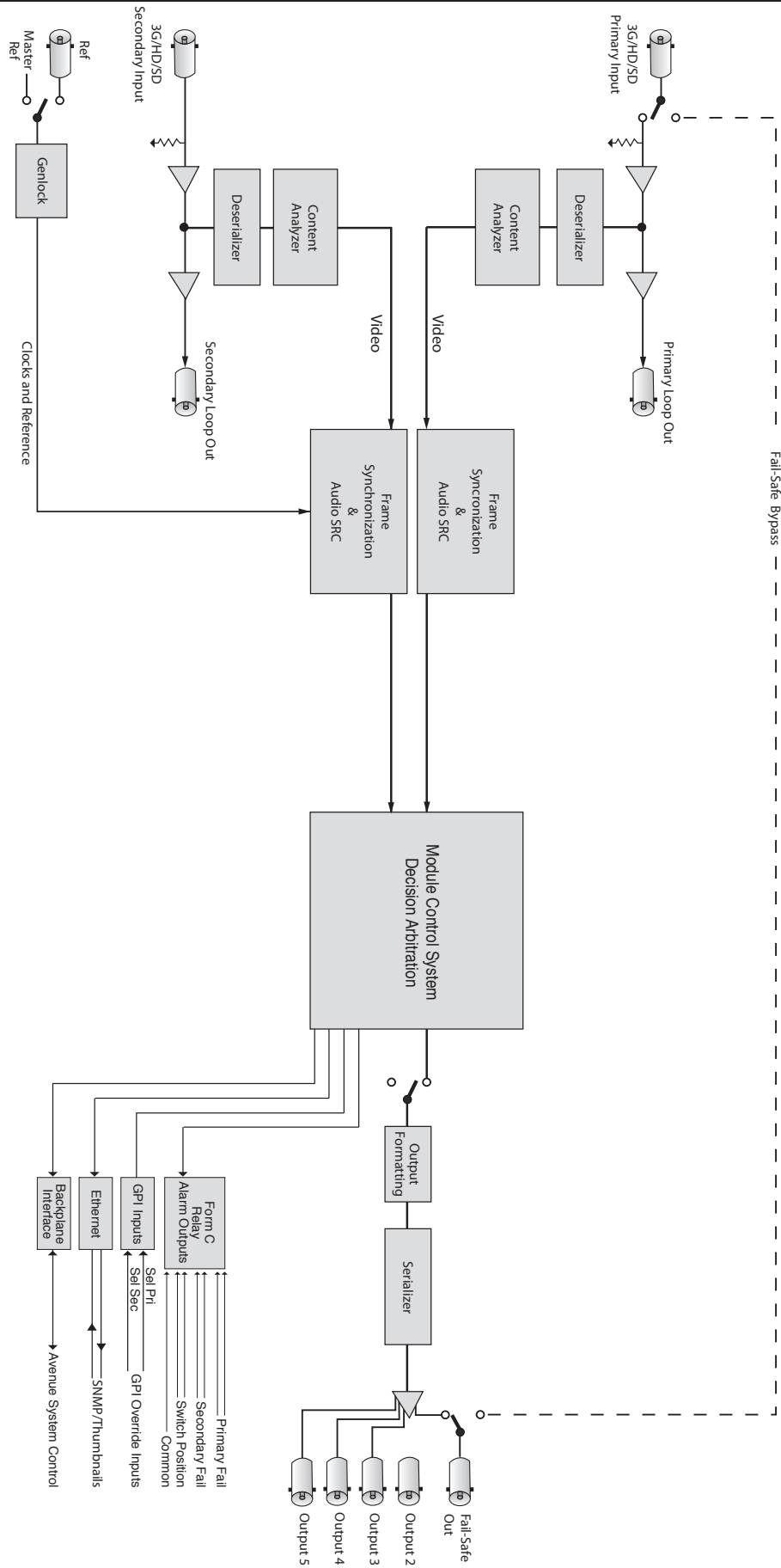

9455 Clean and Quiet Protection Switch Block Diagram, landscape view

Note: 7435 does not support 3G but is otherwise identical to the 9455

Applications

Auto-Switched Upconversion Application

The diagram below shows a typical use for the 7435 module, where it is used to form a fully redundant, auto-switched conversion chain. The Primary input is backed up with a Secondary input from a video server. When a switch occurs, the output is always clean switched.

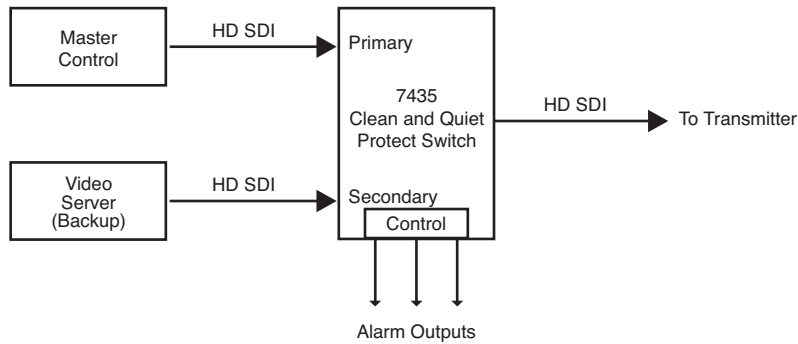

Redundant Auto-Switched Conversion with 7435 Module

The 7435 Clean and Quiet Protection Switch accepts HD SDI or SD SDI inputs. For 3G signals, choose the 9455 Clean and Quiet Protection Switch.

Relay circuits accessible from the 9-pin D Control connector can be connected to alarms for monitoring Primary and Secondary status and switch position.

Fiber Feed Application

In the example below, a fiber feed goes to an Avenue 3720 optical-to-electrical converter and into the 9455. The 9455 evaluates the 3Gb/s HD SDI signal health of both feeds and cleanly switches to the secondary feed if required.

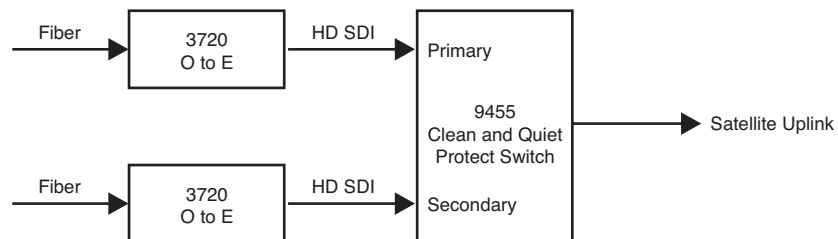

Fiber Feed with 9455 Module

Front and Rear Lexans

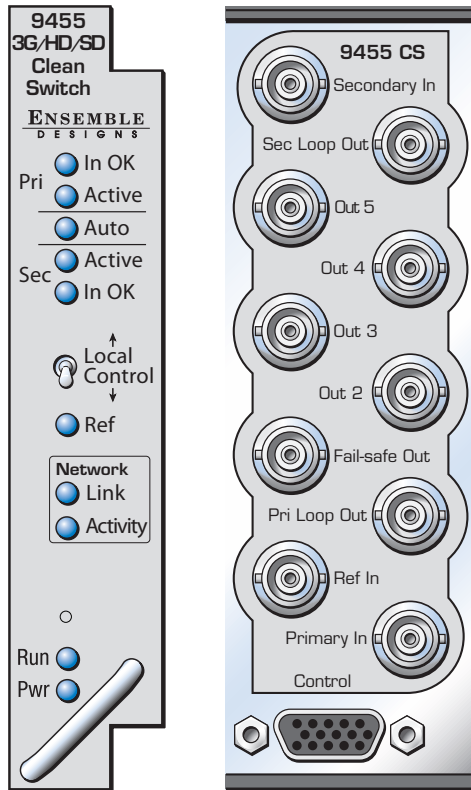

9455 Lexans: front, 3RU rear and 1RU rear

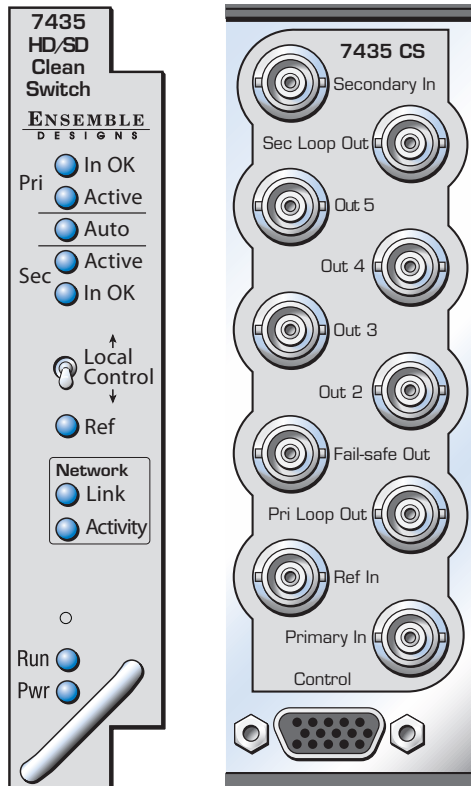
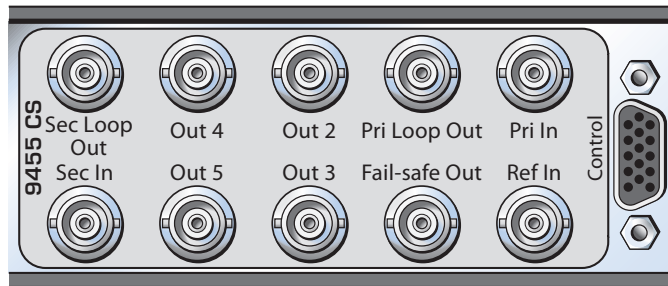

7435 Lexans: front, 3RU rear and 1RU rear

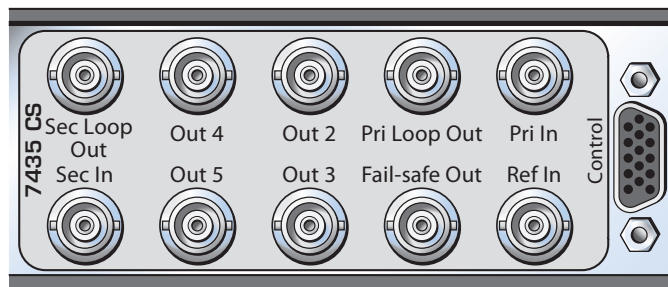

Backplane Diagram

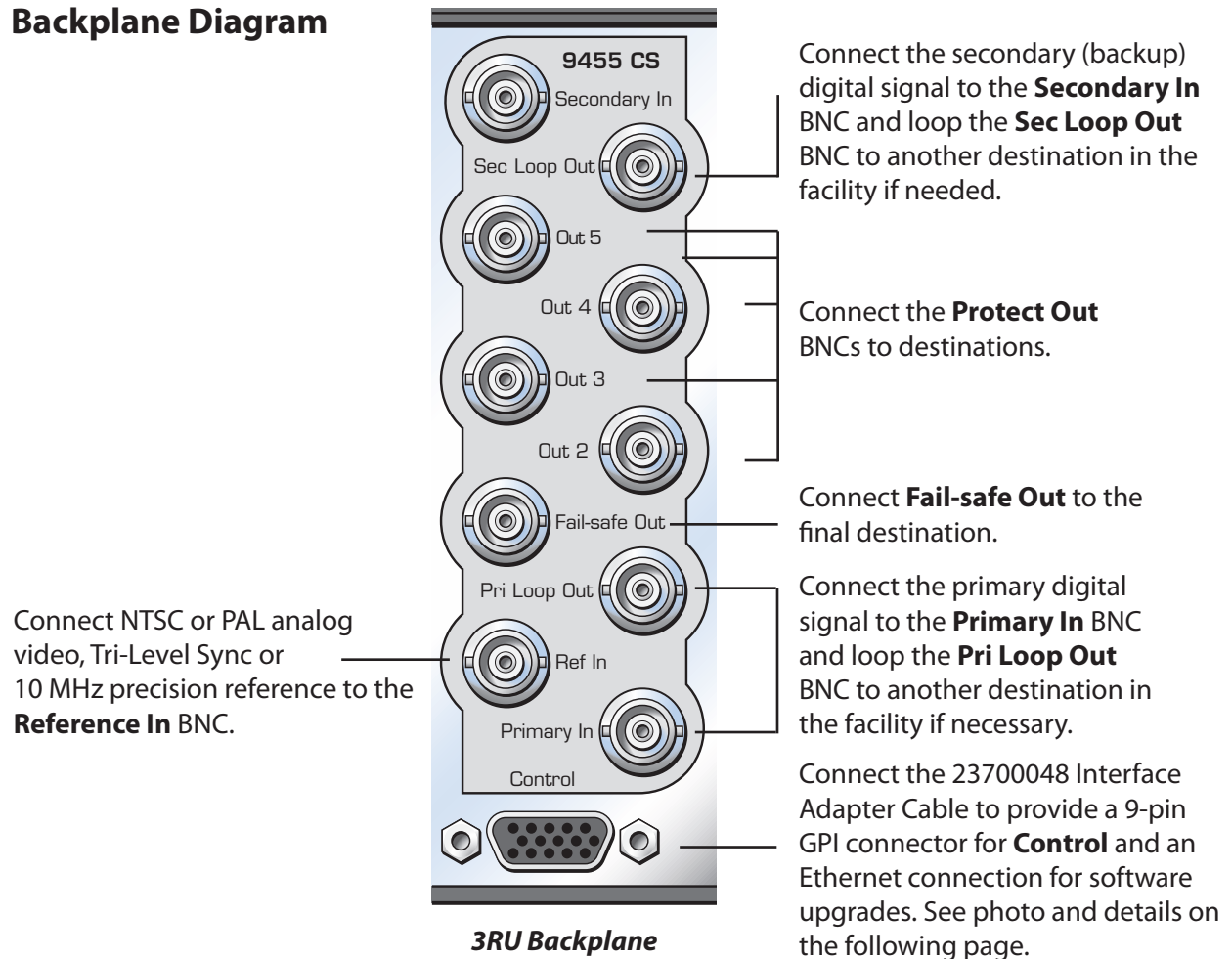

23700048 Interface Adapter Cable

The 23700048 Interface Adapter Cable cable connects to the 15 pin D connector on the back of the Avenue frame that is associated with the clean switch module. The Ethernet port is used for software upgrades and the 9 pin D connector is used for GPI control.

Software updates are done with a web browser through the Ethernet connection, not thorough Avenue PC. Please see the "Step by Step Overview for Updating Software in your 9455 or 7435:" on page 45 for more details.

Please refer to "GPI Menu" on page 31 , and subsequent pages on GPI/GPO for more detailed information regarding external control.

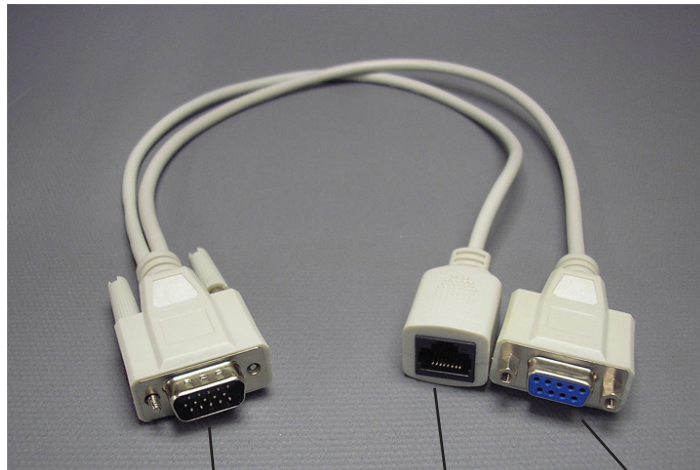

Connect the male 15 pin D connector to the female 15 pin D connector on the back of the frame that corresponds to the clean switch module

Ethernet for software upgrades

9 pin female D connector for control. Pinouts and details are in the GPI section of this manual beginning on page 28.

7435 and 9455 Parameter Table

CONTROL	AVENUE PC or TOUCH SCREEN	DEFAULT
Auto Reset	On Off	On
Reset Time	0 - 120 seconds	15 seconds
TRS Test	Off Lenient Strict	Lenient
Audio Detect	On Off	Off
Black Detect	On Off	On
Freeze Test	Off	On
Sec Test Enable	On Off	On
Window	Small Big	Big
Black Time	0.1 - 300 sec	3 sec
Detect Level	0 - 100 IRE	10 IRE
Black Fraction	0 - 100%	95%
Audio Group	Group 1 Group 2 Group 3 Group 4	Group 1
Group Detect	Detect Off	Detect
Audio Threshold	0VU -5 VU -10 VU -15 VU -20 VU -25 VU -30 VU -35 VU -40 VU	-20 VU
Audio Time	.5 - 300 sec	3 sec
Audio Channel enable	Ch1 enable/disable Ch2 enable/disable Ch3 enable/disable Ch4 enable/disable Ch5 enable/disable Ch6 enable/disable Ch7 enable/disable Ch8 enable/disable Ch9 enable/disable Ch10 enable/disable Ch11 enable/disable Ch12 enable/disable	Enabled Enabled Disabled Disabled Disabled Disabled Disabled Disabled Disabled Disabled Disabled Disabled

CONTROL	AVENUE PC or TOUCH SCREEN	DEFAULT
Audio Channel enable (continued)	Ch13 enable/disable Ch14 enable/disable Ch15 enable/disable Ch16 enable/disable	Disabled Disabled Disabled Disabled
Freeze Time	0.1 - 300 sec	3 sec
PRI GPI Mode	Off Neg Edge Switch Neg Edge Reg 1	Off
Sec GPI Mode	Off Neg Edge Switch Neg Edge Reg 2	Off
Reference Source	Master Ref External	Master Ref
Frame Delay 1	0 - 6 frames	1
Frame Delay 2	0 - 6 frames	1
Vert Timing	-1000 to 1000 lines	0
Hor Timing	-1000 to 1000 clocks	0
Output Std	720p/50 720p/59.94 720p/60 1080i/50 1080i/59.94 1080i/60 1080p/25 1080p/23.98 1080p/24 3G 1080p/50 3G 1080p/59.94 3G 1080p/60 1080sF/25 1080sF/23.98 1080sF/24 SD525 SD625	1080i/59.94
IP Address	Assignable	192.168.1.100
Sunbnet Mask	Assignable	255.255.255.0
Memory Registers	1 - 5	Last Saved

Front Panel Controls and Indicators

Each front edge indicator and switch setting of the 9455 is shown in the diagram below:

Pri In OK green LED:

ON when Primary input passes all enabled tests.
OFF when Primary input fails an enabled test.

Pri Active green LED:

ON when Primary input is feeding the output.
OFF when Primary input is not feeding the output.
BLINKING when no valid input is found. The module will output timed black. Note that the Secondary Active LED will also be blinking.

Local Control Switch:

Four position switch used to turn Auto function **ON** or **OFF**, and to set output to Primary or Secondary.

Run green LED:

OFF A power fault or halted CPU
ON A halted CPU
FAST BLINK CPU Run error
SLOW BLINK System OK. (If SPI control is active from the main frame System Control Module, all Run indicators will be synchronized.)

Pwr green LED:

Indicates the presence (**ON**) or absence (**OFF**) of power.

Auto green LED:

ON when Auto is active.
OFF when Auto is turned off.

Sec Active red LED:

ON when Secondary input is feeding the output.
OFF when Secondary input is not feeding the output.
BLINKING when no valid input is found. The module will output timed black. Note that the Primary Active LED will also be blinking.

Sec In OK green LED:

ON when Secondary input passes all enabled tests.
OFF when Secondary input fails an enabled test.

Ref green LED:

ON when locked to a valid external reference.
OFF when no external reference is detected.

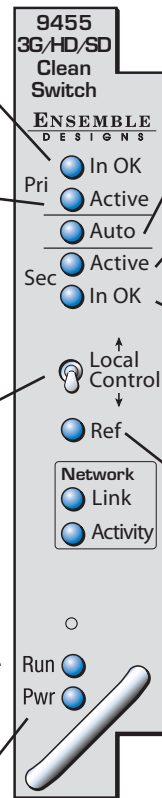

Avenue PC and Touch Screen Remote Configuration

The Avenue PC and Touch Screen remote control status menus for the 9455 and 7435 modules are illustrated and explained in the following section. Refer to the **9455 and 7435 Parameter Table** for a summary of available parameters that can be set remotely through the menus illustrated. For more information on using Avenue PC, refer to the Avenue PC Control Application Software data pack that came with the option. For more information on using Avenue Touch Screen, refer to the Avenue Touch Screen data pack.

Parameter fields that are grayed out can indicate one of the following conditions:

- An option is not installed.
- The function is not active.
- The module is locked.
- The User Level set with Avenue PC is not accessible from the current User Level.

Getting Started

Output Menu

The first step setting up your clean protection switch is to assign the output standard to the module in the **Output** menu. The **Output** menu screen shown on the following page allows you to select your output standard, and to enable or disable embedded audio in all four audio Groups.

- **Output Std** – select the output standard from the following:
 - 720p/50
 - 720p/59.94
 - 720p/60
 - 1080i/50
 - 1080i/59.94
 - 1080i/60
 - 1080p/25
 - 1080p/23.98
 - 1080p/24
 - 3G 1080p/50
 - 3G 1080p/59.94
 - 3G 1080p/60
 - 1080sF/25
 - 1080sF/23.98
 - 1080sF/24
 - SD525
 - SD625

The default setting is 1080i/59.94

Note that the output standard selected in this menu must match the input standard of both the Primary and Secondary inputs. If the output standard does not match the inputs, the module will output timed black. This will be indicated in the **Switch Position** reporting window of the **Status Menu**. Additionally, on the front panel of the module the Primary Active and Secondary Active LEDs will blink simultaneously.

- **Embed Grp 1, Embed Grp 2, Embed Grp 3, Embed Grp 4** – the default setting and standard operation for Embed Groups 1 through 4 is enabled. Disable only if you want to strip audio from the output. When disabled an audio fault will trigger and be indicated in the status menu.

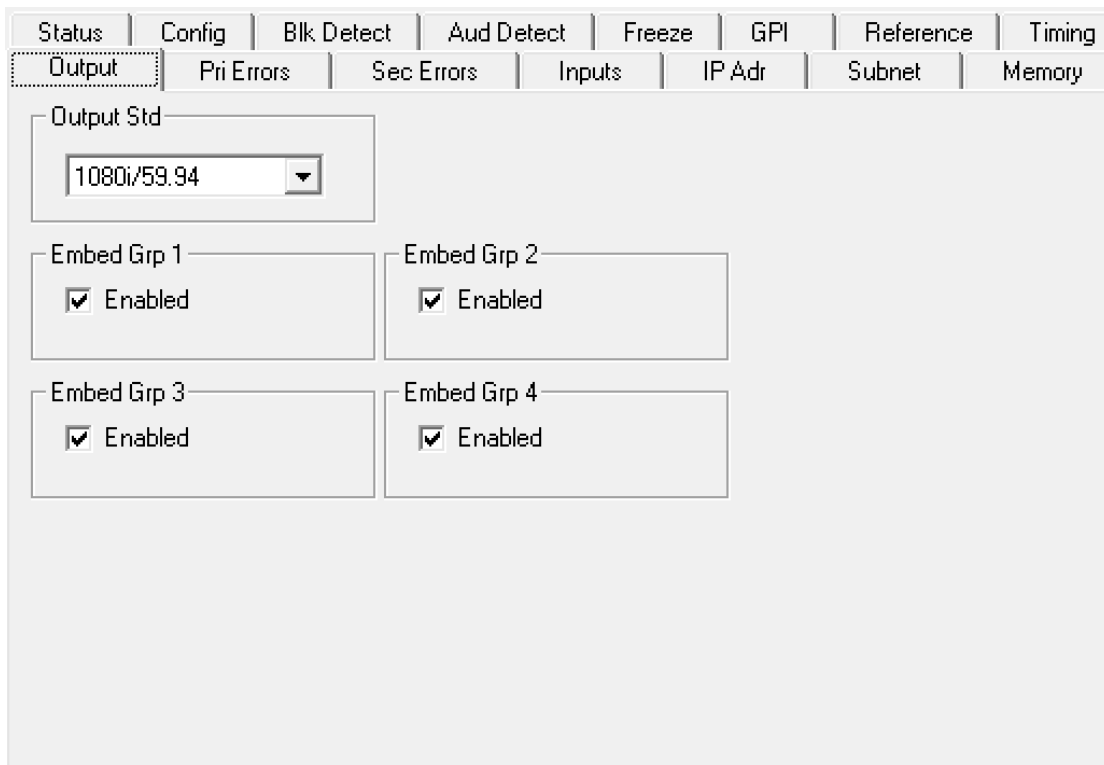

Output Avenue PC Menu

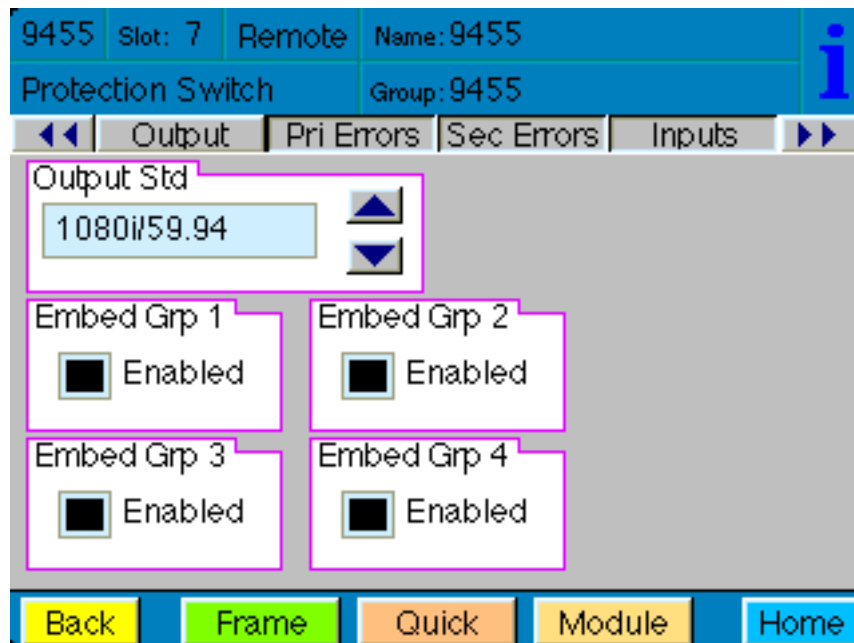

Output Touch Screen Menu

Status Menu

The **Status** menu screen shown on the following page displays overall status of selected parameters on both the Primary and Secondary inputs as Green = Good, Red = Bad, Gray = Not enabled. It allows you to enable or disable the **Auto Reset** control and to set the **Reset Time** for the switching function. In Avenue PC, additional reports are provided for Primary Status and Secondary Status. These two reports do not appear on the Avenue Touch Screen.

- **Pri Status** – shows the status of the Primary input's Timing Reference Signal (**TRS**), embedded audio present and correct (**Aud**), black detected as defined in the **Black Detect** menu (**Blk**), and if frozen video is detected as defined in the **Freeze** menu (**Frz**).

In Avenue PC only, the additional **Pri Status** reporting window to the right will display the status of the Primary as **Signal Good** or **Signal Fault**, and can be monitored with the Avenue PC alarm function.

- **Sec Status** – shows the status of the Secondary input's Timing Reference Signal (**TRS**), embedded audio present and correct as defined on the **Aud Detect** menu (**Aud**), and black detected as defined in the **Blk Detect** menu (**Blk**), and if frozen video is detected as defined in the **Freeze** menu (**Frz**).

In Avenue PC only, the additional **Sec Status** reporting window to the right will display the status of the Secondary as **Signal Good** or **Signal Fault**, and can be monitored with the Avenue PC alarm function.

- **Switch Pos** – the status window will indicate the current position of the protect switch as **Primary**, **Secondary** or **Internal Black**. This window can be monitored by the Avenue PC alarm function.
- **Pri** – lights green when the Primary input is selected to the output. Click this control to select the Primary as the output.
- **Auto** – lights green when **Auto** is turned on. Switch **Auto** on and off with this control. When **Auto** is on, the module will automatically switch to the Secondary input if the Primary fails and the Secondary is good.

Note: If the module cannot find a good signal on the Primary or the Secondary, it will output consistently timed black. In this situation, both the Primary and Secondary buttons will be grey and the **Switch Position** window will report **Int Blk**. The most likely cause of this is an incorrectly set Output Format. The Output Format is set in the **Output Menu** and must match the format of the Primary and Secondary inputs. The Input Formats are auto detected and show in the Primary and Secondary Input report windows in the **Input Menu**.

- **Sec** – lights red when the Secondary input is selected to the output. Click this control to select the Secondary as the output.
- **Auto Reset** – set to **On** or **Off** to determine if the switch will automatically switch back to the Primary after it recovers.
- **Reset Time** – set the amount of time the Primary signal must be good before the **Auto Reset** switches back to Primary from Secondary.

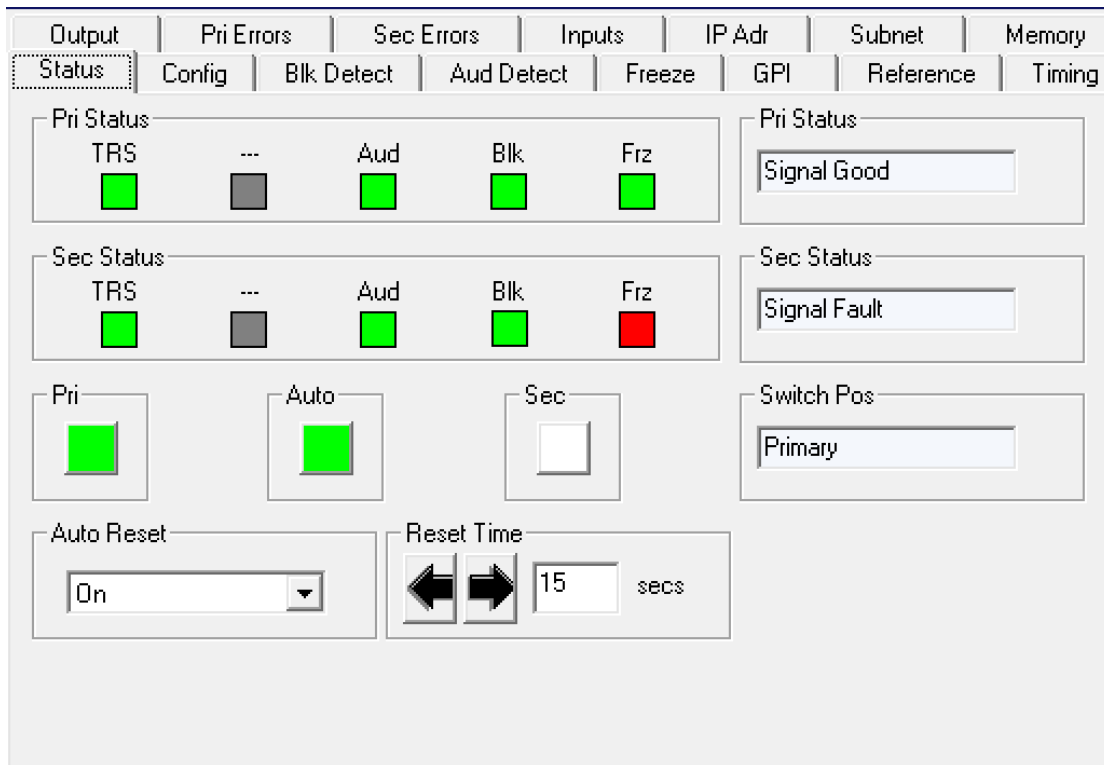

Status Avenue PC Menu

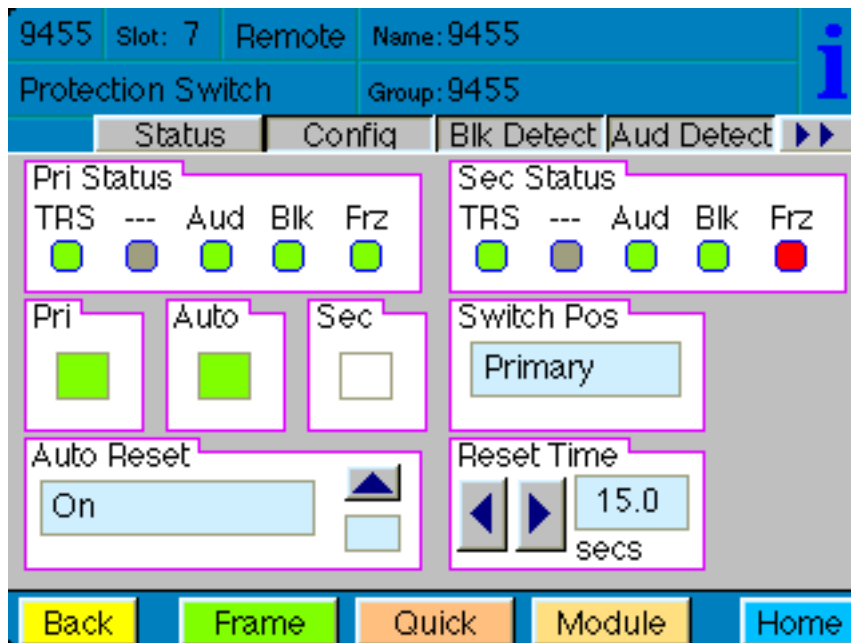

Status Touch Screen Menu

Config Menu

The **Config** menu shown on the following page allows you to configure the TRS Test, and enable or disable the Audio Detect, Black Detect, Freeze Detect and Secondary Test Enable controls. When the Audio Detect, Black Detect and/or Freeze Detect are enabled, use their specific menus to set detailed parameters for each.

- **TRS Test** – enables the test for any Timing Reference Signal (TRS) errors.

Off – sets the input for no TRS test.

Lenient – allows occasional TRS errors to be ignored (10 frames in a row).

Strict – detects any TRS error as a fault.

Default setting is Lenient.

- **Audio Detect** – enables the test for embedded audio. Use the **Aud Detect** menu to set the specific parameters for embedded audio detection.

On – detects an audio condition as determined by the settings made in the **Aud Detect** menu.

Off – sets the input for no audio test.

Default setting is Off.

- **Black Detect** – enables the test for black detection. Use the **Blk Detect** menu to set the specific parameters for black detection.

On – detects black present as defined by the settings made in the **Blk Detect** menu.

Off – sets the input for no black test.

Default setting is On.

- **Freeze Test** – enables the test for a freeze condition. Use the **Freeze** menu to set the specific parameters for freeze detection.

On – detects an audio condition as determined by the settings made in the **Freeze** menu.

Off – Set to **Off** for no freeze test.

Default setting is On.

- **Sec Test Enable** – enables the test for checking the status of the Secondary input.

On – the Secondary status will be checked for the same configuration tests as assigned for the Primary. **On** is the recommended setting.

Off – no vetting will be performed on the Secondary input.

Default setting is On.

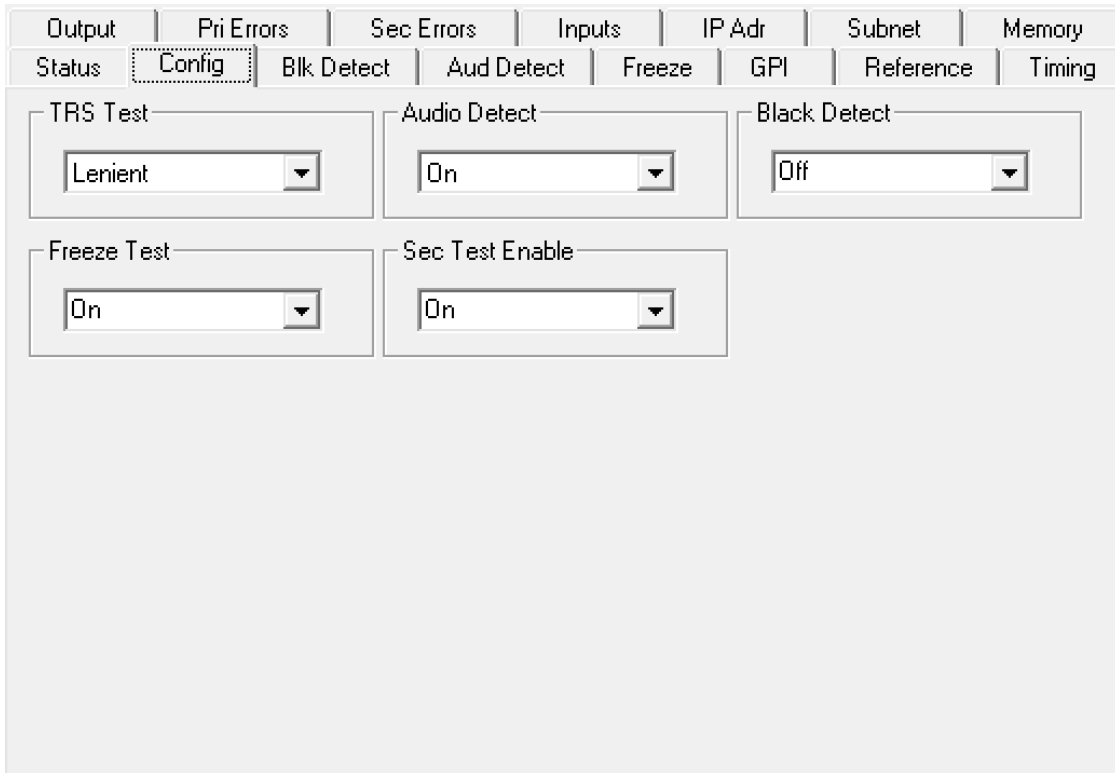

Config Avenue PC Menu

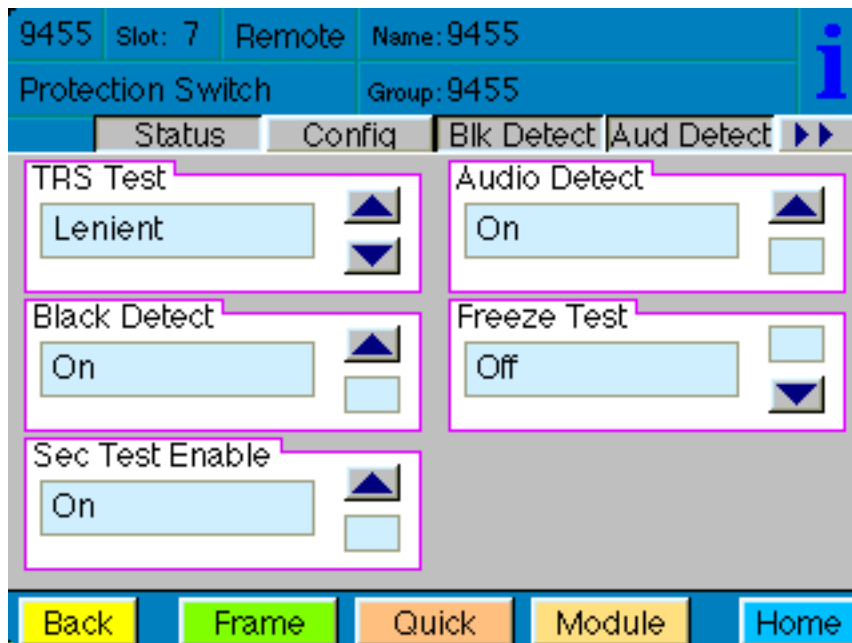

Config Touch Screen Menu

Blk Detect Menu

The **Blk Detect** menu shown on the following page allows you to configure the black detect parameters. Select the threshold and percentage of black pixels, the portion of the picture to be considered, and the amount of time that the signal will be evaluated before a fault is generated.

- **Window** – select **Big** or **Small**. This allows a corner Bug to be either excluded or included in the detection process.

Big – examines nearly the entire raster, approximately 90% of the width and height.

Small – limits the test to a smaller portion of the raster, approximately two thirds of the picture width and height (somewhat smaller than Safe Title limits).

Default setting is Big.

- **Blk Time** – select the amount of time from one frame to 300 seconds that the signal must be continuously in black before the module switches and alarm is generated.

Default setting is 3 seconds.

- **Detect Level** – set the video value from 0 to 100 IRE, below which a pixel is considered to be black.

Default setting is 10 IRE.

- **Blk Frac** – set the percentage of pixels within the detection window that must be black (as defined by **Detect Level** IRE setting) in order to trigger a fault.

Default setting is 95%.

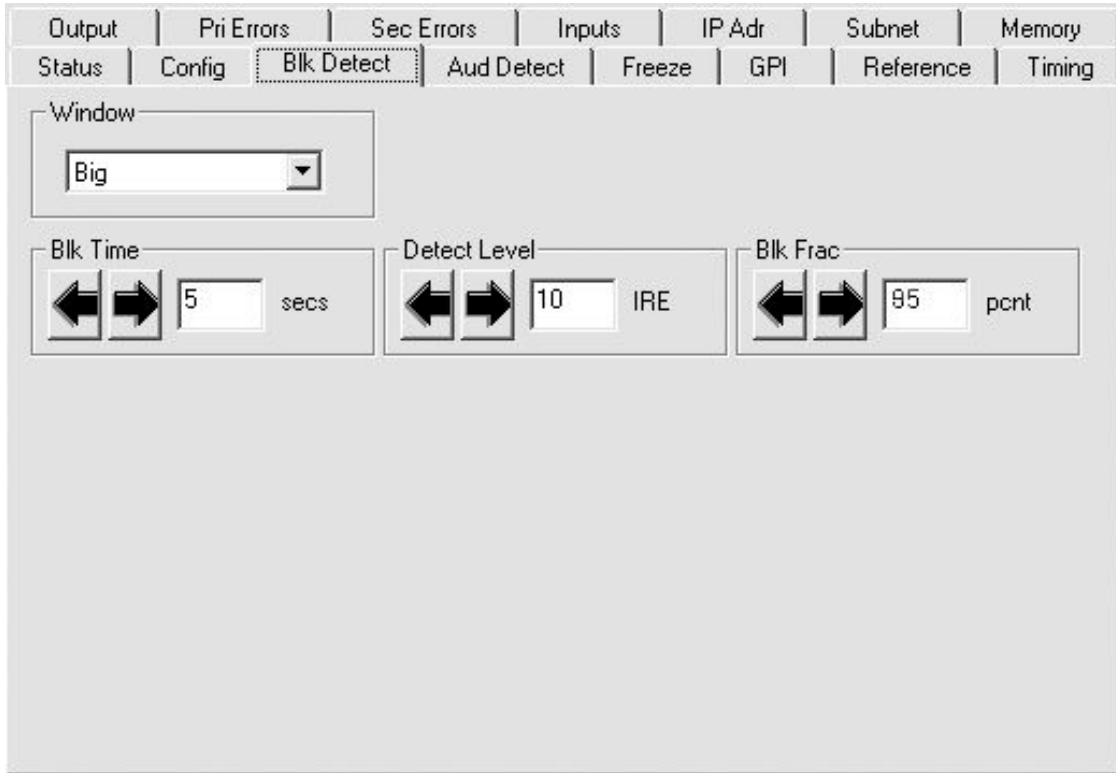

Blk Detect Avenue PC Menu

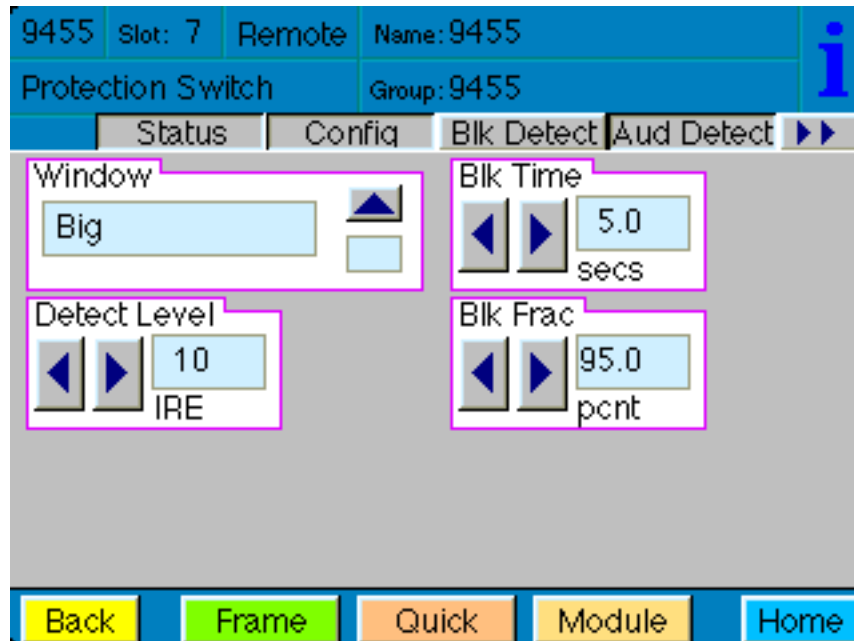

Blk Detect Touch Screen Menu

Aud Detect Menu

The **Aud Detect** menu shown on the following page allows you to configure which groups and channels are monitored for embedded audio presence, to set the VU levels, to set the silence time before an alarm is triggered, and to monitor audio status.

The **Group Select**, **Group Detect** and **Ch1, Ch2, Ch3, Ch4** controls work together as follows:

- **Group Select** – this pull down allows you to select Group 1, Group 2, Group 3 or Group 4. Then use the **Group Detect** control and the **Ch1, Ch2, Ch3, Ch4** enable/disable buttons to define how you would like the selected group monitored, as described below.
- **Group Detect**– select **Detect** or **Off** individually for each of the four embedded audio groups (Group 1, Group 2, Group 3, Group 4).
- **Ch1, Ch2, Ch3, Ch4** – enable or disable monitoring of all 16 audio channels as follows:

When **Group 1** is selected in the **Group Select** control, the **Ch1, Ch2, Ch3, Ch4** enable/disable buttons represent Channels **1, 2, 3** and **4**.

When **Group 2** is selected in the **Group Select** control, the **Ch1, Ch2, Ch3, Ch4** enable/disable buttons represent Channels **5, 6, 7** and **8**.

When **Group 3** is selected in the **Group Select** control, the **Ch1, Ch2, Ch3, Ch4** enable/disable buttons represent Channels **9, 10, 11** and **12**.

When **Group 4** is selected in the **Group Select** control, the **Ch1, Ch2, Ch3, Ch4** enable/disable buttons represent Channels **13, 14, 15** and **16**.

Each embedded group contains four audio channels. Sensing for each channel can be enabled separately.

- **Aud Thrsh** – select the silence detection level from 0 VU to -40 VU in 5 VU increments.

Note: An audio signal level of 0 VU corresponds to -20 dBFS and is the generally accepted digital reference level for AES audio. The 9455 and 7435 use the standard weighting and ballistics of VU (Volume Unit) measurement rather than decibel-based measurement in order to more closely represent audio levels as perceived by the listener.

- **Audio Time** – set the time that the channels must be continuously silent before an alarm is triggered (0 – 20 seconds). Note that a loss of embedded audio will cause an immediate switch, regardless of this setting.

The following status displays are also provided:

- **Pri Status** – shows the status of the four audio channels (of the currently selected Group) embedded in the Primary signal. Green indicates Channel OK, red indicates silence, and gray indicates channel not enabled. An **OK** indicator shows the overall result of the test for all the channels enabled.

- **Sec Status** – shows the status of the four audio channels (of the currently selected Group) embedded in the Secondary signal. Green indicates Channel OK, red indicates silence, and gray indicates channel not enabled. An **OK** indicator shows the overall result of the test for all the channels enabled.
- **Pri Aud Status** – shows the overall status of the audio channels embedded in the Primary signal. This window can be monitored by the Avenue PC alarm function.
- **Sec Aud Status** – shows the overall status of the audio channels embedded in the Secondary signal. This window can be monitored by the Avenue PC alarm function.

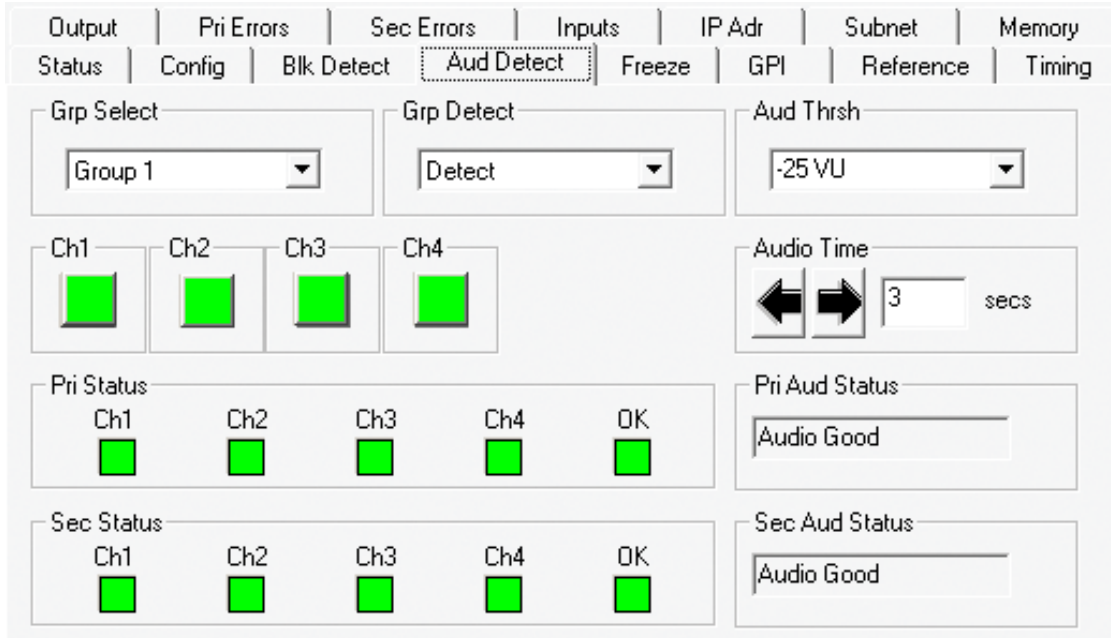

Aud Detect Avenue PC Menu

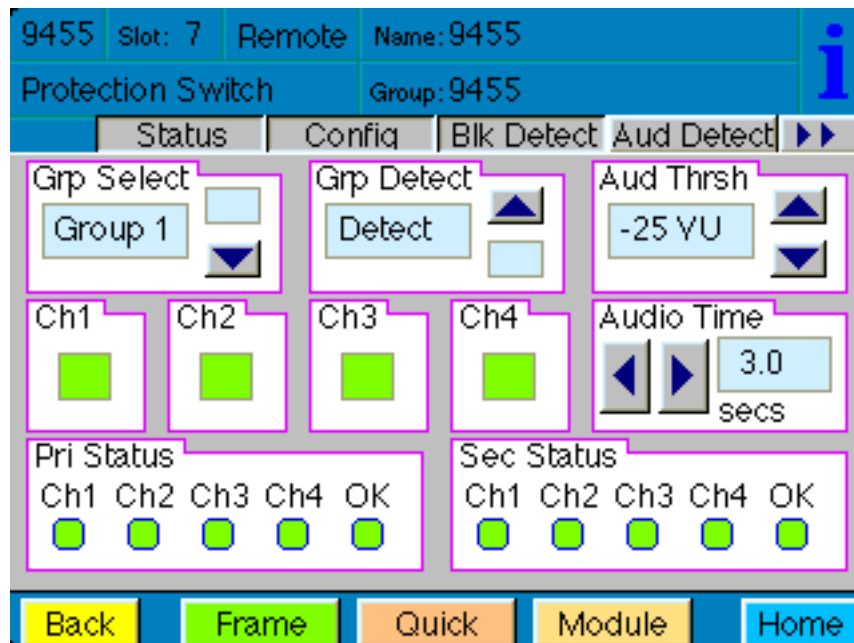

Aud Detect Touch Screen Menu

Freeze Menu

The **Freeze** menu shown on the following page allows you to configure the following parameters for a video freeze condition:

- **Freeze Time** – set the amount of time (0.1 to 300 seconds) for the clean switch to switch to the Secondary input after a video freeze condition is detected.

Default setting is 3 seconds.

The following status indicators can be monitored by Avenue PC alarm functions.

- **Pri Frz Status** – indicates the freeze status of the Primary as **Frozen** or **Unfrozen**.
- **Sec Frz Status** – indicates the freeze status of the Secondary as **Frozen** or **Unfrozen**.

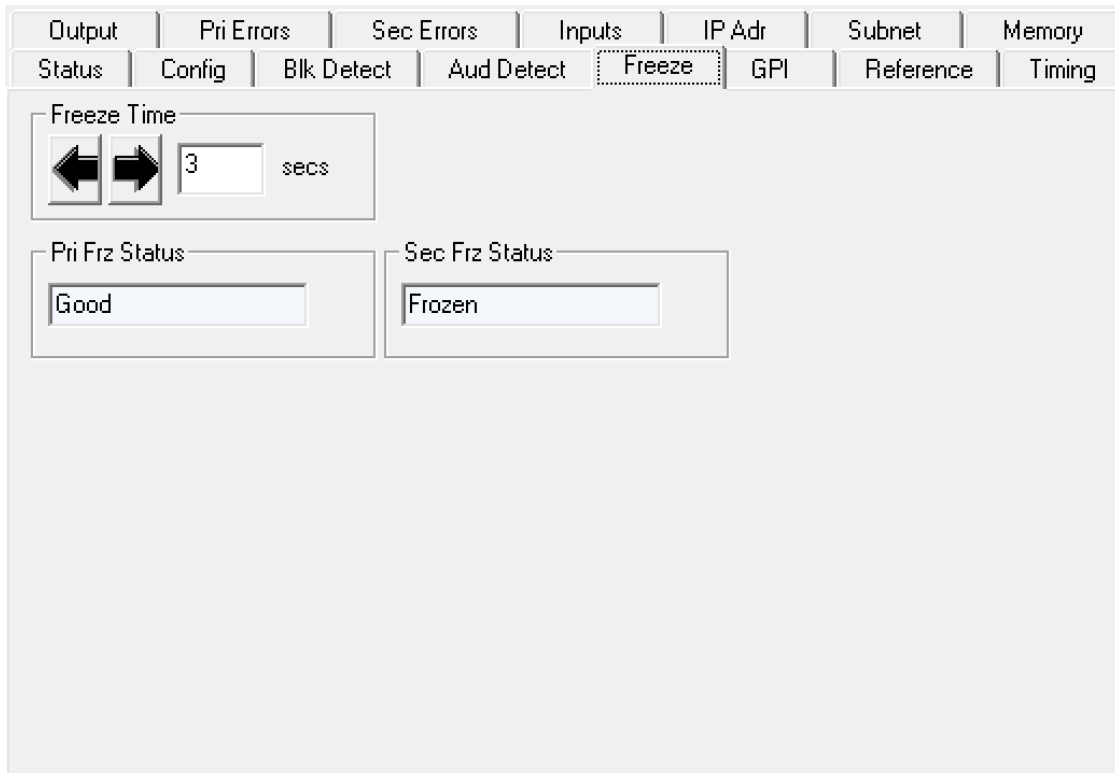

Freeze Avenue PC Menu

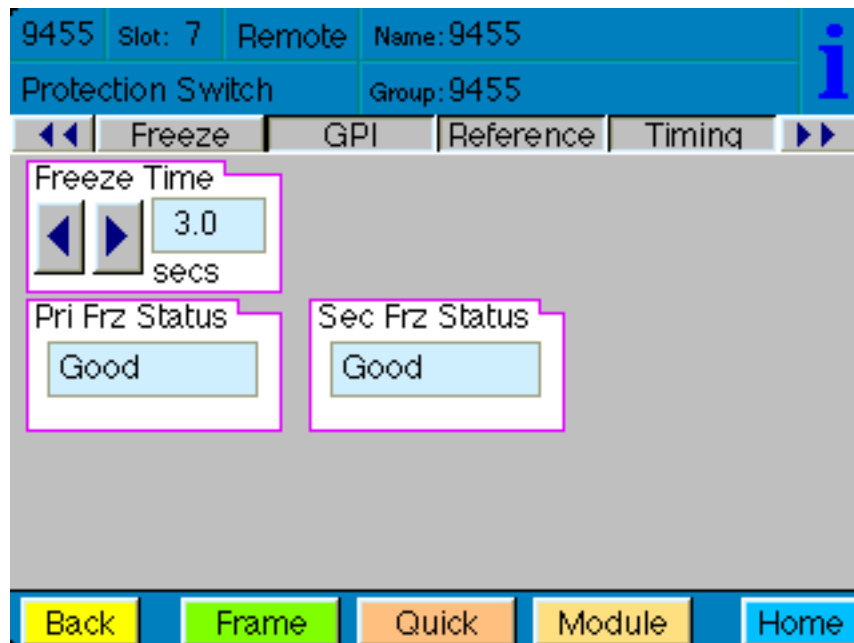

Freeze Touch Screen Menu

General Purpose Interface: GPI/GPO

In addition to full monitoring and access through the control system, 9455 and 7435 modules provide contact closure status indications. The 9455/7435 can be configured to work with external devices through the GPI interface via the 23700048 Interface Adapter Cable. The 9455/7435 module's GPI output connections can drive an alarm system or other external devices, including LEDs. The module's two override GPI inputs are accessed through the 9 pin D connector and are enabled through Avenue PC software. When the module's GPI inputs are closed to ground, these overrides will force the switch to either Primary or Secondary. The GPI inputs are edge-triggered on a negative pulse, or simply a falling edge. These inputs may also be used to switch back to the Primary after a fault has cleared.

The 23700048 Interface Adapter Cable connects to the 15 pin D connector on the back of the Avenue frame that is associated with the clean switch module. This cable comes with each clean switch module and provides a 9 pin D connector for GPI/GPO control, and an Ethernet port for software upgrades. Please see the photo below as well as the illustrations on the following page for detailed cable and pinout information.

Ensemble Designs p/n 23700048 Interface Adapter Cable, pictured below, is included with each 9455 and 7435 Clean Protection Switch module. This "Y" adaptor cable provides a 9-pin D connector for GPI control, and an Ethernet connection for software upgrades.



Connect the male 15 pin D connector to the female 15 pin D connector on the rear of the Avenue frame that corresponds to the 9455/7435 clean switch module.

Ethernet port for software upgrades.

9 pin female D connector for control. Pinouts and details are on the following pages.

23700048 Interface Adapter Cable Drawing and Pinouts

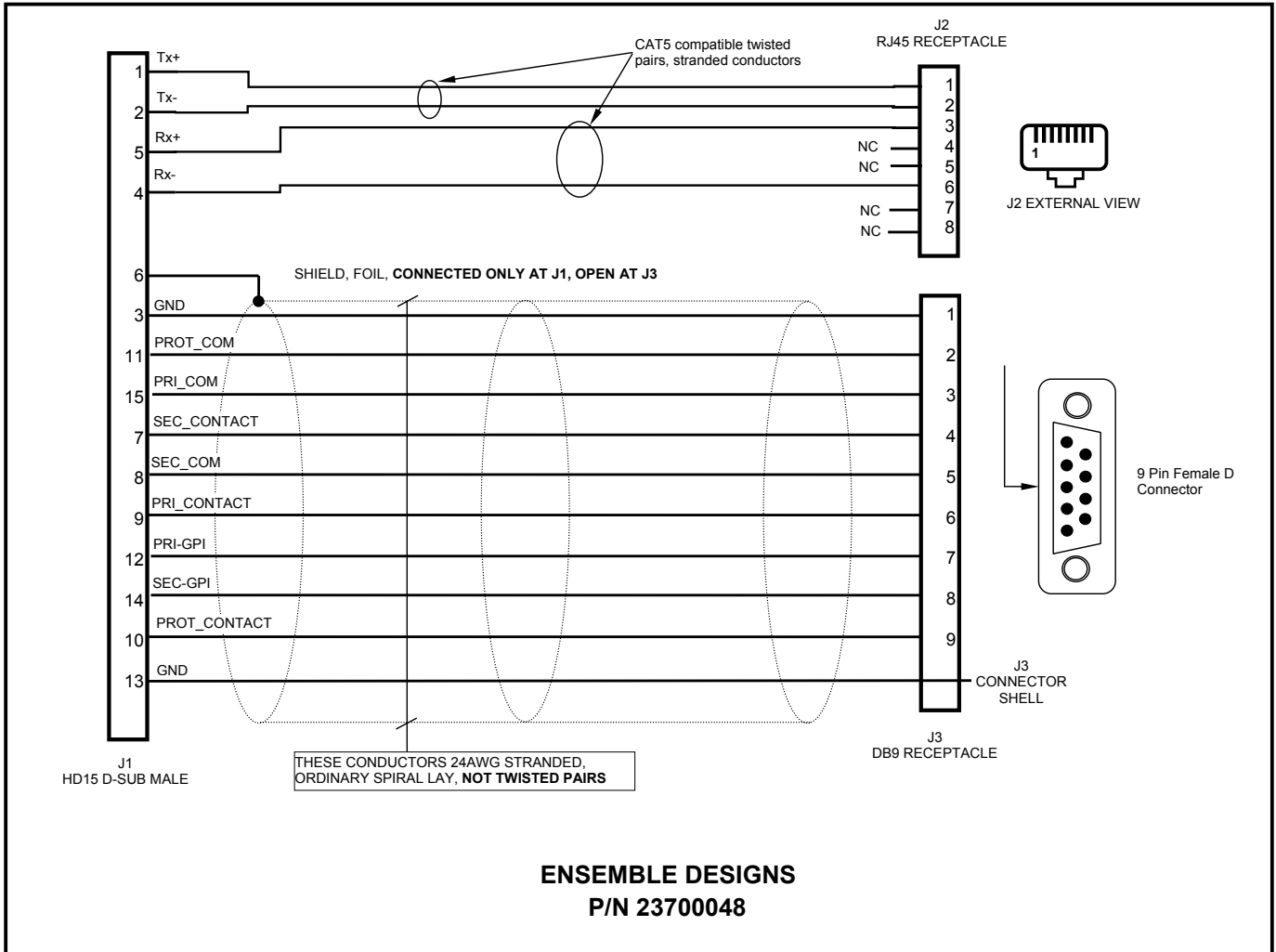

9 pin female D connector

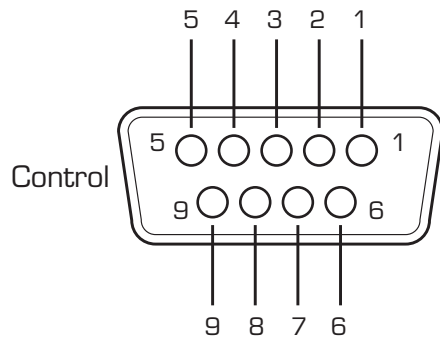

PIN	FUNCTION
1	Gnd
2	Prot Com
3	Pri Com
4	Sec Contact
5	Sec Com
6	Pri Contact
7	Pri GPI
8	Sec GPI
9	Prot Contact

GPI Menu

The **GPI** menu screen shown on the following page allows configuration of the two external GPI inputs. The two Override GPI inputs will force the switch to either Primary or Secondary when closed to ground. The GPI inputs are edge-triggered on a negative pulse, or simply a falling edge. These inputs may also be used to switch back to the Primary after a fault has cleared.

The **Primary GPI Mode** can be set to one of the following:

- **Off** – disables the Primary GPI input, located on pin 7 of the 9 pin female D connector.
- **Neg Edge Switch** – tells the processor to force to the Primary if ground is input into pin 7 of the 9 pin female D connector (switches on a low-going transition to the GPI input).
- **Neg Edge Reg 1** – tells the processor to switch to the Memory Register 1 presets if ground is input into pin 7 of the 9 pin female D connector (switches on a low-going transition to the GPI input).

The **Secondary GPI Mode** can be set to one of the following:

- **Off** – disables the Secondary GPI input, located on pin 8 of the 9 pin female D connector.
- **Neg Edge Switch** – tells the processor to force to the Secondary if ground is input into pin 8 of the 9 pin female D connector (switches on a low-going transition to the GPI input).
- **Neg Edge Reg 1** – tells the processor to switch to the Memory Register 1 presets if ground is input into pin 8 of the 9 pin female D connector (switches on a low-going transition to the GPI input).

The **Pri GPI Status** report window indicates the GPI status as either:

- **GPI is Low**
- **GPI is High**

The **Sec GPI Status** report window indicates the GPI status as either:

- **GPI is Low**
- **GPI is High**

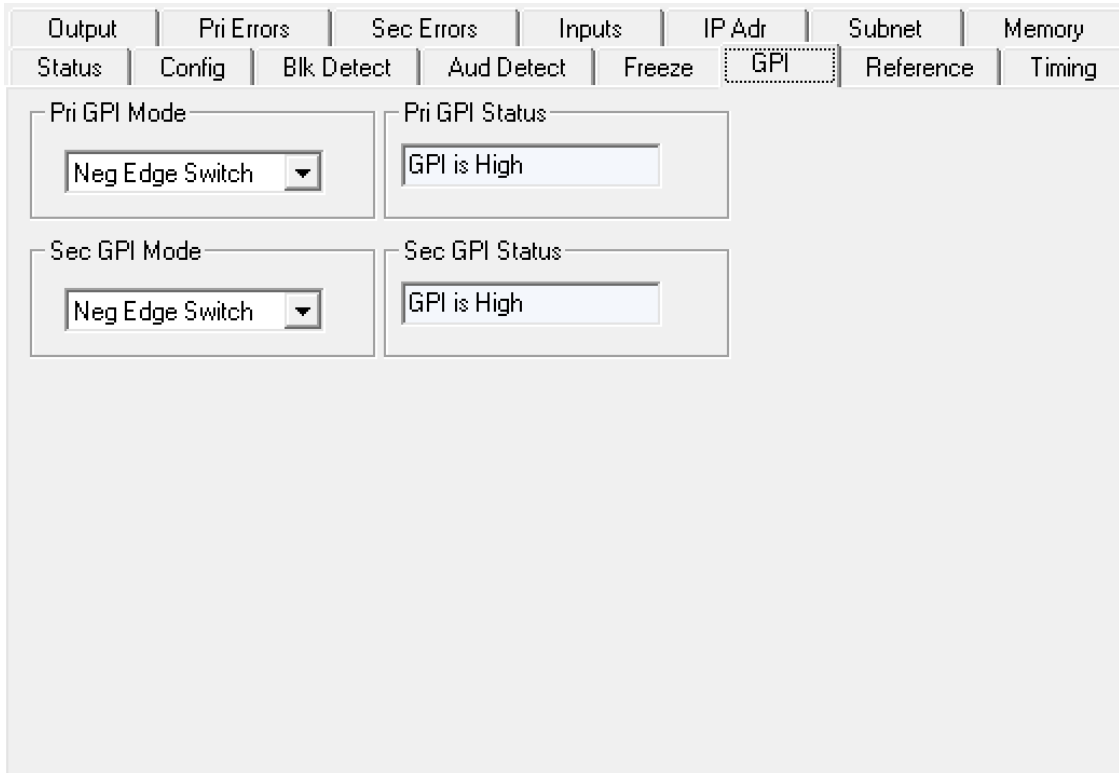

GPI Avenue PC Menu

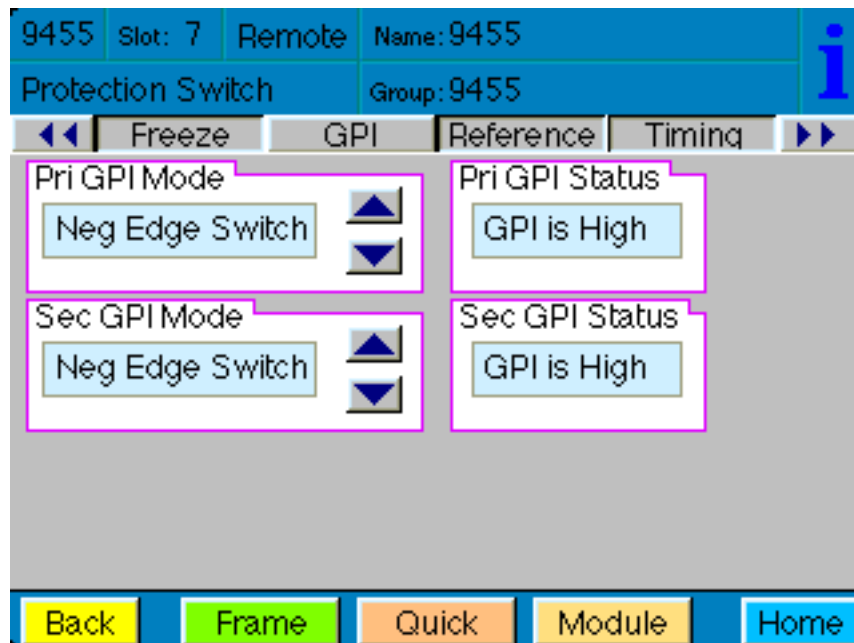

GPI Touch Screen Menu

GPI Output Jumpers

The GPI outputs for the Primary, Secondary and Switch Position are controlled by a series of relays and jumpers on the module.

The relay contacts provide both NO (Normally Open) and NC (Normally Closed) switching to indicate fault status of the Primary and Secondary inputs, and the Protection Switch output. Normally Closed indicates that the signal is good. Select Normally Open (NO) or Normally Closed (NC) via the 2 position headers; H5, H6 and H7 (see illustration below, and details on the following page).

An individual common is provided to each of the relays. For each of the three status relays there is a 3 position header which configures the common signal that will be used by that relay. Each GPI output is independently strappable to provide Ground, current limited +3.3V (1k resistor), or a Common. Select Ground, +3.3 volts or Common via the 3 position headers; H1, H2 and H3 (see illustration below, and details on the following page).

As an example, with jumpers for the Primary set to **NC** and **+3.3V**, the Primary Contact output (pin 6 of the 9 pin D connector) will source +3.3 volts when the relay is in the normal position, closed (Signal Good). If the signal fails, the output will be open.

Additionally, in the case of selecting **+3.3V** as the common, the 1k resistor on the module will act as a current limiter, allowing the direct connection of ordinary LEDs to each of the output pins. A green LED could be connected to the Primary Contact output and a red LED to the Protection Contact output. This would provide complete and explicit indication to the operator as to the signal status and switch position.

Close up of relay section and associated jumpers on the 9455 module

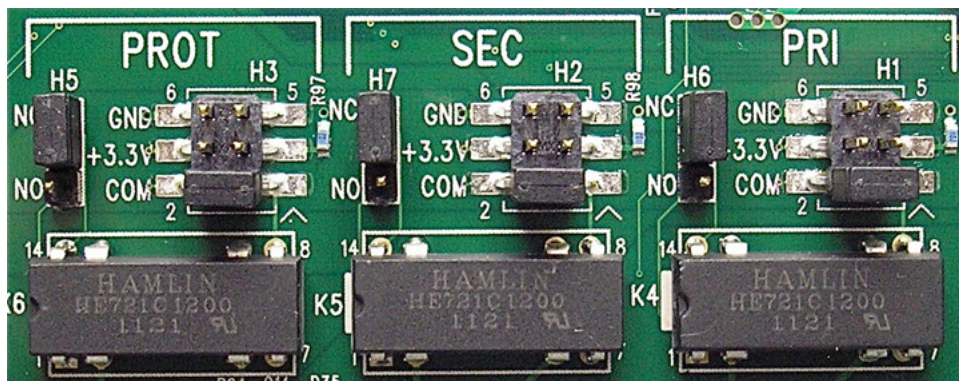

The **Primary Jumpers** can be set as follows:

- **NC or NO** – set the jumper on H6 to **NC** (Normally Closed) or **NO** (Normally Open). **Normally Closed** indicates that the signal is **good**.
- **GND** – uses ground as the relay common. Set the jumper on H1 to the **GND** (ground) position to output ground on the **Pri Contact** pin of the 9 pin female D connector (pin 6).
- **+3.3V** – provides a +3.3 volt signal through a 1k resistor to the relay common. Set the jumper on H1 to the **+3.3V** position to output +3.3 volts on the **Pri Contact** pin of the 9 pin female D connector (pin 6).
- **COM** – uses the user-provided common signal from the Control connector. Use this when something other than ground or 3.3 volts is needed. Set the jumper on H1 to the **COM** (common) position and feed the desired signal into the **Pri Com** pin (pin 3) of the 9 pin female D connector. This signal will loop through and be output on the **Pri Contact** pin (pin 6).

The **Secondary Jumpers** can be set as follows:

- **NC or NO** – set the jumper on H7 to **NC** (Normally Closed) or **NO** (Normally Open). **Normally Closed** indicates that the signal is **good**.
- **GND** – uses ground as the relay common. Set the jumper on H2 to the **GND** (ground) position to output ground on the **Sec Contact** pin of the 9 pin female D connector (pin 4).
- **+3.3V** – provides a +3.3 volt signal through a 1k resistor to the relay common. Set the jumper on H2 to the **+3.3V** position to output +3.3 volts on the **Sec Contact** pin of the 9 pin female D connector (pin 4).
- **COM** – uses the user-provided common signal from the Control connector. Use this when something other than ground or 3.3 volts is needed. Set the jumper on H2 to the **COM** (common) position and feed the desired signal into the **Sec Com** pin (pin 5) of the 9 pin female D connector. This signal will loop through and be output on the **Sec Contact** pin (pin 4).

The **Prot Jumpers** can be set as follows:

- **NC or NO** – set the jumper on H5 to **NC** (Normally Closed) or **NO** (Normally Open). **Normally Closed** indicates that the switch is in the **Primary** position.
- **GND** – uses ground as the relay common. Set the jumper on H3 to the **GND** (ground) position to output ground on the **Prot Contact** pin of the 9 pin female D connector (pin 9).
- **+3.3V** – provides a +3.3 volt signal through a 1k resistor to the relay common. Set the jumper on H3 to the **+3.3V** position to output +3.3 volts on the **Prot Contact** pin of the 9 pin female D connector (pin 9).
- **COM** – uses the user-provided common signal from the Control connector. Use this when something other than ground or 3.3 volts is needed. Set the jumper on H3 to the **COM** (common) position and feed the desired signal into the **Prot Com** pin (pin 2) of the 9 pin female D connector. This signal will loop through and be output on the **Prot Contact** pin (pin 9).

Reference Menu

The module genlocks to either composite video (PAL or NTSC) or to Tri-Level Sync. The module can lock to the frame's master reference or reference can be connected directly to the module's external Ref In BNC. The **Reference** menu shown below allows you to select your reference source, and provides reporting information for the reference status and sync lock.

- **Ref Source** – select the reference source from **Master Ref** or **External Ref**.
If no reference is connected, or the reference fails, the module will switch to it's own internal precision reference.

- **Ref Status** – reports the reference input and status as one of the following:

No Reference
Ref 525
Ref 525 w/VITC
Ref 625
Ref 625 w/VITC
Ref 720p/5994 TLS (note this will be the report for both 720p/59.94 TLS and 720p/60 TLS
Ref 720p/50 TLS
Ref 1080i/5994 TLS (note this will be the report for both 1080i/59.94 TLS and 720p/60 TLS
Ref 1080i/50 TLS
Ref 1080sF/24
Ref 1080p/24
Ref 1080p/25
Ref 10 Mhz

- **Sync lock** – indicates the sync lock status as one of the following:

Unlocked
Lock 525
Lock 625
Lock TLS
Lock 10M
Lock Internal
*** No Ref ***

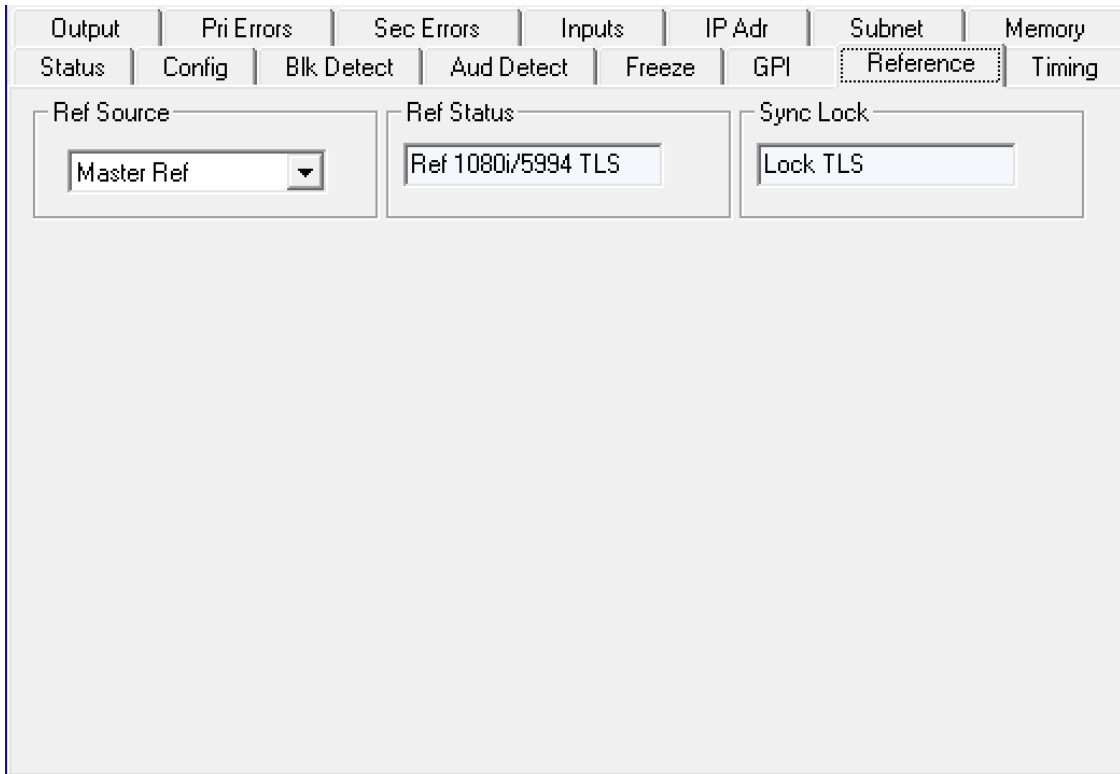

Reference Avenue PC Menu

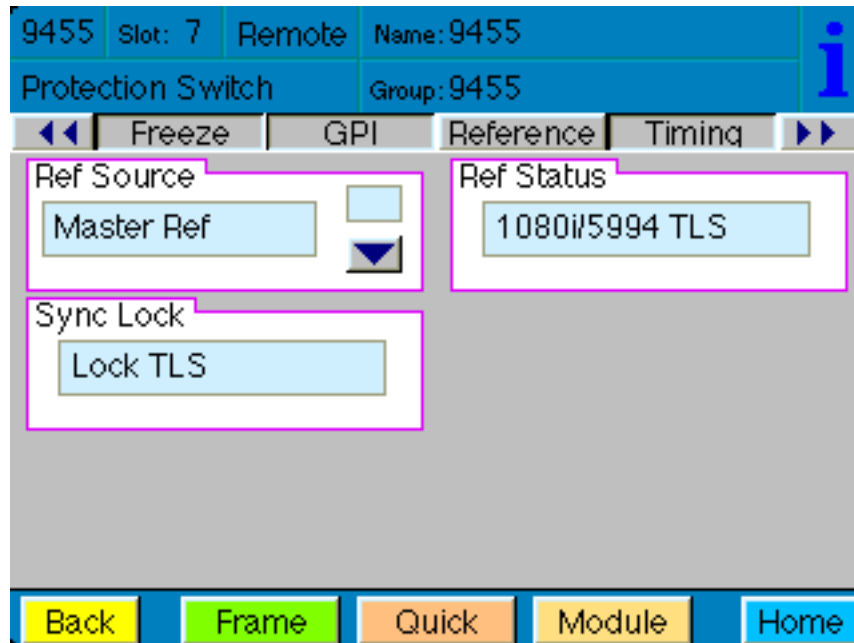

Reference Touch Screen Menu

Timing Menu

The **Timing** menu screen shown on the following page allows you to set the amount of additional delay you would like to add to the Primary and the Secondary, and to adjust the vertical and horizontal timing.

The delay through the 9455 or 7435 can be adjusted up to six frames, with independent control for the primary and secondary input paths. By operating with several frames of delay, the fault detection algorithms are given enough time to detect a failure in an input signal and switch to the backup before the fault has actually appeared on-air.

- **Frame Delay 1** – adjust the amount of delay for the Primary up to 6 frames.
- **Frame Delay 2** – adjust the amount of delay for the Secondary up to 6 frames.

The Vertical and Horizontal Timing controls adjust the timing of the video signal relative to the timing reference. Setting the Vertical and Horizontal parameters to 0 (the default setting) will “zero” time the video signal to the reference. Negative values will cause the video signal to be early with respect to the reference. Positive values will make the video signal later in time with respect to the reference.

- **Vertical Timing** – When the Frame Sync is on, adjust the vertical timing of the output signal to place the leading edge of sync to coincide with other sources.
- **Horizontal Timing** – When the Frame Sync is on, adjust the horizontal timing of the output signal to place the leading edge of sync to coincide with other sources.

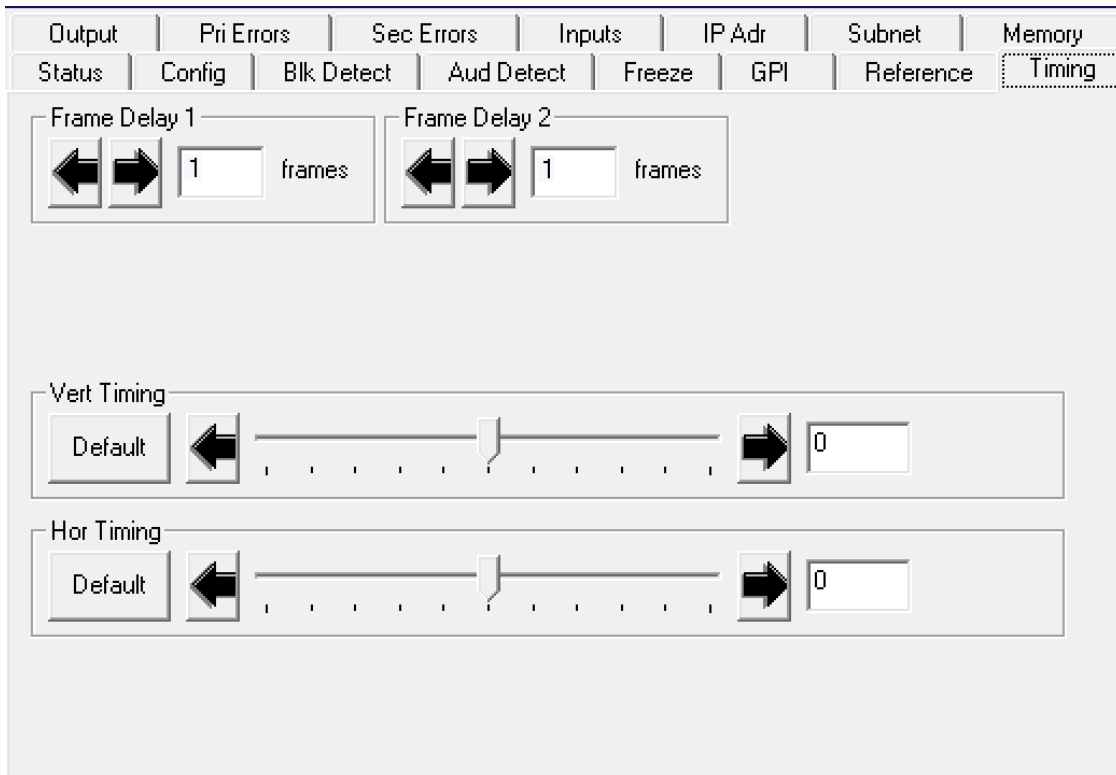

Timing Avenue PC Menu

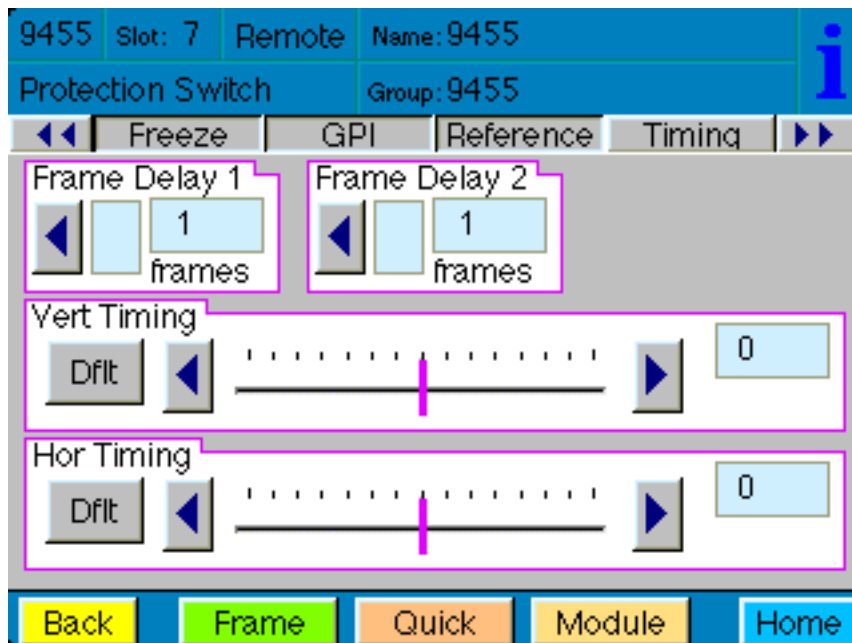

Timing Touch Screen Menu

Pri Errors Menu

The **Pri Errors** menu shown below displays the amount of time in seconds that each of the error conditions have been present after detection on the Primary as well as the number of times the Primary feed has switched to the Secondary feed (**Sec Sw Cnt**).

The error counters display the number of *cumulative* errors that have occurred since a counter was last reset. Errors may occur as a single event, or as multiple events over a period of time. Refer to the Avenue PC manual to learn how to use the alarms and logging capabilities of Avenue PC to obtain more detailed information on errors.

The upper limit for cumulative errors is 10,000. If an error counter reaches this upper limit, it will repeatedly cycle between 10,000 and 9,999. To reset the error counter, double-click it.

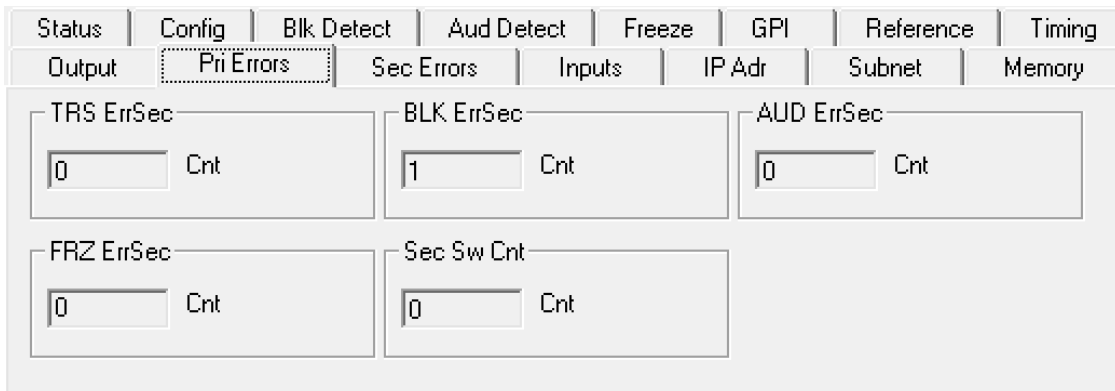

Pri Errors Avenue PC Menu

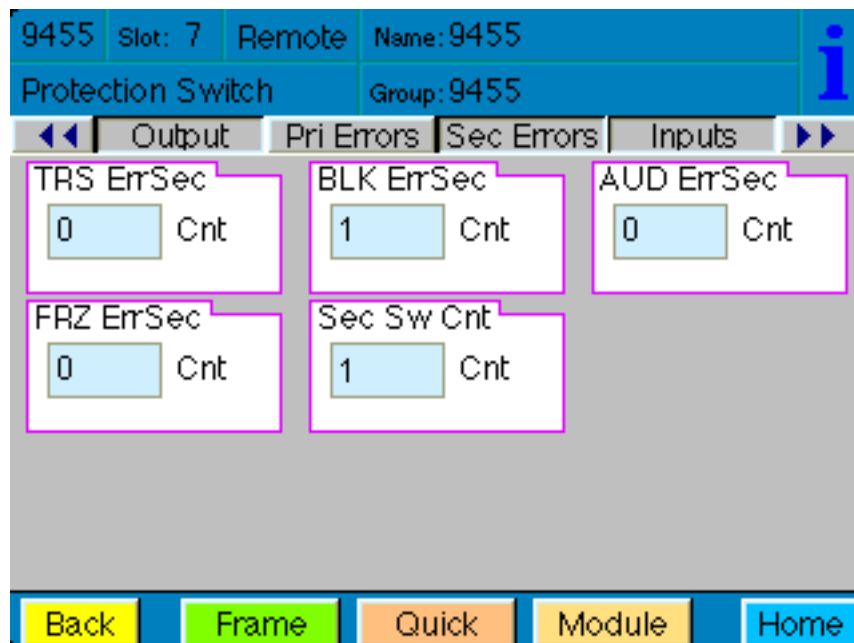

Pri Errors Touch Screen Menu

Sec Errors Menu

The **Sec Errors** menu shown below displays the amount of time in seconds that each of the error conditions have been present after detection on the Primary as well as the number of times the Primary feed has switched to the Secondary feed (**Sec Sw Cnt**).

The error counters display the number of *cumulative* errors that have occurred since a counter was last reset. Errors may occur as a single event, or as multiple events over a period of time. Refer to the Avenue PC manual to learn how to use the alarms and logging capabilities of Avenue PC to obtain more detailed information on errors.

The upper limit for cumulative errors is 10,000. If an error counter reaches this upper limit, it will repeatedly cycle between 10,000 and 9,999. To reset the error counter, double-click it.

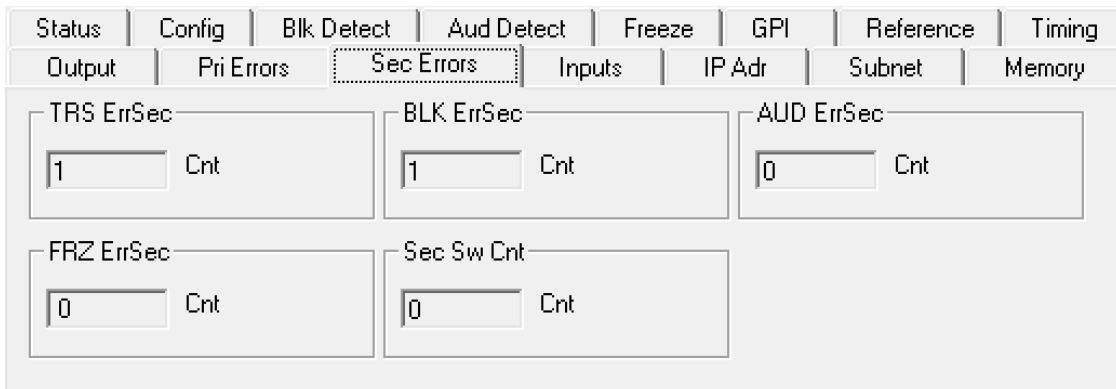

Sec Errors Avenue PC Menu

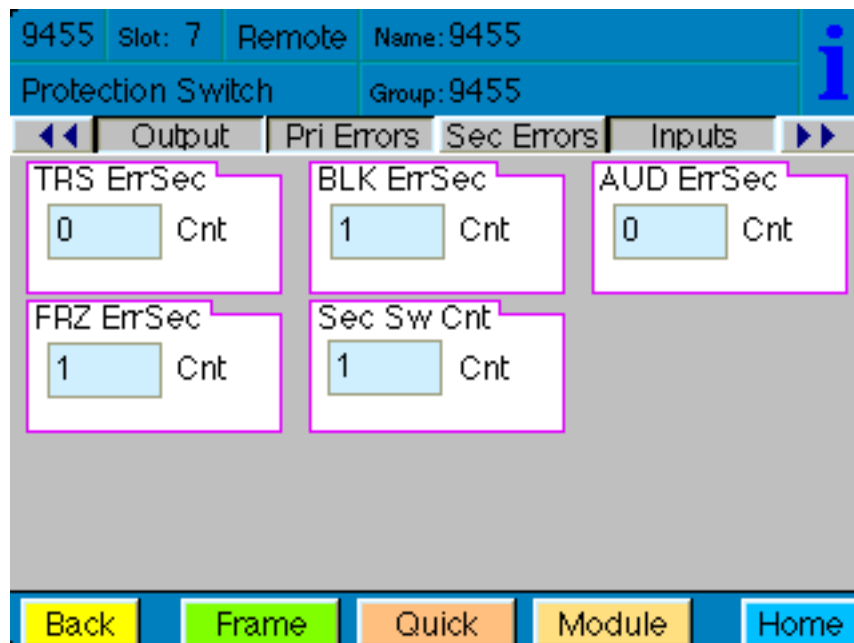

Sec Errors Touch Screen Menu

Inputs Menu

The **Inputs** menu shown on the following page displays the type of signal detected on the Primary and Secondary inputs.

- **Primary Input** displays the HD SDI signal type detected on the Primary Input connector.
- **Secondary Input** displays the HD SDI signal type detected on the Secondary Input connector.

9455 and 7435 input choices are:

720p/50
720p/59.94
720p/60
1080i/50
1080i/59.94
1080i/60
1080p/25
1080p/23.98
1080p/24
3G 1080p/50
3G 1080p/59.94
3G 1080p/60
1080sF/25
1080sF/23.98
1080sF/24
SD525
SD625

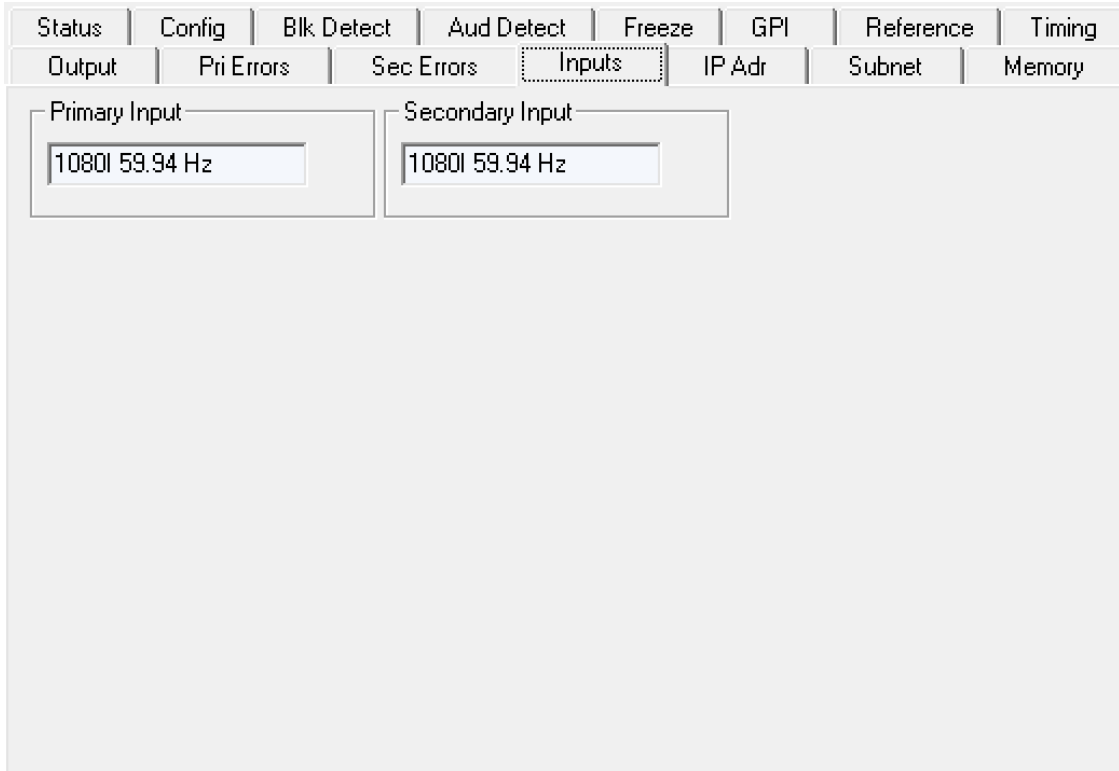

Inputs Avenue PC Menu

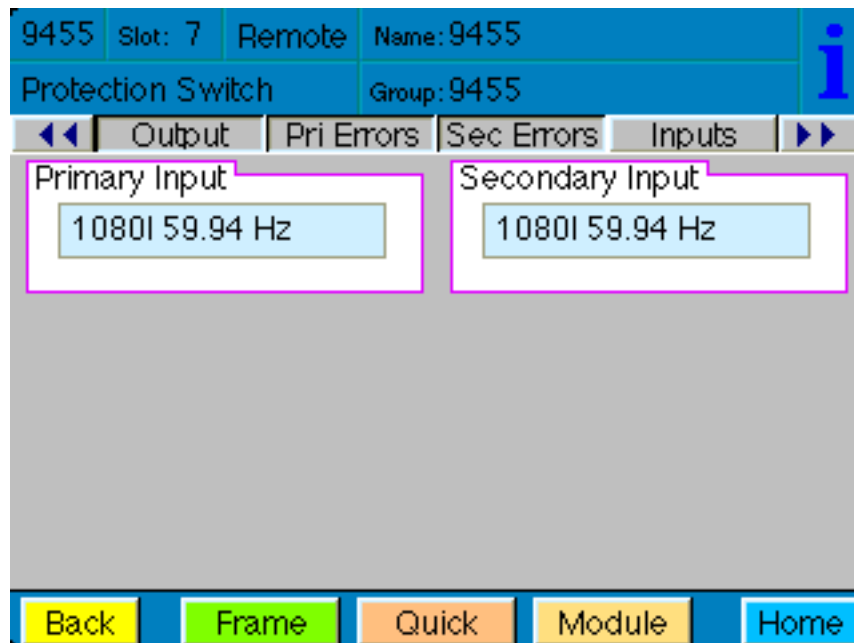

Inputs Touch Screen Menu

Memory Menu

The **Memory** menu allows you to save and recall up to 5 different setups for the 9455/7435 module as follows:

- Click **Save**, then one of the five memory registers **Reg 1 – 5**. The box will turn green. The entire module setup is now saved in the selected register.
- To recall a setup, click the register box. If there is information saved, the box will turn green. The saved setup will load into the module.

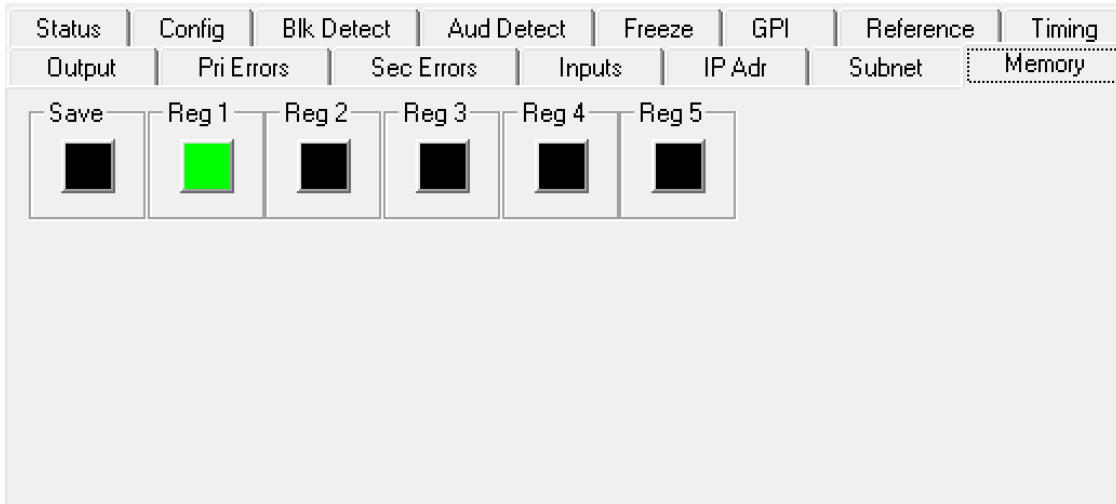

Memory Avenue PC Menu

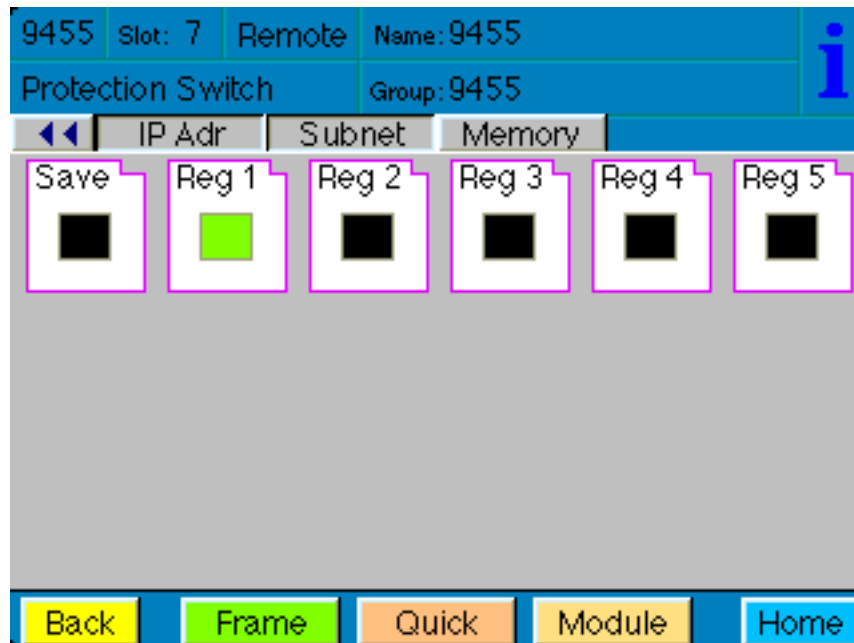

Memory Touch Screen Menu

Software Updates

Software updates for the 9455 and 7435 modules are done via Ethernet. Software updates are free for life and can be downloaded onto your PC or Mac from the following website:

<http://www.ensembledesigns.com/support/avenue-support/avenue-software>

Each 9455 and 7435 comes with a “Y” adaptor cable that provides Ethernet and GPI/GPO control. The 23700048 Interface Adapter Cable cable, shown below, connects to the 15 pin D connector associated with the clean switch module on the back of the Avenue frame. The Ethernet is used for software upgrades and the 9 pin D connector is used for GPI control.

Software updates are done with a web browser through the Ethernet connection, not thorough Avenue PC. A synopsis of the steps for updating software is on the following page. Detailed instruction instructions for updating software in your 9455 or 7435 module follow, including setting the IP address and subnet mask of the 9455/7435 are on the subsequent pages.

The “Y” adaptor cable pictured below is the Ensemble Designs p/n 23700048 Interface Adapter Cable. It provides an Ethernet connection for software upgrades and a 9-pin GPI connector for control.



Connect the male 15 pin D connector to the female 15 pin D connector on the back of the frame that corresponds to the clean switch module

Ethernet port for software upgrades

9 pin female D connector for control.

Step by Step Overview for Updating Software in your 9455 or 7435:

Step 1. Connecting the Cable

Attach the 23700048 Interface Adapter Cable to the 15 pin D connector associated with the clean switch module on the back of the Avenue frame. Connect an Ethernet cable from the Ethernet port end of the "Y" cable to your network. The Ethernet port will auto-sense cable direction, so a cross-over cable is not needed.

Step 2. Setting the IP Address

Use the IP Address menu in Avenue PC or on your Touch Screen to assign a unique IP address to the 9455/7435 module.

Step 3. Setting the Subnet Mask

Use the Subnet menu in Avenue PC or on your Touch Screen to set the subnet mask for the 9455/7435 module.

Step 4. Download Current Software

Download the current software for 9455 or 7435 to your PC or Mac from the following website:

<http://www.ensembledesigns.com/support/avenue-support/avenue-software>

Step 5. Navigate to your 9455/7435 Module through a Web Browser

On a computer that is networked to the Avenue frame, type the IP address of the 9455/7435 into the address bar of your web browser. The Setting: General Information window will come up.

Step 6. Update the Module Software

In the Setting: General Information window, click the Choose File button. Navigate to the software that you downloaded to your computer in Step 4. Click the Start Update button. The Updating Firmware window will come up. The updating process can take several minutes.

Detailed Instructions for Updating Software in your 9455 or 7435:

Updating Software: Step 1. Connecting the Cable

Attach the 23700048 Interface Adapter Cable to the 15 pin D connector associated with the clean switch module on the back of the Avenue frame. Connect an Ethernet cable from the Ethernet port end of the "Y" cable to your network. The Ethernet port will auto-sense cable direction, so a cross-over cable is not needed.

Updating Software: Step 2. Setting the IP Address

Assign a unique IP address to the 9455/7435 module. Use the IP Address menu in Avenue PC or on your Touch Screen. The IP Address menu is detailed below and illustrated on the following page.

IP Adr Menu

The **IP Adr** menu shown on the following page allows you to change the IP address of your 9455/7435 module. When you initially power up the 9455 or 7435 as received from the factory, it will take the self-assigned static IP address of 192.168.1.100. In order to use the Ethernet port to update module software, you will need to assign a new IP address.

These are general instructions. We recommend that you consult your IT staff if you are uncertain about any of these network configuration settings.

To Set the IP Address

1. From the **IP Adr** menu, enter the IP address you want to use that is compatible with your own network. The simplest method is to touch each number field, using the keypad to enter the new numbers. For example, you may want to change the IP address to something like the following: 10.123.222.100. These are general instructions. We recommend that you consult your IT staff if you are uncertain about any of the network configuration settings.
2. Press **Save**. Both the **Cancel** and **Save** buttons turn black to indicate that your new settings have been saved.

Note that when using Avenue PC instead of the Touch Screen interface, after entering numbers into the number fields, you will need to hit the "enter" or "return" key for the change to register.

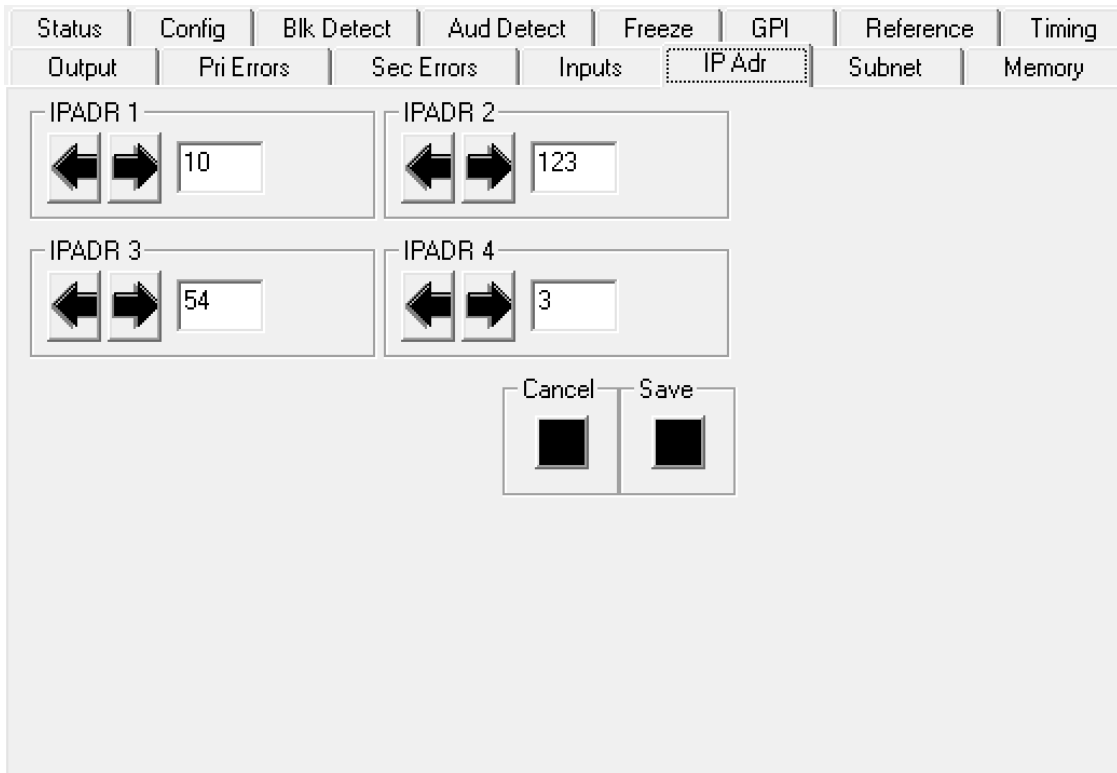

IP Adr Avenue PC Menu

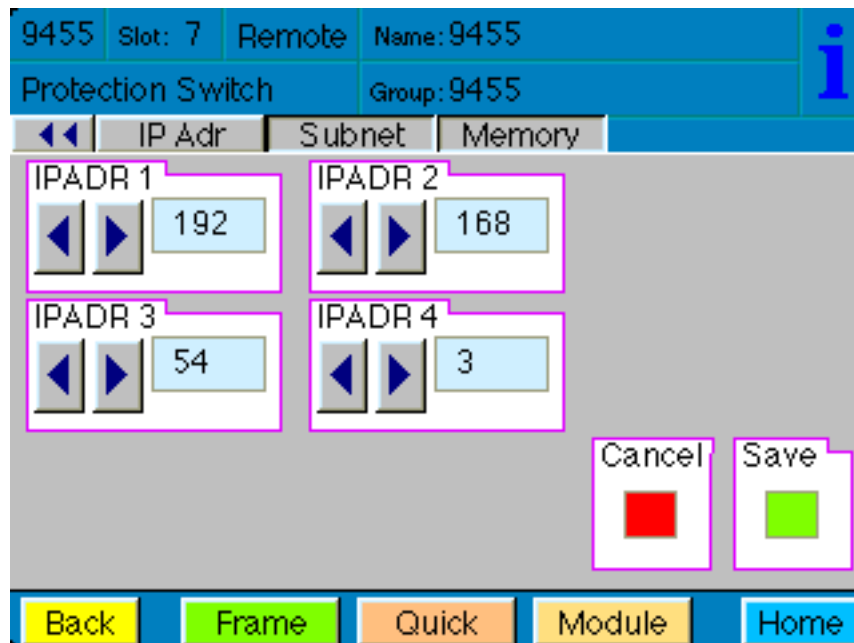

IP Adr Touch Screen Menu

Updating Software: Step 3

Set the subnet mask for the 9455/7435 module. Use the Subnet menu in Avenue PC or on your Touch Screen. The Subnet menu is detailed below and illustrated on the following page.

Subnet Menu

The **Subnet** menu shown on the following page allows you to change the subnet mask of your 9455/7435 module. In order to use the Ethernet port to update module software, the subnet mask must be set in accordance with the size and topology of your network. The default setting as received from the factory is for a smaller network: 255.255.255.0. For a larger network, a typical setting is 255.255.0.0. If in doubt, use the setting for a larger network.

These are general instructions. We recommend that you consult your IT staff if you are uncertain about any of these network configuration settings.

To Set the Subnet Mask

1. From the **Subnet** menu, modify the settings as needed. Use the arrow buttons to change the settings, or touch each number field to use the keypad.
2. When finished, press **Save**. Both the **Cancel** and **Save** buttons turn black to indicate that your new settings have been saved.

Note that when using Avenue PC instead of the Touch Screen interface, after entering numbers into the number fields, you will need to hit the "enter" or "return" key for the change to register.

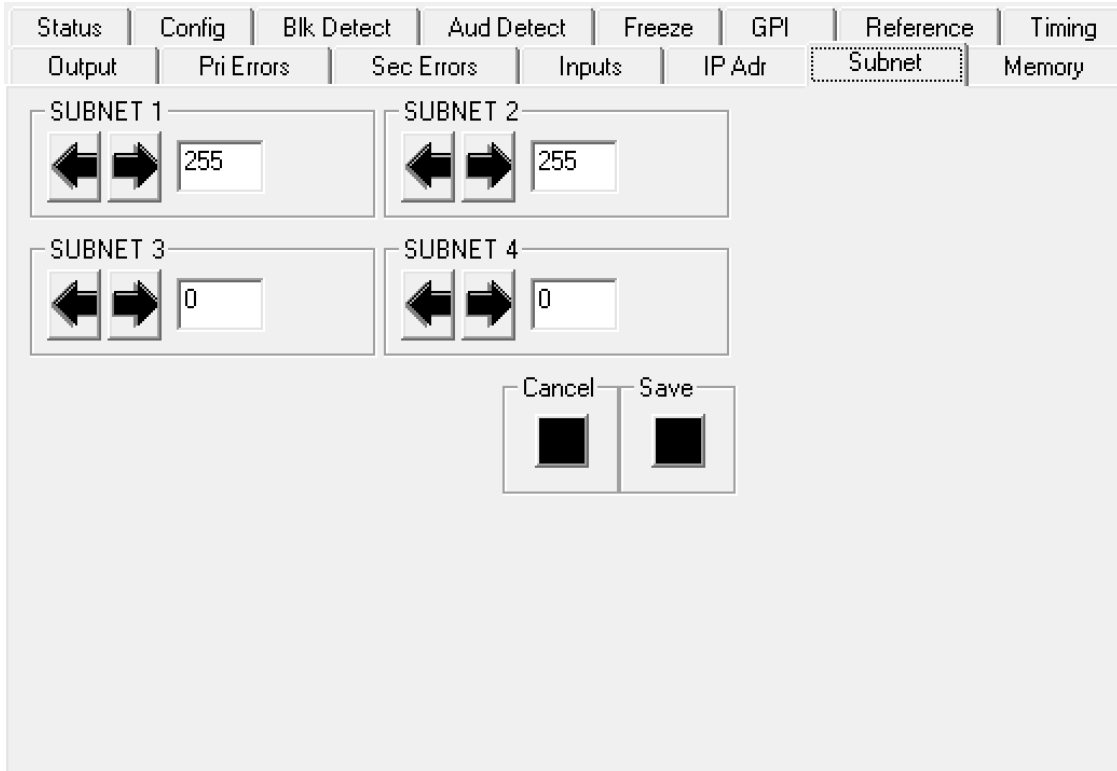

Subnet Avenue PC Menu

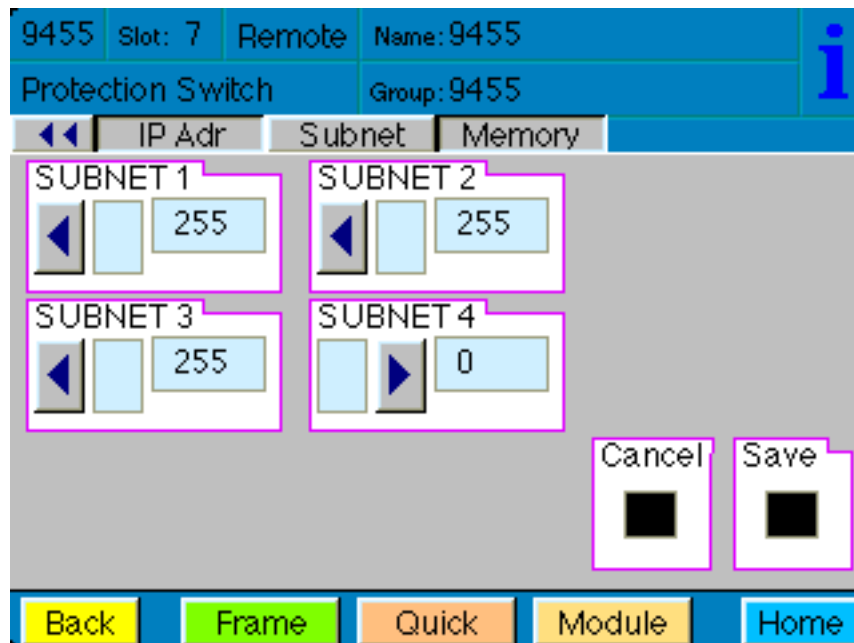

Subnet Touch Screen Menu

Updating Software: Step 4. Download Current Software

Download the current software for 9455 or 7435 to your PC or Mac from the following website:

<http://www.ensembledesigns.com/support/avenue-support/avenue-software>

Updating Software: Step 5. Navigate to your 9455/7435 Module through a Web Browser

On a computer that is networked to the Avenue frame, type the IP address of the 9455/7435 into the address bar of your web browser. The Setting: General Information window will come up, shown below.

The screenshot shows a web browser interface for the 'Settings' page of a Protection Switch. The page is titled 'Settings' and has a sidebar with 'General' and 'Network' options. The main content area is divided into three sections: 'General Information', 'Security', and 'Update'.

General Information

Router Name: 7435

Router Information

Model	Module Hardware	Module Software	CGI	WebUI
7435 - Protection Switch	7435 45009455 A	1.0.0	1.0.0d2_j1	1.0.0d3

Serial Number: DYBM1026

Bootloader: 1.0.3-0019

Kernel: 1.0.3-0019

Security

Admin Password

Required

Update

Load Software

no file selected

Upload an ".esu" software update package to begin the software update process. The update process may take several minutes. Make sure that you don't remove power during the update process.

Updating Software: Step 6. Update the Module Software

In the Setting: General Information window, click the Choose File button and navigate to the software that you downloaded to your computer in Step 4. Click the Start Update button. The Updating Firmware window, shown below, will come up. The updating process can take several minutes.

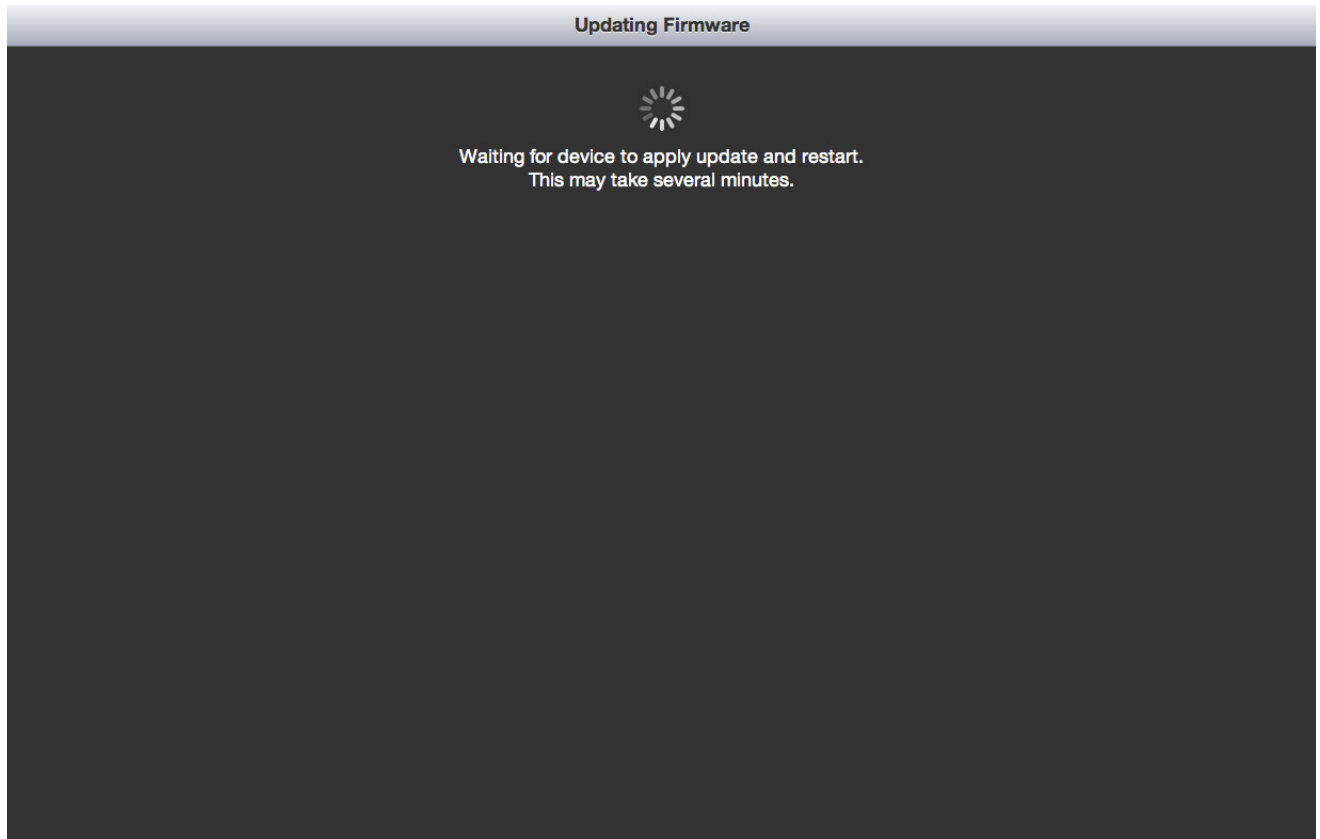

Troubleshooting

As a troubleshooting aid, reference signal status and presence, as well as power and CPU status can be easily monitored from the front panel of the 9455/7435 module using the front panel indicators.

Refer to the troubleshooting tips below:

Module is outputting black

- Check the Output setting in the Output menu. If the module cannot find a good signal on the Primary or the Secondary, it will output consistently timed black. In this situation, both the Primary and Secondary buttons will be grey and the **Switch Position** window will report **Int Blk**. The most likely cause of this is an incorrectly set Output Format. The Output Format is set in the **Output Menu** and must match the format of the Primary and Secondary inputs. The Input Formats are auto detected and show in the Primary and Secondary Input report windows in the **Input Menu**.

Can't control module

- Check status of CPU Run green LED. Should be blinking slowly and in unison with other modules if 5030 System Control module is present. If not, try removing the 9455/7435 and plugging it in again to be sure it is seated properly.
- 5030 System Control module may not be working properly if installed.

Module remote controls are grayed out

- Module is locked or access to module controls is restricted by User Level.

No signal out of module

- Check status of Active LEDs. Primary or Secondary should be lit. If not, check the inputs for signal presence and quality.
- Check cabling to input of the module.

Please also refer to the technical support section of the Ensemble Designs web site for the latest information on your equipment at the URL below:

<http://www.ensembledesigns.com/support>

Warranty and Factory Service

Warranty

This module is covered by a five-year limited warranty, as stated in the main Preface of this manual. If you require service (under warranty or not), please contact Ensemble Designs and ask for customer service before you return the unit. This will allow the service technician an opportunity to provide any other suggestions for identifying the problem and to recommend possible solutions.

Factory Service

If you return equipment for repair, please get a Return Material Authorization Number (RMA) from the factory first.

Ship the product and a written description of the problem to:

Ensemble Designs, Inc.
Attention: Customer Service RMA #####
870 Gold Flat Rd.
Nevada City, CA 95959 USA

tel +1 530.478.1830
fax +1 530.478.1832

service@ensembledesigns.com

www.ensembledesigns.com

Be sure to put your RMA number on the outside of the box.

Specifications

Input

Number	Two
Signal Type	HD Serial Digital 1.485 Gb/s, SMPTE 274M, 292M or 296M HD Serial Digital 2.97 Gb/s, SMPTE 424M, 425M (9455 Only) SD Serial Digital 270 Mb/s, SMPTE 259M Data, SMPTE 337M
Impedance	75 Ω
Return Loss	>15 dB to 1.5 GHz
Max Cable Length	270 Mb/s 300 meters Belden 1694A 1.485 Gb/s 100 meters Belden 1694A 2.97 Gb/s 70 meters Belden 1694A

Automatic Cable Input Equalization

Standards Supported

1080i 50, 59.94 or 60 Hz, SMPTE 274M -4,5,6
720p 50, 59.94 or 60 Hz, SMPTE 296M -1,2,3
1080p 23.98, 24 or 25 Hz, SMPTE 274M -9,10,11
1080p 50, 59.94 Hz, SMPTE 424M, 425M Level A (9455 Only)
1080sF 23.98, 24 or 25 Hz, RP211 -14,15,16
625i 50, 525i 59.94

Serial Digital Loopback

Number	Two total One primary One secondary
Impedance	75 Ω

Output

Number	Six (includes one fail-safe bypass)
Signal Type	HD or SD Serial Digital, follows input
Delay	Adjustable up to 6 frames
Impedance	75 Ω
Return Loss	>15 dB DC to 1.5 GHz

Reference Input

Number	One external (modules BNC) One internal (frame master ref BNC)
Signal Type	PAL or NTSC composite video or Tri-Level Sync
Return Loss	>40 dB

General Specifications

Power Consumption	10 watts
Temperature Range	0 to 40°C ambient (all specs met)
Relative Humidity	0 to 95%, noncondensing
Altitude	0 to 10,000 ft

9455 and 7435 modules cannot be installed in slot 3 of a 1RU frame when 5035 System Control module is installed

Glossary

AES/EBU

The digital audio standard defined as a joint effort of the Audio Engineering Society and the European Broadcast Union. AES/EBU or AES3 describes a serial bitstream that carries two audio channels, thus an AES stream is a stereo pair. The AES/EBU standard covers a wide range of sample rates and quantizations (bit depths). In television systems, these will generally be 48 KHz and either 20 or 24 bits.

AFD

Active Format Description is a method to carry information regarding the aspect ratio of the video content. The specification of AFD was standardized by SMPTE in 2007 and is now beginning to appear in the marketplace. AFD can be included in both SD and HD SDI transport systems. There is no legacy analog implementation. (See WSS).

ASI

A commonly used transport method for MPEG video streams, ASI or Asynchronous Serial Interface, operates at the same 270 Mb/s data rate as SD SDI. This makes it easy to carry an ASI stream through existing digital television infrastructure. Known more formally as DVB-ASI, this transport mechanism can be used to carry multiple program channels.

Aspect Ratio

The ratio of the vertical and horizontal measurements of an image. 4:3 is the aspect ratio for standard definition video formats and television and 16:9 for high definition. Converting formats of unequal ratios is done by letterboxing (horizontal bars) or pillar boxing (vertical pillars) in order to keep the original format's aspect ratio.

Bandwidth

Strictly speaking, this refers to the range of frequencies (i.e. the width of the band of frequency) used by a signal, or carried by a transmission channel. Generally, wider bandwidth will carry and reproduce a signal with greater fidelity and accuracy.

Beta

Sony Beta SP video tape machines use an analog component format that is similar to SMPTE, but differs in the amplitude of the color difference signals. It may also carry setup on the luminance channel.

Bit

A binary digit, or bit, is the smallest amount of information that can be stored or transmitted digitally by electrical, optical, magnetic, or other means. A single bit can take on one of two states: On/Off, Low/High, Asserted/ Deasserted, etc. It is represented numerically by the numerals 1 (one) and 0 (zero). A byte, containing 8 bits, can represent 256 different states. The binary number 11010111, for example, has the value of 215 in our base 10 numbering system. When a value is carried digitally, each additional bit of resolution will double the number of different states that can be represented.

Systems that operate with a greater number of bits of resolution, or quantization, will be able to capture a signal with more detail or fidelity. Thus, a video digitizer with 12 bits of resolution will capture 4 times as much detail as one with 10 bits.

Blanking

The Horizontal and Vertical blanking intervals of a television signal refer to the time periods between lines and between fields. No picture information is transmitted during these times, which are required in CRT displays to allow the electron beam to be repositioned for the start of the next line or field. They are also used to carry synchronizing pulses which are used in transmission and recovery of the image. Although some of these needs are disappearing, the intervals themselves are retained for compatibility purposes. They have turned out to be very useful for the transmission of additional content, such as teletext and embedded audio.

CAV

Component Analog Video. This is a convenient shorthand form, but it is subject to confusion. It is sometimes used to mean ONLY color difference component formats (SMPTE or Beta), and other times to include RGB format. In any case, a CAV signal will always require 3 connectors – either Y/R-Y/B-Y, or R/G/B.

Checkfield

A Checkfield signal is a special test signal that stresses particular aspects of serial digital transmission. The performance of the Phase Locked-Loops (PLLs) in an SDI receiver must be able to tolerate long runs of 0's and 1's. Under normal conditions, only very short runs of these are produced due to a scrambling algorithm that is used. The Checkfield, also referred to as the Pathological test signal, will "undo" the scrambling and cause extremely long runs to occur. This test signal is very useful for testing transmission paths.

Chroma

The color or chroma content of a signal, consisting of the hue and saturation of the image. See also Color Difference.

Component

In a component video system, the totality of the image is carried by three separate but related components. This method provides the best image fidelity with the fewest artifacts, but it requires three independent transmission paths (cables). The commonly used component formats are Luminance and Color Difference (Y/Pr/Pb), and RGB. It was far too unwieldy in the early days of color television to even consider component transmission.

Composite

Composite television dates back to the early days of color transmission. This scheme encodes the color difference information onto a color subcarrier. The instantaneous phase of the subcarrier is the color's hue, and the amplitude is the color's saturation or intensity. This subcarrier is then added onto the existing luminance video signal. This trick works because the subcarrier is set at a high enough frequency to leave spectrum for the luminance information. But it is not a seamless matter to pull the signal apart again at the destination in order to display it or process it. The resultant artifacts of

dot crawl (also referred to as chroma crawl) are only the most obvious result. Composite television is the most commonly used format throughout the world, either as PAL or NTSC. It is also referred to as Encoded video.

Color Difference

Color Difference systems take advantage of the details of human vision. We have more acuity in our black and white vision than we do in color. This means that we need only the luminance information to be carried at full bandwidth, we can scrimp on the color channels. In order to do this, RGB information is converted to carry all of the luminance (Y is the black and white of the scene) in a single channel. The other two channels are used to carry the "color difference". Noted as B-Y and R-Y, these two signals describe how a particular pixel "differs" from being purely black and white. These channels typically have only half the bandwidth of the luminance.

Decibel (dB)

The decibel is a unit of measure used to express the ratio in the amplitude or power of two signals. A difference of 20 dB corresponds to a 10:1 ratio between two signals, 6 dB is approximately a 2:1 ratio. Decibels add while the ratios multiply, so 26 dB is a 20:1 ratio, and 14 dB is a 5:1 ratio. There are several special cases of the dB scale, where the reference is implied. Thus, dBm refers to power relative to 1 milliwatt, and dBu refers to voltage relative to .775V RMS. The original unit of measure was the Bel (10 times bigger), named after Alexander Graham Bell.

dBFS

In Digital Audio systems, the largest numerical value that can be represented is referred to as Full Scale. No values or audio levels greater than FS can be reproduced because they would be clipped. The nominal operating point (roughly corresponding to 0 VU) must be set below FS in order to have headroom for audio peaks. This operating point is described relative to FS, so a digital reference level of -20 dBFS has 20 dB of headroom before hitting the FS clipping point.

DVI

Digital Visual Interface. DVI-I (integrated) provides both digital and analog connectivity. The larger group of pins on the connector are digital while the four pins on the right are analog.

EDH

Error Detection and Handling is a method to verify proper reception of an SDI or HD-SDI signal at the destination. The originating device inserts a data packet in the vertical interval of the SDI signal and every line of the HD signal which contains a checksum of the entire video frame. This checksum is formed by adding up the numerical values of all of the samples in the frame, using a complex formula. At the destination this same formula is applied to the incoming video and the resulting value is compared to the one included in the transmission. If they match, then the content has all arrived with no errors. If they don't, then an error has occurred.

Embedded Audio

Digital Audio can be carried along in the same bitstream as an SDI or HD-SDI signal by taking advantage of the gaps in the transmission which correspond to the horizontal and vertical intervals of the television waveform. This technique can be very cost effective in transmission and routing, but can also add complexity to signal handling issues because the audio content can no longer be treated independently of the video.

Eye Pattern

To analyze a digital bitstream, the signal can be displayed visually on an oscilloscope by triggering the horizontal timebase with a clock extracted from the stream. Since the bit positions in the stream form a very regular cadence, the resulting display will look like an eye – an oval with slightly pointed left and right ends. It is easy to see from this display if the eye is “open”, with a large central area that is free of negative or positive transitions, or “closed” where those transitions are encroaching toward the center. In the first case, the open eye indicates that recovery of data from the stream can be made reliably and with few errors. But in the closed case data will be difficult to extract and bit errors will occur. Generally it is jitter in the signal that is the enemy of the eye.

Frame Sync

A Frame Synchronizer is used to synchronize the timing of a video signal to coincide with a timing reference (usually a color black signal that is distributed throughout a facility). The synchronizer accomplishes this by writing the incoming video into a frame buffer memory under the timing direction of the sync information contained in that video. Simultaneously the memory is being read back by a timing system that is genlocked to a house reference. As a result, the timing or alignment of the video frame can be adjusted so that the scan of the upper left corner of the image is happening simultaneously on all sources. This is a requirement for both analog and digital systems in order to perform video effects or switch glitch-free in a router. Frame synchronization can only be performed within a single television line standard. A synchronizer will not convert an NTSC signal to a PAL signal, it takes a standards converter to do that.

Frequency Response

A measurement of the accuracy of a system to carry or reproduce a range of signal frequencies. Similar to Bandwidth.

H.264

The latest salvo in the compression wars is H.264 which is also known as MPEG-4 Part 10. MPEG-4 promises good results at just half the bit rate required by MPEG-2.

HD

High Definition. This two letter acronym has certainly become very popular. Here we thought it was all about the pictures – and the radio industry stole it.

HDMI

The High Definition Multimedia Interface comes to us from the consumer marketplace where it is becoming the de facto standard for the digital interconnect of display devices to audio and video

sources. It is an uncompressed, all-digital interface that transmits digital video and eight channels of digital audio. HDMI is a bit serial interface that carries the video content in digital component form over multiple twisted-pairs. HDMI is closely related to the DVI interface for desktop computers and their displays.

IEC

The International Electrotechnical Commission provides a wide range of worldwide standards. They have provided standardization of the AC power connection to products by means of an IEC line cord. The connection point uses three flat contact blades in a triangular arrangement, set in a rectangular connector. The IEC specification does not dictate line voltage or frequency. Therefore, the user must take care to verify that a device either has a universal input (capable of 90 to 230 volts, either 50 or 60 Hz), or that a line voltage switch, if present, is set correctly.

Interlace

Human vision can be fooled to see motion by presenting a series of images, each with a small change relative to the previous image. In order to eliminate the flicker, our eyes need to see more than 30 images per second. This is accomplished in television systems by dividing the lines that make up each video frame (which run at 25 or 30 frames per second) into two fields. All of the odd-numbered lines are transmitted in the first field, the even-numbered lines are in the second field. In this way, the repetition rate is 50 or 60 Hz, without using more bandwidth. This trick has worked well for years, but it introduces other temporal artifacts. Motion pictures use a slightly different technique to raise the repetition rate from the original 24 frames that make up each second of film—they just project each one twice.

IRE

Video level is measured on the IRE scale, where 0 IRE is black, and 100 IRE is full white. The actual voltages that these levels correspond to can vary between formats.

ITU-R 601

This is the principal standard for standard definition component digital video. It defines the luminance and color difference coding system that is also referred to as 4:2:2. The standard applies to both PAL and NTSC derived signals. They both will result in an image that contains 720 pixels horizontally, with 486 vertical pixels in NTSC, and 576 vertically in PAL. Both systems use a sample clock rate of 27 MHz, and are serialized at 270 Mb/s.

Jitter

Serial digital signals (either video or audio) are subject to the effects of jitter. This refers to the instantaneous error that can occur from one bit to the next in the exact position of each digital transition. Although the signal may be at the correct frequency on average, in the interim it varies. Some bits come slightly early, others come slightly late. The measurement of this jitter is given either as the amount of time uncertainty or as the fraction of a bit width. For 270 Mb/s SD video, the allowable jitter is 740 picoseconds, or 0.2 UI (Unit Interval – one bit width). For 1.485 Gb/s HD, the same 0.2UI spec corresponds to just 135 pico seconds.

Luminance

The “black & white” content of the image. Human vision had more acuity in luminance, so television systems generally devote more bandwidth to the luminance content. In component systems, the luminance is referred to as Y.

MPEG

The Moving Picture Experts Group is an industry group that develops standards for the compression of moving pictures for television. Their work is an on-going effort. The understanding of image processing and information theory is constantly expanding. And the raw bandwidth of both the hardware and software used for this work is ever increasing. Accordingly, the compression methods available today are far superior to the algorithms that originally made the real-time compression and decompression of television possible. Today, there are many variations of these techniques, and the term MPEG has to some extent become a broad generic label.

Metadata

This word comes from the Greek, meta means ‘beyond’ or ‘after’. When used as a prefix to ‘data’, it can be thought of as ‘data about the data’. In other words, the metadata in a data stream tells you about that data – but it is not the data itself. In the television industry, this word is sometimes used correctly when, for example, we label as metadata the timecode which accompanies a video signal. That timecode tells you something about the video, i.e. when it was shot, but the timecode in and of itself is of no interest. But in our industry’s usual slovenly way in matters linguistic, the term metadata has also come to be used to describe data that is associated with the primary video in a datastream. So embedded audio will (incorrectly) be called metadata when it tells us nothing at all about the pictures. Oh well.

Multi-mode

Multi-mode fibers have a larger diameter core than single mode fibers (either 50 or 62.5 microns compared to 9 microns), and a correspondingly larger aperture. It is much easier to couple light energy into a multi-mode fiber, but internal reflections will cause multiple “modes” of the signal to propagate down the fiber. This will degrade the ability of the fiber to be used over long distances. See also Single Mode.

NTSC

The color television encoding system used in North America was originally defined by the National Television Standards Committee. This American standard has also been adopted by Canada, Mexico, Japan, Korea, and Taiwan. (This standard is referred to disparagingly as Never Twice Same Color.)

Optical

An optical interface between two devices carries data by modulating a light source. This light source is typically a laser or laser diode (similar to an LED) which is turned on and off at the bitrate of the datastream. The light is carried from one device to another through a glass fiber. The fiber’s core acts as a waveguide or lightpipe to carry the light energy from one end to another. Optical transmission has two very significant advantages over metallic copper cables. Firstly, it does not require that the two endpoint devices have any electrical connection to each other. This can be very advantageous in large facilities where problems with ground loops appear. And secondly, and most importantly, an

optical interface can carry a signal for many kilometers or miles without any degradation or loss in the recovered signal. Copper is barely useful at distances of just 1000 feet.

Oversampling

A technique to perform digital sampling at a multiple of the required sample rate. This has the advantage of raising the Nyquist Rate (the maximum frequency which can be reproduced by a given sample rate) much higher than the desired passband. This allows more easily realized anti-aliasing filters.

PAL

During the early days of color television in North America, European broadcasters developed a competing system called Phase Alternation by Line. This slightly more complex system is better able to withstand the differential gain and phase errors that appear in amplifiers and transmission systems. Engineers at the BBC claim that it stands for Perfection At Last.

Pathological Test Pattern – see Checkfield

Progressive

An image scanning technique which progresses through all of the lines in a frame in a single pass. Computer monitors all use progressive displays. This contrasts to the interlace technique common to television systems.

Return Loss

An idealized input or output circuit will exactly match its desired impedance (generally 75 ohms) as a purely resistive element, with no reactive (capacitive or inductive) elements. In the real world, we can only approach the ideal. So, our real inputs and outputs will have some capacitance and inductance. This will create impedance matching errors, especially at higher frequencies. The Return Loss of an input or output measures how much energy is returned (reflected back due to the impedance mismatch). For digital circuits, a return loss of 15 dB is typical. This means that the energy returned is 15 dB less than the original signal. In analog circuits, a 40 dB figure is expected.

RGB

RGB systems carry the totality of the picture information as independent Red, Green, and Blue signals. Television is an additive color system, where all three components add to produce white. Because the luminance (or detail) information is carried partially in each of the RGB channels, all three must be carried at full bandwidth in order to faithfully reproduce an image.

Sch Phase

Used in composite systems, Sch Phase measures the relative phase between the leading edge of sync on line 1 of field 1 and a continuous subcarrier sinewave. Due to the arithmetic details of both PAL and NTSC, this relationship is not the same at the beginning of each frame. In PAL, the pattern repeats every 4 frames (8 fields) which is also known as the Bruch Blanking sequence. In NTSC, the repeat is every 2 frames (4 fields). This creates enormous headaches in editing systems and the system timing of analog composite facilities.

Setup

In the NTSC Analog Composite standard, the term Setup refers to the addition of an artificial offset or pedestal to the luminance content. This places the Black Level of the analog signal 54 mV (7.5 IRE) positive with respect to ground. The use of Setup is a legacy from the early development of television receivers in the vacuum tube era. This positive offset helped to prevent the horizontal retrace of the electron beam from being visible on the CRT, even if Brightness and Contrast were mis-adjusted. While the use of Setup did help to prevent retrace artifacts, it did so at the expense of dynamic range (contrast) in the signal because the White Level of the signal was not changed.

Setup is optional in NTSC systems, but is never used in PAL systems (see 'Perfection' characteristic of PAL). This legacy of Setup continues to persist in North American NTSC systems, while it has been abandoned in Japan.

In the digital component world (SD and HD SDI) there is obviously no need for, and certainly every reason to avoid, Setup. In order for the interfaces between analog and digital systems to operate as transparently as possible, Setup must be carefully accounted for in conversion products. When performing analog to digital conversion, Setup (if present) must be removed and the signal range gained up to account for the 7.5% reduction in dynamic range. And when a digital signal is converted back to analog form, Setup (if desired on the output) must be created by reducing the dynamic range by 7.5% and adding the 54 mV positive offset. Unfortunately, there is no truly foolproof algorithm to detect the presence of Setup automatically, so it's definitely a case of installer beware.

SDI

Serial Digital Interface. This term refers to inputs and outputs of devices that support serial digital component video. This could refer to standard definition at 270 Mb/s, HD SDI or High Definition Serial Digital video at 1.485 Gb/s, or to the newer 3G standard of High Definition video at 2.97 Gb/s.

SMPTE

The Society of Motion Picture and Television Engineers is a professional organization which has done tremendous work in setting standards for both the film and television industries. The term "SMPTE" is also shorthand for one particular component video format - luminance and color difference.

Single Mode

A Single mode (or mono mode) optical fiber carries an optical signal on a very small diameter (9 micron) core surrounded with cladding. The small diameter means that no internally reflected lightwaves will be propagated. Thus only the original "mode" of the signal passes down the fiber. A single mode fiber used in an optical SDI system can carry a signal for up to 20 kilometers. Single mode fibers require particular care in their installation due to the extremely small optical aperture that they present at splice and connection points. See also Multi-mode.

TBC

A Time Base Corrector is a system to reduce the Time Base Error in a signal to acceptable levels. It accomplishes this by using a FIFO (First In, First Out) memory. The incoming video is written into the memory using its own jittery timing. This operation is closely associated with the actual digitization of the analog signal because the varying position of the sync timing must be mimicked by the sampling function of the analog to digital converter. A second timing system, genlocked to a stable reference,

is used to read the video back out of the memory. The memory acts as a dynamically adjusting delay to smooth out the imperfections in the original signal's timing. Very often a TBC will also function as a Frame Synchronizer. See also Frame Sync.

Time Base Error

Time base error is present when there is excessive jitter or uncertainty in the line to line output timing of a video signal. This is commonly associated with playback from video tape recorders, and is particularly severe with consumer type heterodyne systems like VHS. Time base error will render a signal unusable for broadcast or editing purposes.

Timecode

Timecode, a method to uniquely identify and label every frame in a video stream, has become one of the most recognized standards ever developed by SMPTE. It uses a 24 hour clock, consisting of hours, minutes, seconds, and television frames. Originally recorded on a spare audio track, this 2400 baud signal was a significant contributor to the development of video tape editing. We now refer to this as LTC or Longitudinal Time Code because it was carried along the edge of the tape. This allowed it to be recovered in rewind and fast forward when the picture itself could not. Timecode continues to be useful today and is carried in the vertical interval as VITC, and as a digital packet as DVITC. Timecode is the true metadata.

Tri-Level Sync

For many, many years, television systems used composite black as a genlock reference source. This was a natural evolution from analog systems to digital implementations. With the advent of High Definition television, with even higher data rates and tighter jitter requirements, problems with this legacy genlock signal surfaced. Further, a reference signal with a 50 or 60 Hz frame rate was useless with 24 Hz HD systems running at film rates. Today we can think of composite black as a bi-level sync signal – it has two levels, one at sync tip and one at blanking. For HD systems, Tri-Level Sync, which has the same blanking level (at ground) of bi-level sync, but the sync pulse now has both a negative and a positive element. This keeps the signal symmetrically balanced so that its DC content is zero. And it also means that the timing pickoff point is now at the point where the signal crosses blanking and is no longer subject to variation with amplitude. This makes Tri-Level Sync a much more robust signal and one which can be delivered with less jitter.

USB

The Universal Serial Bus, developed in the computer industry to replace the previously ubiquitous RS-232 serial interface, now appears in many different forms and with many different uses. It actually forms a small local area network, allowing multiple devices to coexist on a single bus where they can be individually addressed and accessed.

VGA

Video Graphics Array. Traditional 15-pin, analog interface between a PC and monitor.

Word Clock

Use of Word Clock to genlock digital audio devices developed in the audio recording industry. Early digital audio products were interconnected with a massive parallel connector carrying a twisted pair

for every bit in the digital audio word. A clock signal, which is a square wave at the audio sampling frequency, is carried on a 75 ohm coaxial cable. Early systems would daisychain this 44.1 or 48 kilohertz clock from one device to another with coax cable and Tee connectors. On the rising edge of this Word Clock these twisted pairs would carry the left channel, while on the falling edge, they would carry the right channel. In most television systems using digital audio, the audio sample clock frequency (and hence the 'genlock' between the audio and video worlds) is derived from the video genlock signal. But products that are purely audio, with no video reference capability, may still require Word Clock.

WSS

Wide Screen Signaling is used in the PAL/625 video standards, both in analog and digital form, to convey information about the aspect ratio and format of the transmitted signal. Carried in the vertical interval, much like closed captioning, it can be used to signal a television receiver to adjust its vertical or horizontal sizing to reflect incoming material. Although an NTSC specification for WSS exists, it never achieved any traction in the marketplace.

YUV

Strictly speaking, YUV does not apply to component video. The letters refer to the Luminance (Y), and the U and V encoding axes using in the PAL composite system. Since the U axis is very close to the B-Y axis, and the V axis is very close to the R-Y axis, YUV is often used as a sort of shorthand for the more long-winded "Y/R-Y/B-Y".

Y/Cr/Cb

In digital component video, the luminance component is Y, and the two color difference signals are Cr (R-Y) and Cb (B-Y).

Y/Pr/Pb

In analog component video, the image is carried in three components. The luminance is Y, the R-Y color difference signal is Pr, and the B-Y color difference signal is Pb.