

AVENUE

Avenue® signal integration system

Model 7500 HD Video Processing Frame Synchronizer Data Pack

ENSEMBLE
DESIGNS

Revision 2.1 SW v2.2.0

This data pack provides detailed installation, configuration and operation information for the **7500 High Definition (HD) Video Processing Frame Synchronizer** module along with the **8415 Audio Processing** submodule as part of the Avenue Signal Integration System.

The module information in this data pack is organized into the following sections:

- 7500 Series Overview
- Applications
- Installation
- Cabling
- Module Configuration and Control
 - Front Panel Controls and Indicators
 - Avenue PC Remote Control
 - Avenue Touch Screen Remote Control
- Troubleshooting
- Software Updating
- Warranty and Factory Service
- Specifications

7500 OVERVIEW

The 7500 Video Processing Frame Synchronizer accepts a high definition video signal for processing, synchronization, and timing.

The module's main features are summarized below:

- HD SDI I/O
- Full-featured Frame Synchronizer
- Comprehensive Proc Amp Controls
- Target hue color processing controls
- Pixel by pixel Legalizer for Y, Cr, Cb or RGB requirements
- External genlock reference signal
- EDH detection and insertion
- Internal Test Signal Generator
- Automatic Standard Detection
- Memory Registers
- Accepts the 8415 Audio Processor submodule option for tracking audio delay, audio mixing, and shuffling

The 7500 modules provides flexible synchronization with an infinitely adjustable timing system that genlocks to your house reference. The module will genlock to either composite video (PAL or NTSC) or to HD Tri-level Sync. It can also lock to the frame's master reference or a reference can be connected directly to the module's external reference BNC. The serial output timing can be set anywhere within a frame of the selected input reference. Frame delay for an asynchronous input can be set for up to 3 frames.

Upon loss of signal, the 7500 provides freeze frame or black on the output until the signal is recovered. In freeze mode, audio can be muted or passed as desired.

The HD input is carried at full, uncompressed bandwidth throughout the entire module for uncompromised picture quality. EDH monitoring of the digital input is provided to alert the user to an incoming problem. EDH detection, monitoring and insertion are standard on the 7500. Flags are reported through the Avenue PC application.

As shown in the block diagram on the following page, the 7500 has a full-featured Proc Amp with adjustment for every signal parameter. Video Proc controls include video and chroma gain, NTSC style hue rotation, black balance and pedestal.

Part of the video processing includes a color processor that provides controls for targeting a particular hue in a scene you wish to change. These controls allow you to target the color, adjust the amount of sensitivity then adjust luminance, chrominance, pedestal and hue for only the targeted color without affecting any other color in the scene.

A Legalizer can be enabled that will inhibit the picture on a pixel by pixel basis to be within legal limits for RGB requirements. A Y, Cr, Cb legalizer provides clip controls for adjusting the picture white and black clipping and chroma limiting as desired for your application.

An 8415 Audio Processor submodule can be installed on the 7500 module. The 8415 is an eight channel processor designed to provide superior handling of embedded audio. The disembedder on the input side follows the timing of the HD input, even if that input is asynchronous to the house reference. The embedder on the output side is synchronous to house. This allows embedded audio to be safely bypassed around the video Framestore to properly preserve re-synchronized embedded audio for correct lip sync. The 7500 and 8415 combination can serve as a dedicated HD embedder or HD disembedder. The Control modules in the frame (5030 or 5035) must be running software version 2.0.5 or later for proper operation of the 8415.

Every function and parameter on the 7500 and 8415 can be controlled from an Express Panel, Avenue Touch Panel, or the Avenue PC Control Application. Memory registers can be used to save the complete configuration of the module, making it easy to change instantly between different configurations.

Ten 7500 Video Processors (including the 8415 Audio option can be accommodated by the Avenue 3 RU frame or four modules can be installed in the 1 RU frame.

Modules at software version 2.2.0 or later support SNMP (Simple Network Management Protocol) monitoring. For each applicable signal processing module, module, signal, and reference status are reported. For complete details on using SNMP monitoring, refer to the **Avenue System Overview** in the manual that accompanies each frame.

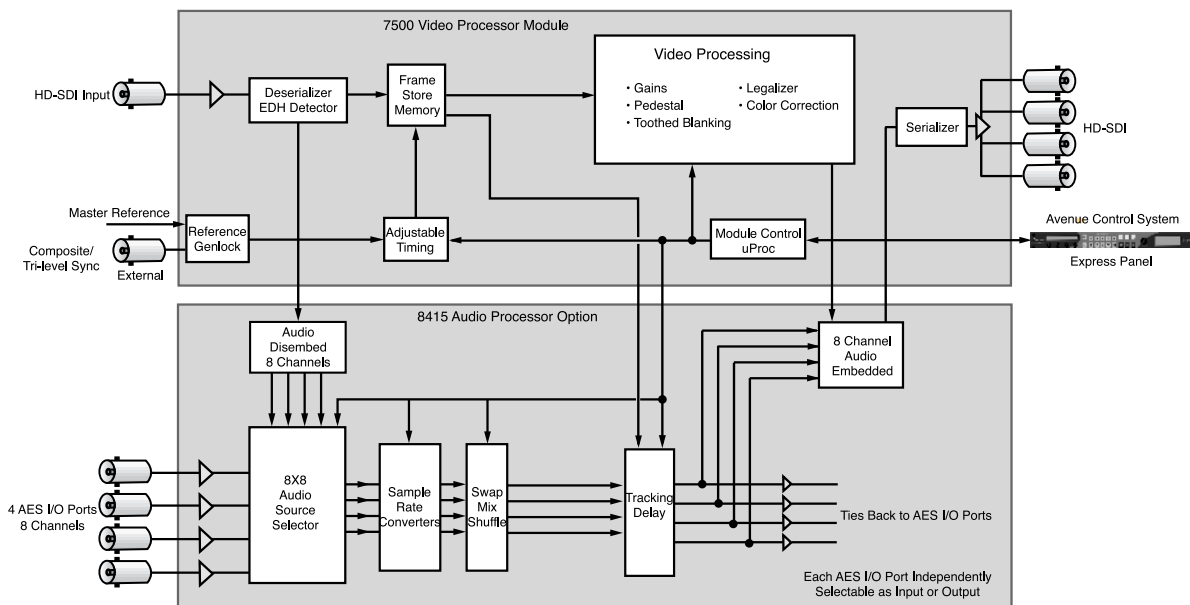

7500 with 8415 Functional Block Diagram

APPLICATIONS

This section provides two typical applications for utilizing the full versatility of the 7500 Video Processor module and the optional 8415 submodule.

Timing of an Asynchronous Input

As shown in the illustration below, the 7500 module with an 8415 audio submodule can accept an asynchronous video input such as the feed from a satellite receiver. The module can time the signal to a house reference and send the timed output to a router for distribution throughout the facility. With the 8415 audio submodule installed, the audio lip sync of the input signal is preserved.

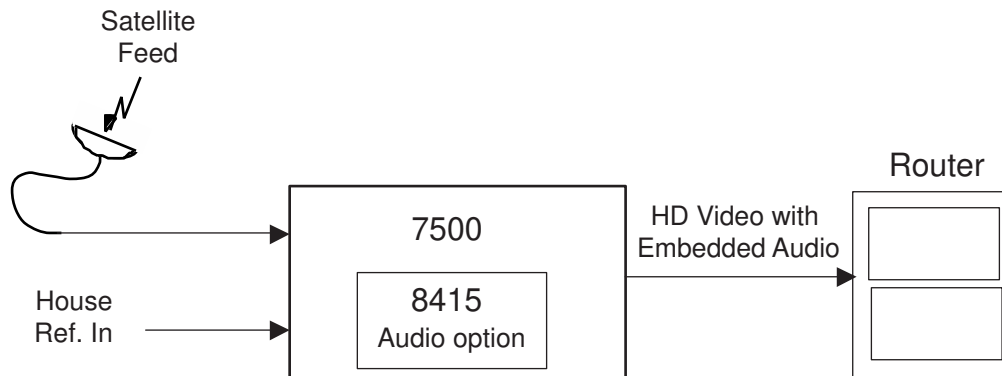

7500 Module Timing an Asynchronous Satellite Input Signal

Embedding AES Audio

In the example shown below, the 7500 module with an 8415 audio submodule is embedding AES audio into the HD SDI output of a production switcher. The Proc Amp on the 7500 is used to make final adjustments to the video which is then output to a video server.

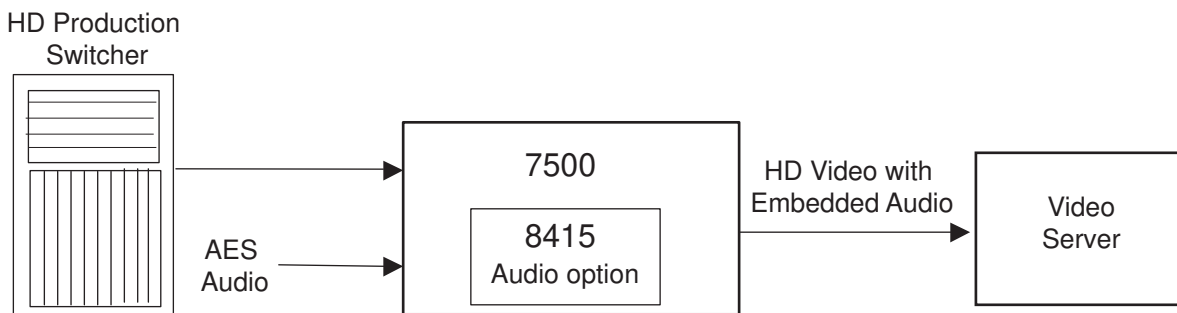

7500 Module Timing an Asynchronous Satellite Input Signal

INSTALLATION

8415 Submodule Installation

The optional 8415 Series submodule installs on the component side of the 7500 Video Processing module circuit board. If the option is ordered with the 7500 module, it will come already installed.

To install the 8415 audio submodule, locate the three connectors on the left side of the circuit board as shown below and line the connectors up, checking the alignment. Press carefully into place to seat the submodule.

Note: Operation of the 8415 Audio submodule requires that the Control module (5030/5035) in the frame be running version 2.0.5 software or later.

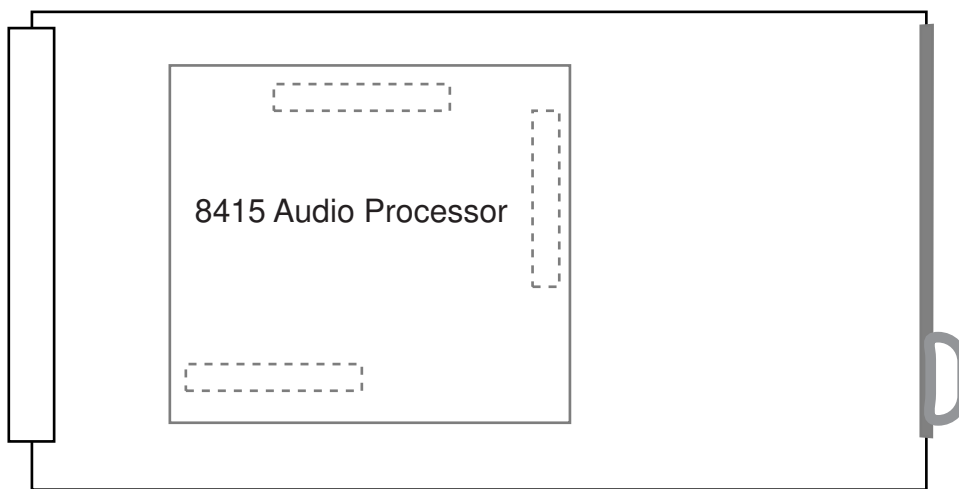

8415 Submodule Installation

7500 Video Processing Module

Plug the 7500 module into any one of the slots in the 1 RU or 3 RU frame and install the plastic overlay provided onto the corresponding group of rear BNC connectors associated with the module location. Note that the plastic overlay has an optional adhesive backing for securing it to the frame. Use of the adhesive backing is only necessary if you would like the location to be permanent and is not recommended if you need to change module locations. This module may be hot-swapped (inserted or removed) without powering down or disturbing performance of the other modules in the system.

CABLING

Refer to the 3 RU and 1 RU backplane diagrams of the module below for cabling instructions. Note that unless stated otherwise, the 1 RU cabling explanations are identical to those given in the 3 RU diagram.

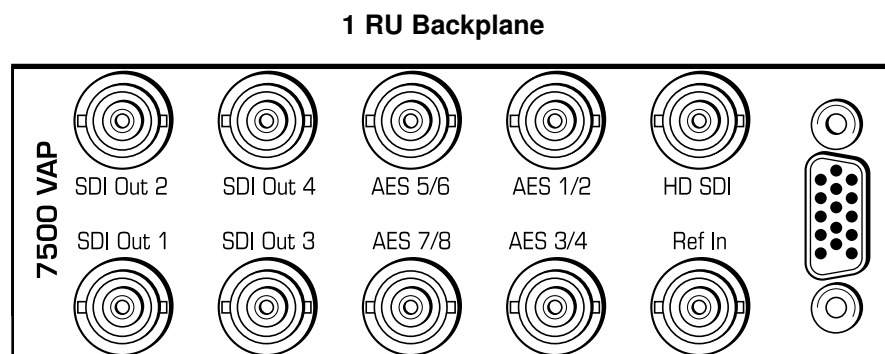
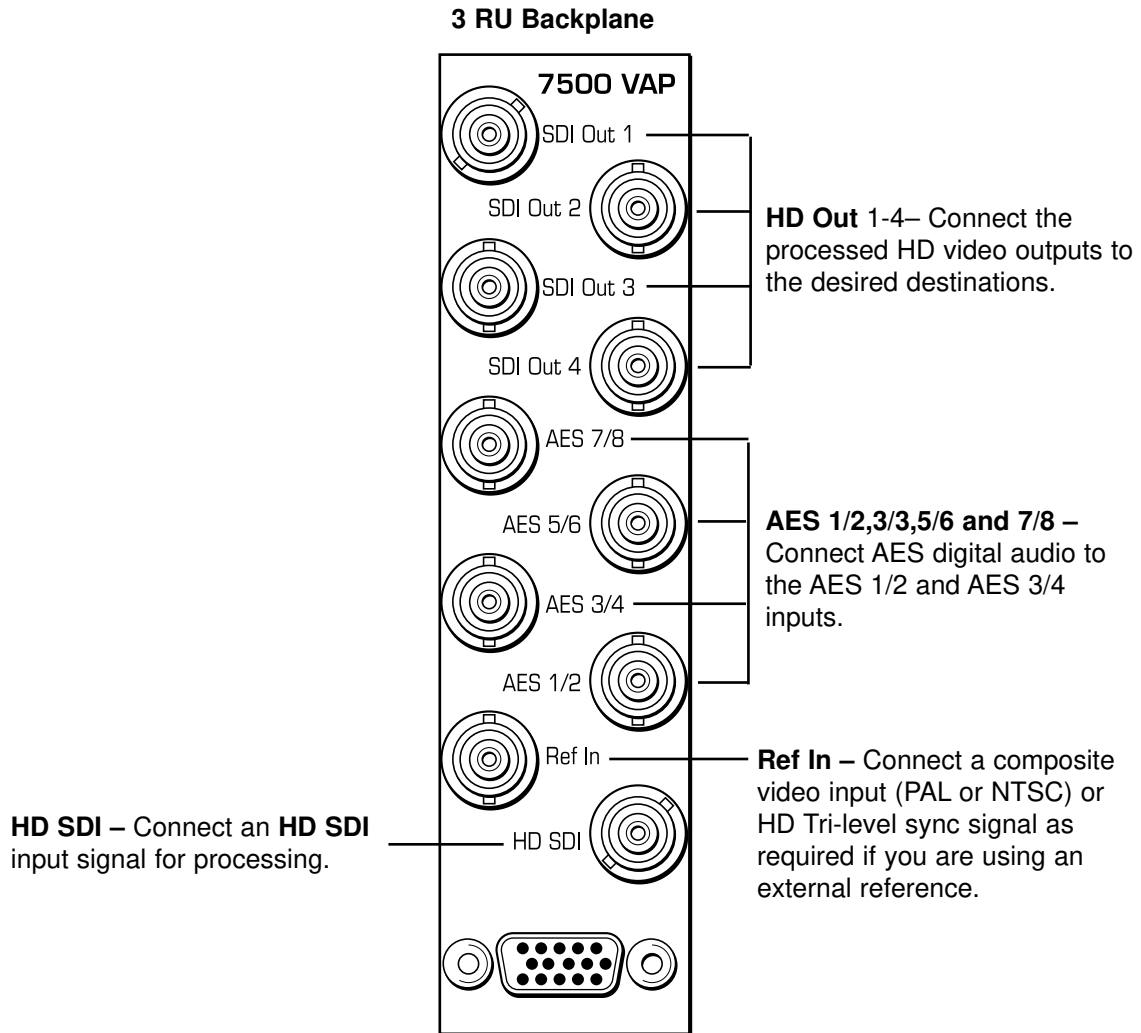

MODULE CONFIGURATION AND CONTROL

The configuration parameters for each Avenue module must be selected after installation. This can be done remotely using one of the Avenue remote control options or locally using the module front panel controls. Each module has a **Remote/Local** switch on the front edge of the circuit board which must first be set to the desired control mode.

The configuration parameter choices for the module will differ between **Remote** and **Local** modes. In **Remote** mode, the choices are made through software and allow more selections. The **7500 Parameter Table** later in this section summarizes and compares the various configuration parameters that can be set remotely or locally and the default/factory settings. It also provides the default User Levels for each control. These levels can be changed using the Avenue PC application

If you are not using a remote control option, the module parameters must be configured from the front panel switches. Parameters that have no front panel control will be set to a default value. The **Local** switches are illustrated in the **Front Panel Controls and Indicators** section following the **7500 Parameter Table**. The **Local** switches are inactive when the **Remote/Local** switch is in the **Remote** position.

In the **Remote** mode, Avenue module parameters can be configured and controlled from one or both of the remote control options, the Avenue Touch Screen or the Avenue PC Application. Once the module parameters have been set remotely, the information is stored on the module CPU. This allows the module to be moved to a different cell in the frame at your discretion without losing the stored information.

For setting the parameters remotely using the Avenue PC option, refer to the **Avenue PC Remote Configuration** section of this document.

For setting the parameters remotely using the Avenue Touch Screen option, refer to the **Avenue Touch Screen Remote Configuration** section of this document following Avenue PC.

For setting the parameters remotely using the Avenue Express Control Panel option, refer to the **Avenue Express Control Panel** data pack that comes with the panel option.

Configuration Summary

This section provides a general overview of the configuration for the 7500 module. The controls available for configuration with remote control are summarized and tips and examples are given for using particular controls to achieve the best results.

Video Processing

The 7500 has a full-featured Proc Amp for adjustment of every signal parameter. Proc controls adjust the overall video signal. A color processor menu allows for targeting a specific hue you may wish to change, then adjusting color processing parameters for the targeted hue without affecting other colors in the scene.. A Legalizer menu allows adjustment of black and white clips to prevent excessive signal excursions or the output can be set to meet default RGB values determined on a pixel by pixel basis.

The available video/color processing and video timing and output remote control menus are summarized below:

- **Proc:** Video Gain, Chroma, Pedestal and Hue are standard Proc Amp controls affecting the entire signal. The Hue control gives phase rotation of the color vectors in the manner of an NTSC composite Proc Amp.
- **Color Proc:** Use this control to target a particular color in a scene you wish to change. Use the Target Hue and Sensitivity adjustments to pinpoint the exact color to be adjusted. Then adjust the targeted color with the Luminance, Chroma, Pedestal, and Hue color processing controls without affecting any other colors in the scene.
- **Clip:** The Clip menu provides enabling of a Legalizer which insures signal levels will not exceed those permitted in the composite domain. Thus its use can insure a television transmitter will not be presented illegal video input. If set to Off or set for Legal RGB, adjustments are grayed out and may not be changed. When set to Y, Cr, Cb, controls for black and white clipping and chroma limiting are provided.
- **Timing:** The 7500's comprehensive range of timing allows complete flexibility in placement of the output picture relative to the applied reference input. A Frame Synchronizer can be enabled to allow timing the signal to an external house reference. Frame Delay can be set for up to three frame s of delay.
- **Video Out:** The Bypass selection takes the 7500 Proc Amp out of the video path by routing the signal around it to the output. One of four internally generated test signals may be selected to be sent to the output signal if needed. Embedded Audio is removed from the HD SDI stream when Strip is selected in the Strip Audio window. There are Wide, and Narrow vertical blanking choices. Wide gives blanking through line 20 (NTSC) or line 22 (PAL), while narrow produces blanking through line 9 (NTSC) or Line 6 (PAL) of both fields.
- **Trims:** Cb and Cr offsets allow black balance to be corrected while Cb and Cr gains permit trimming of levels on these two axes. Y/C delay allows the operator to correct inaccuracy of timing of color information relative to luminance. These trims are functional regardless of the input or output formats in use.
- **Memory:** Up to five configurations of the 7500 may be saved into memory registers for later recall. All parameters – gains, input format, filters, blanking, etc. - are saved in each memory. The 7500 for HD SDI Input can be used with audio disembedding, channel swapping and re-embedding in a particular application. In another application other audio parameters can be adjusted for a particular configuration. These two setups could be stored in memory registers and one or the other recalled for instant restoration of the required configuration.

8415 Audio Processor Configuration

The 8415 Audio Processor accepts audio from the AES input connectors and can disembed audio from the incoming HD SDI video stream.

Between the input and output is a 8x8 mixer with tracking audio delay. Any incoming audio can be mixed, level controlled and/or shuffled to another output channel by means of the integrated audio router. The tracking audio delay allows synchronization and timing to be maintained with time base corrected video passing through the video frame synchronizer of the 7500.

A built in sample rate converter allows use of asynchronous AES input signals. The Audio Processors also support encoded audio formats such as AC-3 and Dolby-E. Because these data streams cannot tolerate sample rate conversion, they must be input to the Audio Processors synchronous to the video. All audio processing is performed at the full 24 bit resolution of the system. At the output side of the submodule the eight audio channels may be simultaneously routed to AES output connectors while also being embedded on the outgoing SDI video. An adapter is also available to allow the AES I/O to be converted from BNC to 110 ohm balanced on the output.

The available audio processing remote control menus are summarized below:

- **Audio Mix:** This menu gives full access to the 8x8 audio mixer controls. Any input channel can be routed to any or all output busses. Sliders or Touch Screen rotary knobs permit levels to be adjusted from -70dB to +12dB. Alternatively a value can be put in the numeric window, followed by the Enter key, and this will become the new gain setting. Default buttons are provided for return to zero level.

The Tie function is used for stereo operation where gain of a pair of channels is usually desired to be the same. An invert selection allows inversion of a channel to permit phase correction.

- **Audio In:** Status indicators show presence of AES and embedded (HD SDI) audio inputs. The Audio In A and Audio In B menus allow selection of inputs to the audio mixer. The choices for the 8415 are AES 1/2, AES 3/4, AES 5/6 and AES 7/8 and SDI 1/2, SDI 3/4, SDI 5/6, and SDI 7/8. Thus any pair of input audio signals can be routed to either pair of input buses of the output audio mixer.
- **Audio Mode:** The Audio Mode control is provided to allow an HD SDI input with embedded audio to operate in Audio (normal) or Data (non-audio). The 7500 can handle both types of content present in AC-3 or Dolby_E signals. Some synchronizing requirements are necessary for supporting these protocols.

Select the **Audio** mode when the input audio signal is a standard audio signal carrying two channels of linear audio. No special timing requirements are needed in this mode.

Use the **Data** mode when the serial digital audio is a non-audio, or data, signal. Some special synchronizing requirements must be observed in this mode as described in the following examples.

HD SDI Signal with embedded data – For this case, if an HD SDI signal with embedded data is applied to the input, the content will be handled by passing through the 7500 frame store memory to the output of the 7500. No audio submodule is required. The audio input signal in this case is synchronous to the timing reference. This is normal operation of the 7500 and no special configuration is necessary.

Data mode signal to be disembedded and output as an AES stream –

This mode requires the use of an audio submodule to disembed the de-serialized SDI input and route the channels to the correct path. If one of the channels is normal audio, it can be mixed, swapped, shuffled, and delayed by the audio submodule. If the other channel is non-audio data, it bypass the normal audio functions and is carried to the AES output formatter and driver.

When in the Data mode, the AES formatter is driven by the output timing of the 7500, the original SDI input must be synchronous to the reference input or the 7500 must be configured to use the SDI signal as the timing reference.

Data mode signal to be disembedded, output as AES, then re-

embedded – In this case the audio submodule is also required. This case is similar to the one above, while the disembedded data is re-embedded in the HD SDI output of the 7500. The same timing requirements apply.

Original embedded data to be left unchanged with an additional

embedded group to be added – The original embedding in the HD SDI input passes through the 7500 processing path. At the same time, an audio submodule is used to create a second embedded group which is placed in cascade, following the original audio group which contains the data mode signal.

A data mode signal in AES format is input to the audio submodule –

This example could be used when there is a need to embed the AES data into the output of the 7500. In this case the AES data input must be synchronous. When being used in this manner, the audio submodule can embed data mode AES into one pair of channels in an embedded group, while embedding conventional audio into the other pair.

- **Audio Delay:** With the Auto Track switched On, audio will be delayed the same amount as the video passing through the 7500 frame synchronizer thus preserving lip sync. If incoming audio is early due to signals passing through an upstream frame sync without a compensating audio delay, Bulk Delay can be used to correct the problem. Up to 1000 mS of fixed delay can be added to compensate for upstream timing errors.

7500 Parameter Table

CONTROL	LOCAL	REMOTE	DEFAULT	USER LEVEL
VIDEO AND COLOR PROCESSING				
Ref Source		Ext Ref Master Ref Video In Ref	Ext Ref	Admin
Proc Amp Gain	100%	0 to 150%	100%	Admin
Proc Amp Chroma	100%	0 to 150%	100%	Admin
Proc Amp Pedestal	0 IRE	+/- 30 IRE	0 IRE	Admin
Proc Amp Hue	0 degrees	+/- 180 degrees	0 degrees	Admin
Color Proc Target Hue	0 degrees	0 to 360 degrees	0 degrees	Admin
Color Proc Selectivity	0	0 to 100	0	Admin
Color Proc Luminance	0	0 to 150%	0	Admin
Color Proc Pedestal	0 IRE	+/- 20 IRE	0 IRE	Admin
Color Proc Hue	0 degrees	+/- 180 degrees	0 degrees	Admin
Legalizer	Switch 2 Legalizer: On or Off	Off Y-Cr-Cb Legal RGB	Off	Admin
B/W Clip	Off	Off On	Off	Admin
Black Clip	- 8 IRE	- 8 to 6.2 IRE	- 8 IRE	Admin
White Clip	110 IRE	95 to 110 IRE	110 IRE	Admin
Chroma Limit	85%	85 to 125%	85%	Admin
Frame Sync	Switch 1 Frame Sync: On or Off (Ext Ref only)	Off On	On	Admin
Frame Delay	0 frames	0 to 3 frames	0 frames	Admin
Timing	0 lines	+/- 1200 lines	0 lines	Admin

7500 Parameter Table (Continued)

CONTROL	LOCAL	REMOTE	DEFAULT	USER LEVEL
VIDEO OUTPUT CONTROLS				
Bypass	Normal	Normal Bypass	Normal	Admin
Strip Audio	Off	Off On	Off	Admin
Test Pattern	Off	Off Bars Black Pathological Unit Circle	Off	Admin
Signal Mute	No Muting	No Muting Mutes on Noise Freeze on Noise	No Muting	Level 1
BLANKING and TRIM CONTROLS				
Vert Blanking	Wide	Wide (PAL Lines 1-22< NTSC Lines 1-20) Narrow (PAL Lines 1-6< NTSC Lines 1-9)	Wide	Admin
Cb Offset	0 IRE	+/- 100 IRE	0 IRE	Admin
Cr Offset	0 IRE	+/- 100 IRE	0 IRE	Admin
Cb Gain	0 IRE	+/- 20 IRE	0 IRE	Admin
Cr Gain	0 IRE	+/- 20 IRE	0 IRE	Admin

7500 Parameter Table (Continued)

CONTROL	LOCAL	REMOTE	DEFAULT	USER LEVEL
AUDIO CONTROLS (8415 Audio Submodule Installed)				
Input Level Ch 1 – Ch 8	0 dB	-70 to +12 dB	0 dB	Level 1
Ch 1-8 Output Bus	Ch 1 – Output 1 Ch 2 – Output 2 Ch 3 – Output 3 Ch 4 – Output 4 Ch 5 – Output 5 Ch 6 – Output 6 Ch 7 – Output 7 Ch 8 – Output 8	Output Bus 1 – 8	Ch 1 – Output 1 Ch 2 – Output 2 Ch 3 – Output 3 Ch 4 – Output 4 Ch 5 – Output 5 Ch 6 – Output 6 Ch 7 – Output 7 Ch 8 – Output 8 Tie	Level 1
1/2 Input 3/4 Input 5/6 Input 7/8 Input	Switch 8: AES or Embed	AES 1/2 AES 3/4 AES 5/6 AES 7/8 SDI 1/2 SDI 3/4 SDI 5/6 SDI 7/8	AES 1/2	Level 1
1/2, 3/4, 5/6, 7/8 Mode	Auto	Audio Data Auto	Auto	Level 1
DeMux Group	Group 1	Group 1 Group 2 Group 3 Group 4	Group 1	Level 1
Auto Track	On	Off On	On	Level 1
Bulk Delay	0 msec	0 – 1000 msec	0 msec	Level 1
Audio Embed	Replace	Off Replace Cascade	Replace	Level 1
Mux Group A and B	Group 1	Group 1 Group 2 Group 3 Group 4	Group 1	Level 1
Dig Ref Level	-20 dBFS	-20 dBFS -18 dBFS	-20 dBFS	Level 1

Front Panel Controls and Indicators

Each front edge indicator and switch setting is shown in the diagram below:

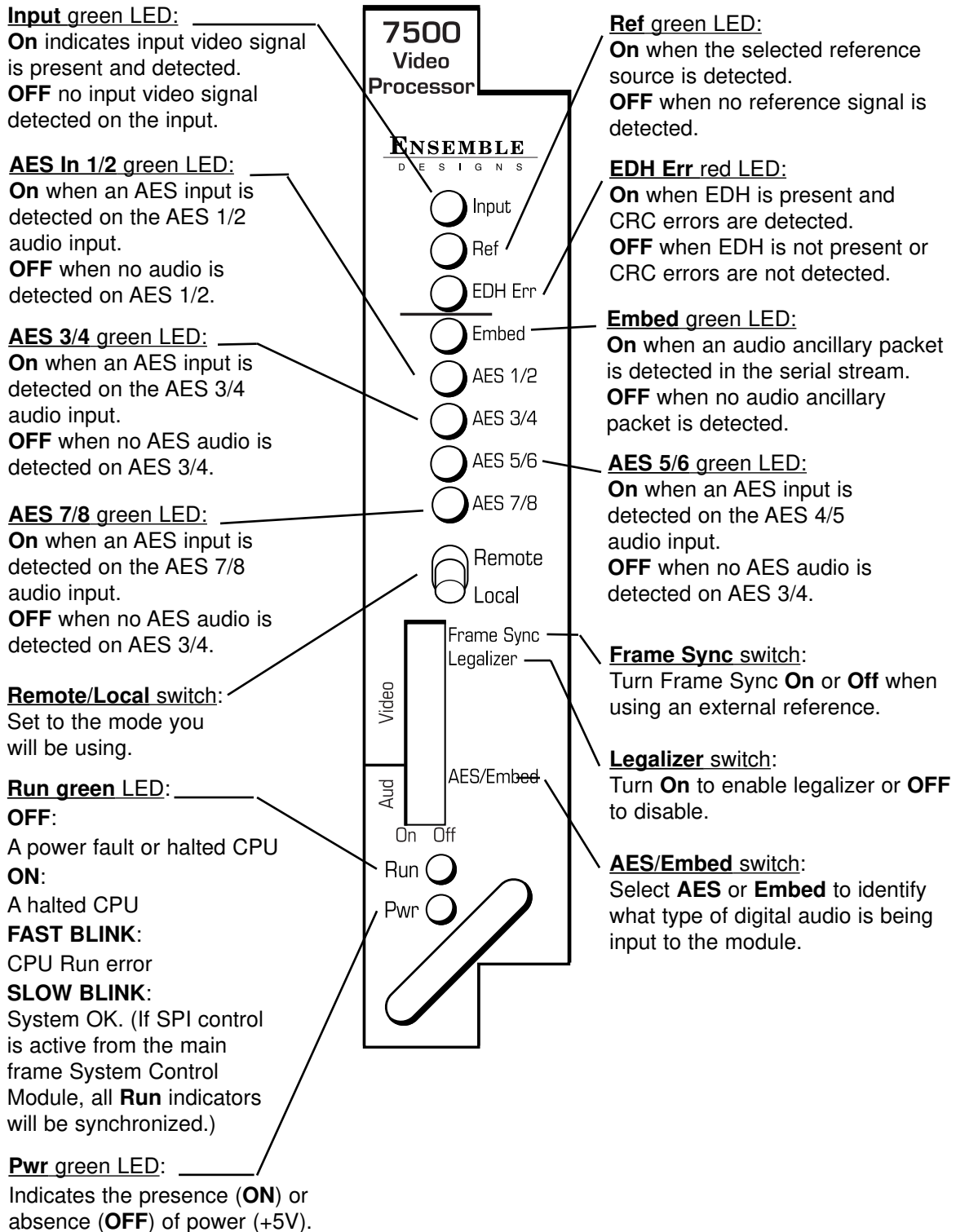

Avenue PC Remote Configuration

The Avenue PC remote control menus for this module are illustrated and explained below. Refer to the **7500 Parameter Table** for a summary of available parameters that can be set remotely through the menus illustrated. The **Configuration Summary** gives tips and general background information on setting the parameters. For more information on using Avenue PC, refer to the Avenue PC Control Application Software data pack.

Parameter fields that are grayed out can indicate one of the following conditions:

- An option is not installed.
- The function is not active.
- The module is locked.
- The User Level set with Avenue PC is not accessible from the current User Level.

7500 Avenue PC Menus

The **Vid In** menu shown below allows you to configure the following input sources:

- **Ref Source** – use this control to set the reference input source.

Status reporting is provided for the following conditions:

- **Input** – reports the input status as **No Input**, **720p/50**, **720p/59.94**, **1080i/50**, **1080i/59.94**, **1080p/25**, **1080p/23.98**, **1080sF/25**, **1080sF/23.98**, or **Unknown Std.**
- **Input Error** – reports one of the following errors: **No Error**, **No Input Lock**, **EDH/CRC Error**, and **TRS Error**.
- **Error Seconds** – displays the number of seconds that a detected EDH error has been present in the serial data stream.
- **Reference** – reports the status of the reference input as either **No Reference**, **Ref Mismatch**, **Ref Unlocked**, **Ref 525 Lock**, **Ref 625 Lock**, or **TLS Lock**.

Aud Delay		Aud Out		Timing		Vid Out		Memory		Trim	
Vid In	Proc	Color Proc	Clip	Aud Mix A	Aud Mix B	Aud In A	Aud In B				
Input			Input Error			Error Seconds					
No Input			No Input Lock			0 Cnt					
Ref Source				Reference							
Master Ref				Ref 525 Lock							

Model 7500 HD Video Frame Sync

The **Proc** menu shown below allows you to adjust the following video processing parameters for the signal:

- **Gain** – adjust the percentage of overall gain (luminance and chrominance).
- **Chroma** – adjust the percentage of chroma amplitude.
- **Pedestal** – adjust the pedestal (black) level of the signal in IRE.
- **Hue** – adjust the hue of the signal ± 180 degrees.

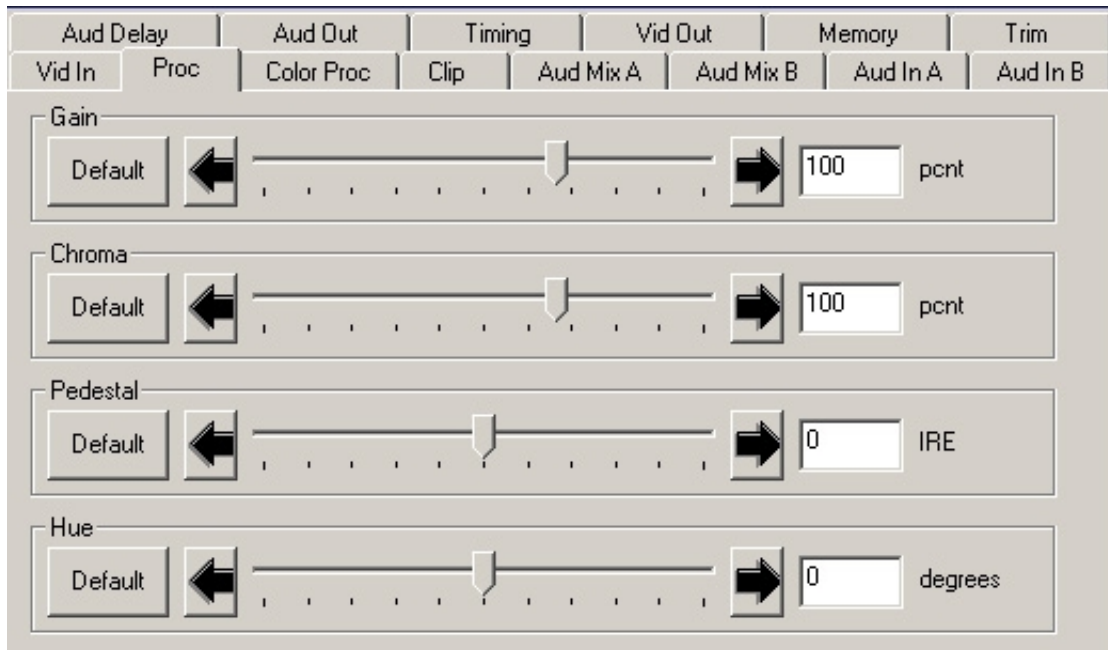

The **Color Proc** menu shown below allows you to select a target hue and adjust color correction parameters for the selected target color without disturbing other colors in the scene.

Note: If not using this menu for color processing, make sure all color proc parameters are set for default values.

- **Target Hue** – use to select a particular hue to change with the Color proc controls.
- **Selectivity** – use this control to adjust range of the target hue selected.

Tip: To help identify where to set the Target Hue and Selectivity, temporarily turn down the Luminance or Chroma control below. Rotate the Target Hue and adjust the Sensitivity until you can determine the exact color area you wish to change. Return the Luminance or Chroma control to 100% once the Target Hue and Selectivity controls are set for the correct color.

- **Luminance** – once the Target Hue has been identified, adjust the percentage of overall lightness and darkness for the targeted hue.
- **Pedestal** – adjust the pedestal (black) level of the signal if necessary in IRE.
- **Chroma** – once the Target Hue has been identified, adjust the percentage of overall color saturation for the targeted hue.
- **Hue** – adjust the hue of the signal \pm 180 degrees.

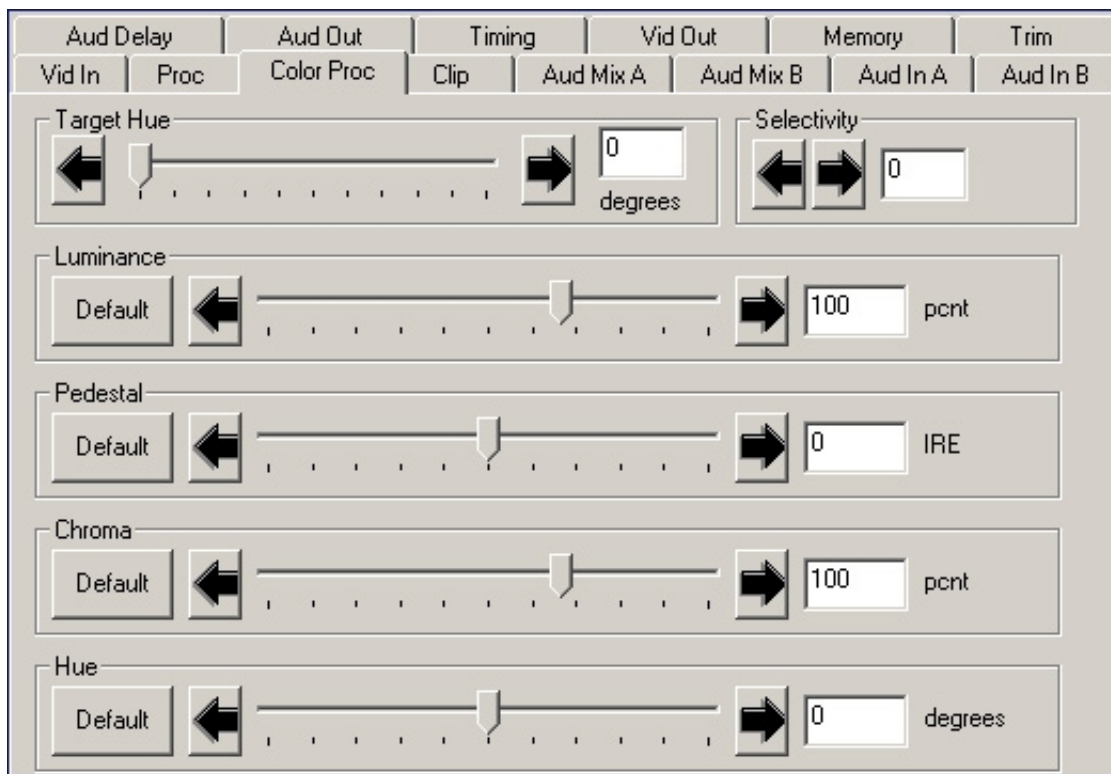

Use the **Clip** menu shown below to enable or disable the **Legalizer** circuitry on the module which allows adjustment the following parameters:

- **Off** – for no Legalizer.
- **Y-Cr-Cb** – selecting this choice will enable the **Black** and **White Clip**, and **Chroma Limiting** controls.
 - **Black Clip** – set the threshold for the black clip level. (No content will be allowed below the level set.)
 - **White Clip** – set the threshold for the white clip. (No content will be allowed above the level set.)
 - **Chroma Limit** – adjust the percentage of chroma limiting desired for the output.
- **Legal RGB** – selecting this choice will set the module to default legal RGB parameters set on a pixel by pixel basis and will gray out the clip and chroma limit controls.

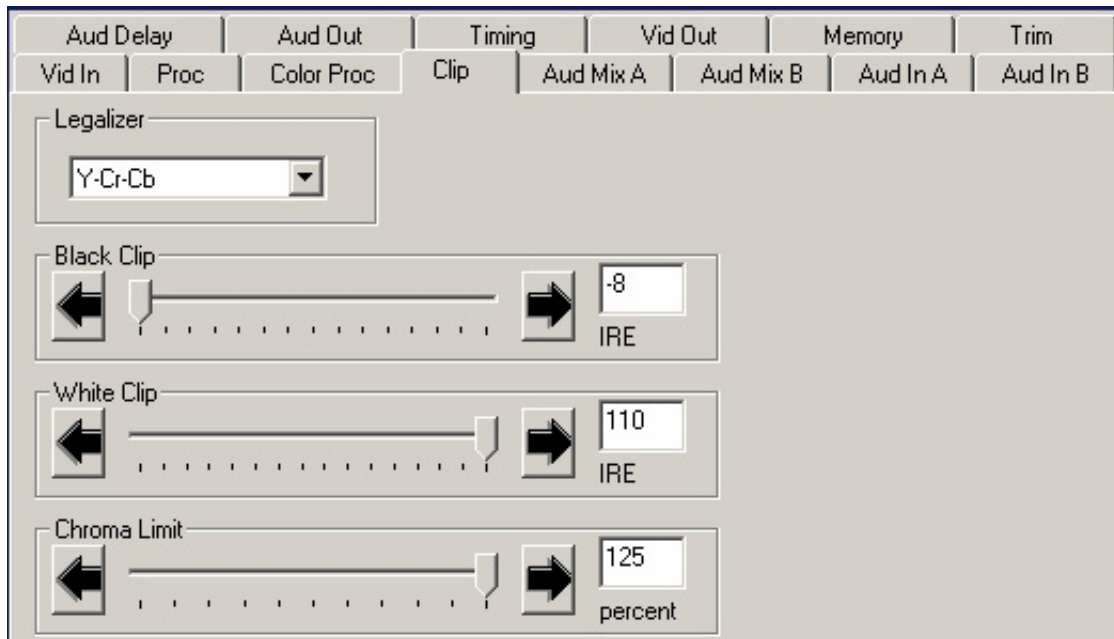

When an 8415 Audio Processor submodule is installed, use the **Aud Mix A** and **B** menus shown to control the audio input levels and mixing and shuffling of the audio inputs to output. Each output bus assignment will be indicated by a green box.

For Channels 1 –4, use the **Audio Mix A** menu to set the following

- **Input Ch 1** – assign Input Channel 1 to the desired output bus or tie to Channel 2. Set the input level using the slider control or by entering a number in the window and pressing the **Enter** key on your PC.
- **Input Ch 2** – assign Input Channel 2 to the desired output bus or tie to Channel 1. Set the input level using the slider control or by entering a number in the window and pressing the **Enter** key on your PC..
- **Input Ch 3** – assign Input Channel 3 to the desired output bus or tie to Channel 4. Set the input level using the slider control or by entering a number in the window and pressing the **Enter** key on your PC..
- **Input Ch 4** – assign Input Channel 4 to the desired output bus or tie to Channel 3. Set the input level using the slider control or by entering a number in the window and pressing the **Enter** key on your PC..

Selecting the **Tie** button in Input Ch 1 or Input Ch 2 will tie the two controls together. Selecting the **Tie** button in Input Ch 3 or Input Ch 4 will tie the controls for these channels together.

Select the **Default** button to return to the default value.

Select the **Invert** button to invert the phase of the audio content.

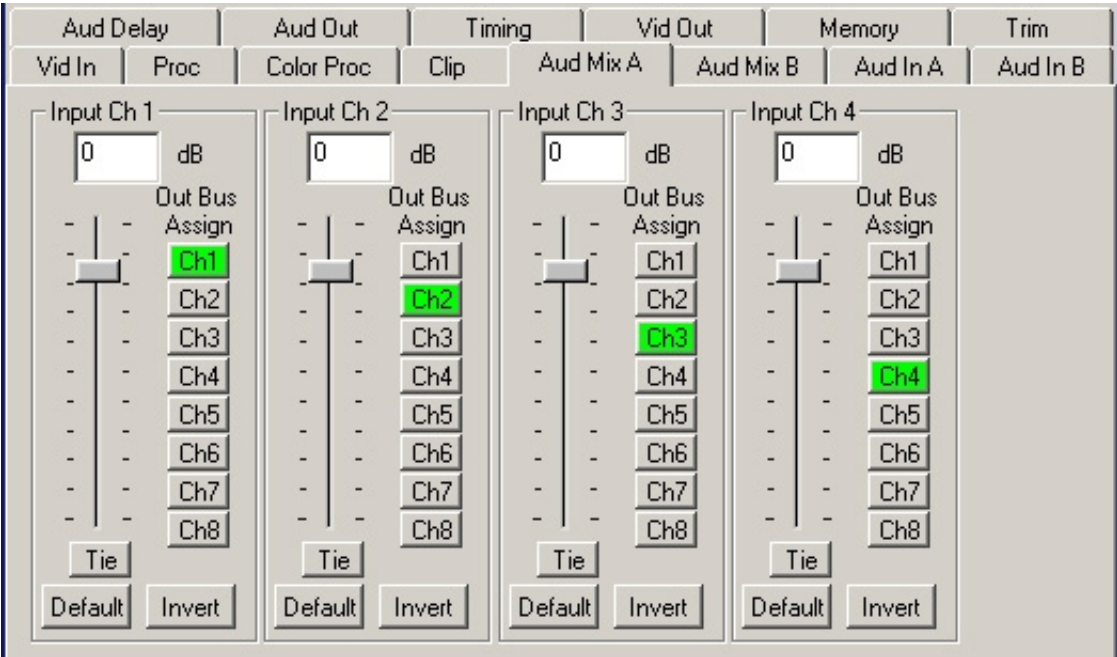

For Channels 5 –8, use the **Audio Mix B** menu shown below to set the following

- **Input Ch 5** – assign Input Channel 5 to the desired output bus or tie to Channel 6. Set the input level using the slider control or by entering a number in the window and pressing the **Enter** key on your PC.
- **Input Ch 6** – assign Input Channel 6 to the desired output bus or tie to Channel 5. Set the input level using the slider control or by entering a number in the window and pressing the **Enter** key on your PC..
- **Input Ch 7** – assign Input Channel 7 to the desired output bus or tie to Channel 8. Set the input level using the slider control or by entering a number in the window and pressing the **Enter** key on your PC..
- **Input Ch 8** – assign Input Channel 8 to the desired output bus or tie to Channel 7. Set the input level using the slider control or by entering a number in the window and pressing the **Enter** key on your PC..

Selecting the **Tie** button in Input Ch 5 or Input Ch 6 will tie the two controls together. Selecting the **Tie** button in Input Ch 7 or Input Ch 8 will tie the controls for these channels together.

Select the **Default** button to return to the default value.

Select the **Invert** button to invert the phase of the audio content.

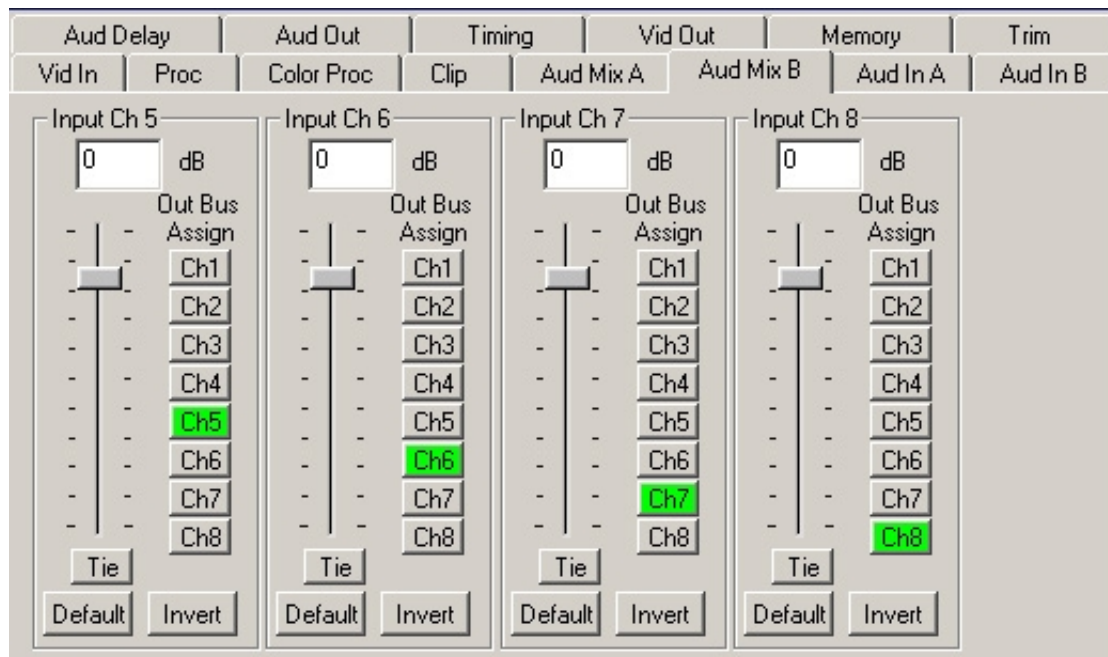

Use the **Aud In A** menu shown below for the 8415 to adjust the following parameters:

- **1/2 Input** – select the input audio source for Input 1/2.
- **3/4 Input** – select the input audio source for Input 3/4.

When an AES input pair is selected as an input, the corresponding AES BNC on the rear of the module will become an input. If an AES input is not selected, the corresponding BNC on the rear of the module will automatically become an output. Refer to the block diagram on page 4 for an illustration of the input/output BNCs.

- **1/2 Mode** – for a Serial input with embedded audio, select the type of audio in the stream:
 - **Audio** – the embedded stream is standard audio.
 - **Data** – the embedded stream is a non-audio signal.
 - **Auto** – the module will detect the type of signal embedded in the stream, audio or data.
- **3/4 Mode** – select the type of audio in the serial stream as described above.
- **DeMux Group** – select the embedded audio group to demultiplex from the selections. The status of embedded audio is shown in the **Embed In A** view. It will be reported as **None** or **Present**.

The status of the corresponding audio inputs are shown next to the control. Status is reported as one of the following:

- **No Input** – no serial digital embedded audio is detected.
- **Audio Sync** – the audio embedded in the stream is synchronous with the timing reference.
- **Data Sync** – the data embedded in the stream is synchronous with the timing reference.
- **Audio Async** – the audio embedded in the stream is non-synchronous with the timing reference.

Aud Delay		Aud Out		Timing		Vid Out		Memory		Trim	
Vid In	Proc	Color Proc	Clip	Aud Mix A	Aud Mix B	Aud In A	Aud In B				
1/2 Input			1/2 Status			1/2 Mode					
AES 1/2			No Input			Audio					
3/4 Input			3/4 Status			3/4 Mode					
AES 3/4			No Input			Audio					
DeMux Group				Embed In A							
Group 1				None							

Use the **Aud In B** menu shown below for the 8415 to adjust the following parameters:

- **5/6 Input** – select the input audio source for Input 5/6.
- **7/8 Input** – select the input audio source for Input 7/8.

When an AES input pair is selected as an input, the corresponding AES BNC on the rear of the module will become an input. If an AES input is not selected, the corresponding BNC on the rear of the module will automatically become an output. Refer to the block diagram on page 4 for an illustration of the input/output BNCs.

- **5/6 Mode** – for a Serial input with embedded audio, select the type of audio in the stream:
 - **Audio** – the embedded stream is standard audio.
 - **Data** – the embedded stream is a non-audio signal.
 - **Auto** – the module will detect the type of signal embedded in the stream, audio or data.
- **7/8 Mode** – select the type of audio in the serial stream as described above.
- **DeMux Group** – select the embedded audio group to demultiplex from the selections. The status of embedded audio is shown in the **Embed In B** view. It will be reported as **None** or **Present**.

The status of the corresponding audio inputs are shown next to the control. Status is reported as one of the following:

- **No Input** – no serial digital embedded audio is detected.
- **Audio Sync** – the audio embedded in the stream is synchronous with the timing reference.
- **Data Sync** – the data embedded in the stream is synchronous with the timing reference.
- **Audio Async** – the audio embedded in the stream is non-synchronous with the timing reference.

Aud Delay		Aud Out		Timing		Vid Out		Memory		Trim	
Vid In	Proc	Color Proc	Clip	Aud Mix A	Aud Mix B	Aud In A	Aud In B				
5/6 Input		5/6 Status		5/6 Mode							
AES 5/6		No Input		Audio							
7/8 Input		7/8 Status		7/8 Mode							
AES 7/8		No Input		Audio							
DeMux Group		Embed In B									
Group 1		None									

Use the **Aud Delay** menu shown below to adjust the amount of audio delay on the output:

- **Auto Track** – enable auto tracking by selecting **On** or **Off**.
- **Bulk Delay** – set the amount of bulk delay using the left and right arrows or enter a value in the **msec** field and press the **Enter** key on your PC..

The amount of total delay will be reported in nsec in the **Total Delay** window.



Use the **Aud Out** menu shown below to adjust the following audio output parameters:

- **Audio Embed A** – turn embedding **Off** for no embedding to take place in the output signal. Select **Replace** to replace the targeted group in the stream with new content. If there is no such group already present, the new content will be placed in the horizontal interval in normal cascade, following any other content already there. When **Cascade** is selected, the audio channels are placed after any existing content. **Replace All** will strip all of the original content and the new content is placed at the beginning of the horizontal interval.
- **Audio Embed B** – identical to **Audio Embed A** but no **Replace All** function is required as this will occur upstream in the A embedder..
- **Mux Group A** – select the multiplexed group to be embedded in embedder A in the output.
- **Mux Group B** – select the multiplexed group to be embedded in embedder B in the output.
- **Dig Ref Level** – set the digital reference level for the audio output.

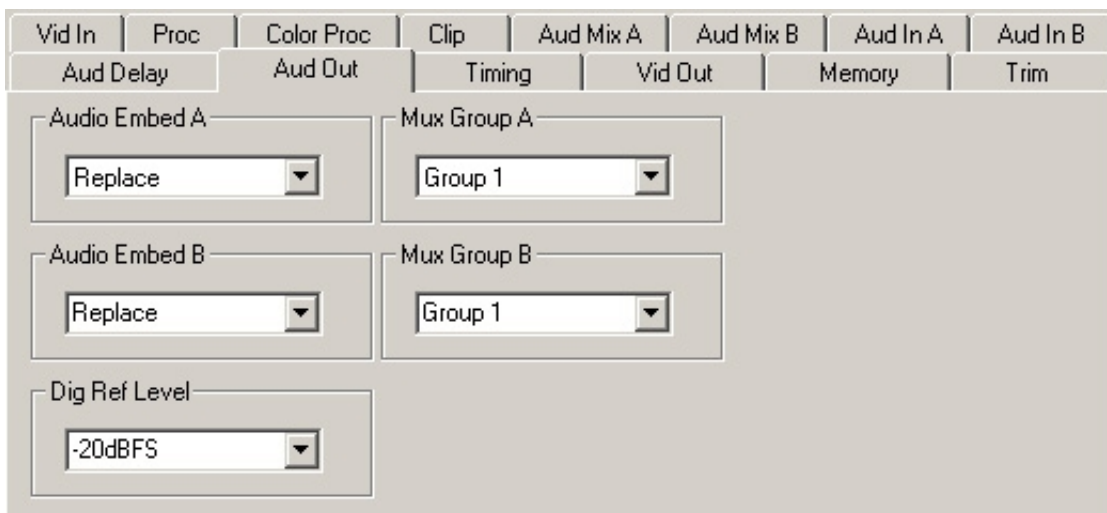

Model 7500 HD Video Frame Sync

Use the **Timing** menu shown below to adjust the following parameters:

- **Frame Sync** – turn the Frame Sync function on or off.
- **Timing** – when Frame Sync is on, adjust the horizontal timing of the output signal to place the leading edge of sync coincident with other sources.
- **Frame Delay** – for asynchronous inputs, set the amount of frame delay desired..

This menu provides a **Delay** window at the bottom of the screen that will report the total delay in lines of the module.

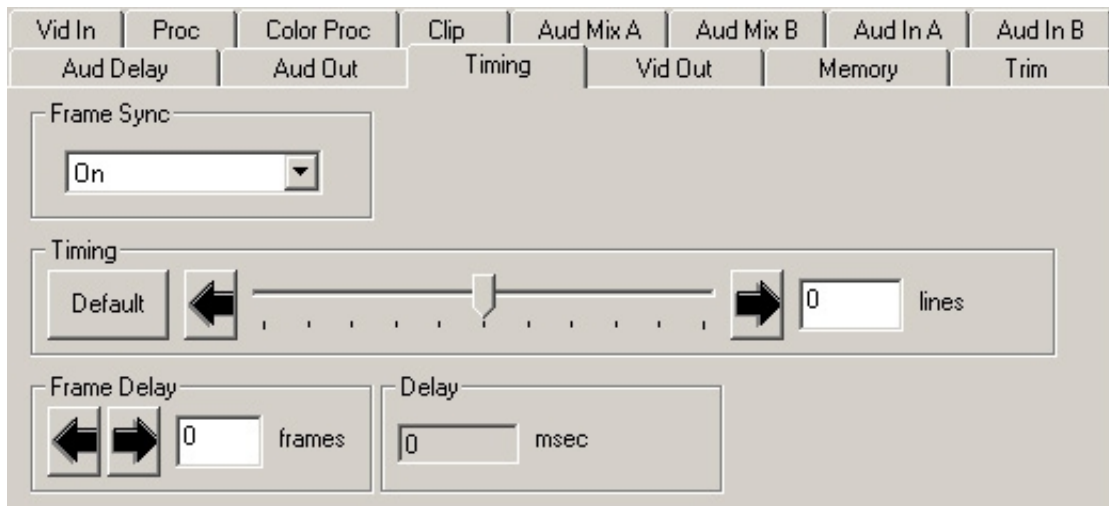

Use the **Vid Out** menu shown below to adjust the following parameters:

- **Bypass** – set to **Normal** or **Bypass** to completely bypass any digital processing.
- **Vert Blanking** – set the vertical blanking for **Wide** or **Narrow**.
- **Test Pattern** – select a test pattern to be sent to the video output of the module.
- **Signal Mute** – set to either mute the output to black when noise is present, to freeze to the last frame, or select no muting.
- **Strip Audio** – select the box to strip embedded audio from the output. Leave the box unselected to pass embedded audio through to the output.

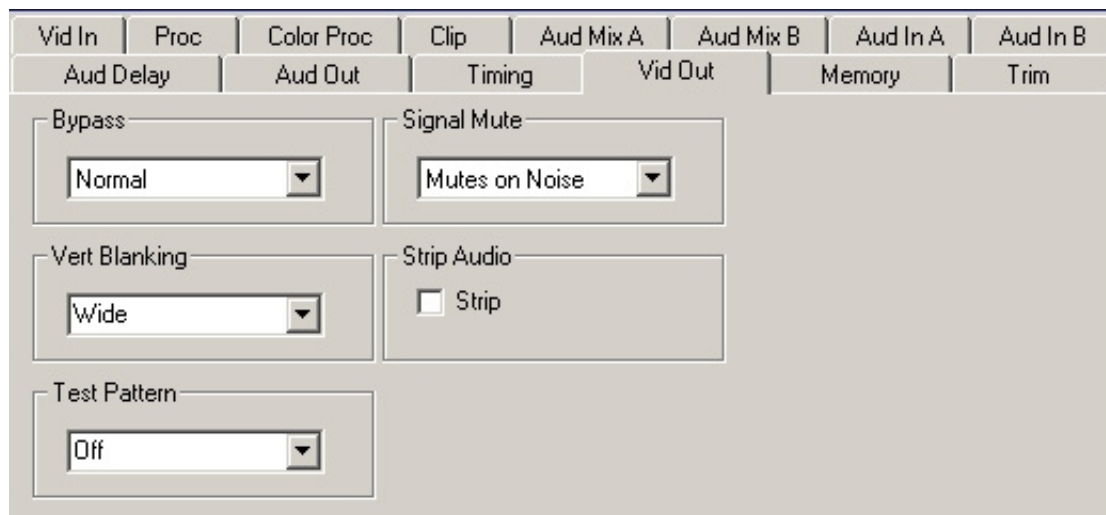

The **Memory** menu shown below allows you to save overall module setups to five memory registers as follows:

- Select **Save**, then one of the five memory registers **Reg 1 – 5**. The box will turn green. The entire module setup is now saved in the selected register.
- To recall a register, select the register box. If there is information saved, the box will turn green. The saved setup will now be loaded to the module. Up to five different module setups can be saved and recalled using the individual registers.

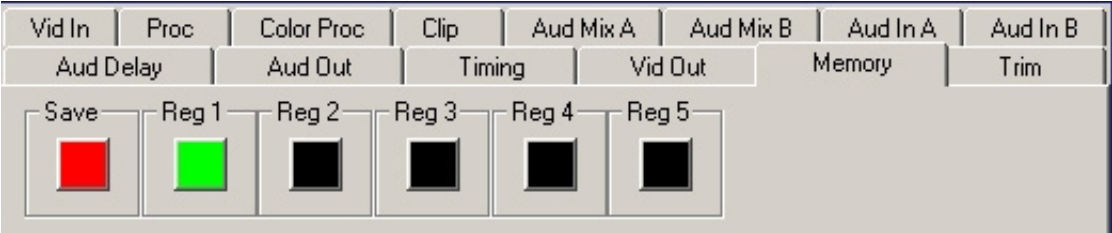

The **Trim** menu allows you to correct subtle issues in the individual color difference channels with offset and gain controls. The offset controls adjust the DC offsets above or below the nominal points. This can be used to correct black balance errors. The gain controls adjust the amplitude of each channel.

Use the controls described below to make the offset and gain corrections:

- **Cb Offset** – adjust the DC offset of the Cb channel to between ± 100 IRE.
- **Cr Offset** – adjust the DC offset of the Cr channel to between ± 100 IRE.
- **Cb Gain** – adjust the amplitude of the Cb channel to between ± 20 IRE.
- **Cr Gain** – adjust the amplitude of the Cr channel to between ± 20 IRE.

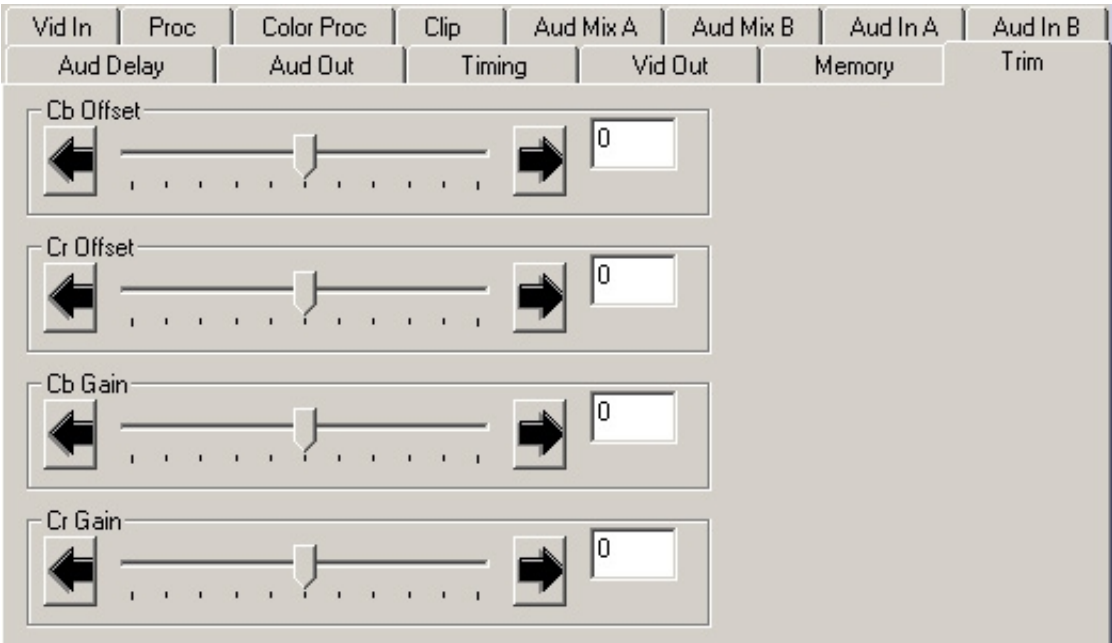

Avenue Touch Screen Remote Configuration

The Avenue Touch Screen remote control status menu for this module is illustrated and explained below. Refer to the **7500 Parameter Table** for a summary of available parameters that can be set remotely through the menus illustrated. The **Configuration Summary** gives tips and general background information on setting the parameters. For more information on using Avenue Touch Screen, refer to the Avenue System Overview.

Parameter fields that are grayed out can indicate one of the following conditions:

- An option is not installed.
- The function is not active.
- The module is locked.
- The User Level set with Avenue PC is not accessible from the current User Level.

7500 Avenue Touch Screen Menus

The **Vid In** menu shown below allows you to configure the following input sources:

- **Ref Source** – use this control to set the reference input source.

Status reporting is provided for the following conditions:

- **Input** – reports the input status as **No Input**, **720p/50**, **720p/59.94**, **1080i/50**, **1080i/59.94**, **1080p/25**, **1080p/23.98**, **1080sF/25**, **1080sF/23.98**, or **Unknown Std.**
- **Input Error** – reports one of the following errors: **No Error**, **No Input Lock**, **EDH/CRC Error**, and **TRS Error**.
- **Error Seconds** – displays the number of seconds that a detected EDH error has been present in the serial data stream.
- **Reference** – reports the status of the reference input as either **No Reference**, **Ref Mismatch**, **Ref Unlocked**, **Ref 525 Lock**, **Ref 625 Lock**, or **TLS Lock**.

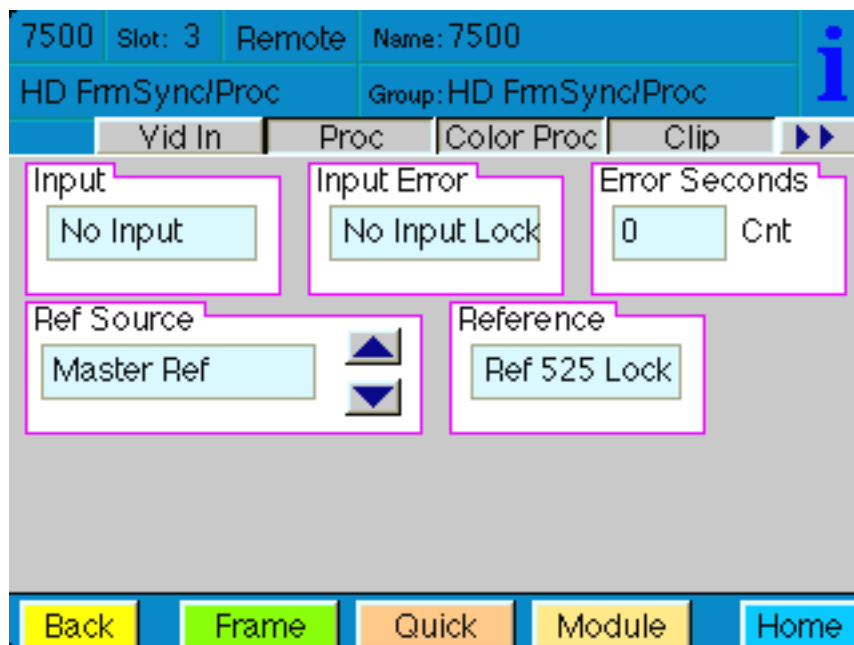

The **Proc** menu shown below allows you to adjust the following video processing parameters for the signal:

- **Gain** – adjust the percentage of overall gain (luminance and chrominance).
- **Chroma** – adjust the percentage of chroma amplitude.
- **Pedestal** – adjust the pedestal (black) level of the signal in IRE.
- **Hue** – adjust the hue of the signal ± 180 degrees.

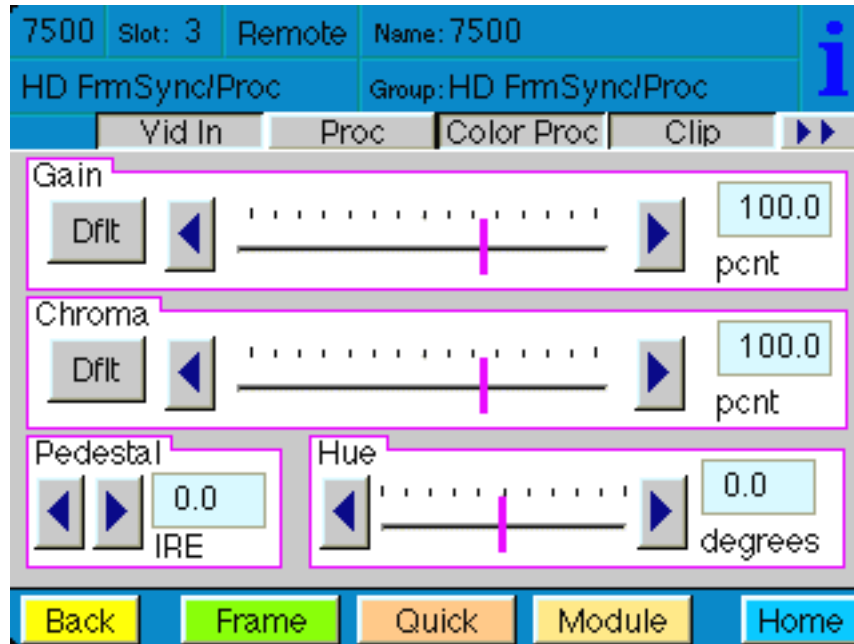

The **Color Proc** menu shown below allows you to select a target hue and adjust color correction parameters for the selected target color without disturbing other colors in the scene.

Note: If not using this menu for color processing, make sure all color proc parameters are set for default values.

- **Target Hue** – use to select a particular hue to change with the Color proc controls.
- **Selectivity** – use this control to adjust range of the target hue selected.

Tip: To help identify where to set the Target Hue and Selectivity, temporarily turn down the Luminance or Chroma control below. Rotate the Target Hue and adjust the Sensitivity until you can determine the exact color area you wish to change. Return the Luminance or Chroma control to 100% once the Target Hue and Selectivity controls are set for the correct color.

- **Luminance** – once the Target Hue has been identified, adjust the percentage of overall lightness and darkness for the targeted hue.
- **Pedestal** – adjust the pedestal (black) level of the signal if necessary in IRE.
- **Chroma** – once the Target Hue has been identified, adjust the percentage of overall color saturation for the targeted hue.
- **Hue** – adjust the hue of the signal ± 180 degrees.

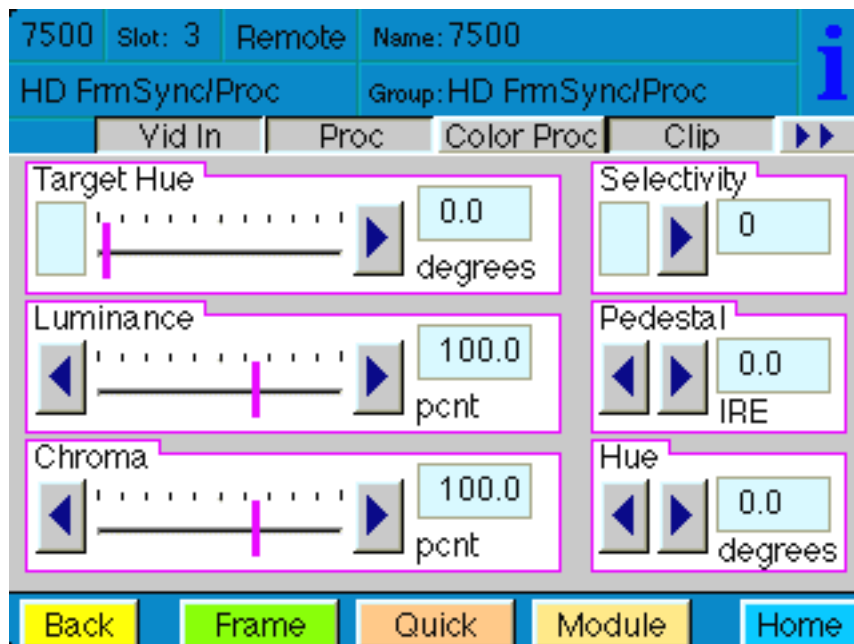

Use the **Clip** menu shown below to enable or disable the **Legalizer** circuitry on the module which allows adjustment the following parameters:

- **Off** – for no Legalizer.
- **Y-Cr-Cb** – selecting this choice will enable the **Black** and **White Clip**, and **Chroma Limiting** controls at the right of the menu.
 - **Black Clip** – set the threshold for the black clip level. (No content will be allowed below the level set.)
 - **White Clip** – set the threshold for the white clip. (No content will be allowed above the level set.)
 - **Chroma Limit** – adjust the percentage of chroma limiting desired for the output.
- **Legal RGB** –selecting this choice will set the module to default legal RGB parameters set on a pixel by pixel basis and will gray out the clip and chroma limit controls.

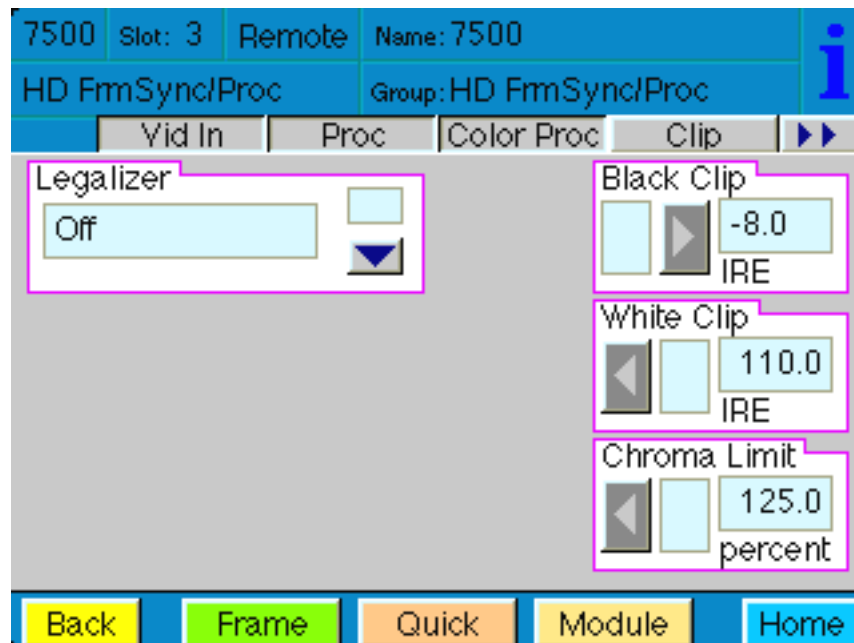

When an 8415 Audio Processor submodule is installed, use the **Aud Mix A** and **B** menus shown to control the audio input levels and mixing and shuffling of the audio inputs to output. Each output bus assignment will be indicated by a green box.

For Channels 1 –4, use the **Audio Mix A** menu to set the following

- **Input Ch 1** – assign Input Channel 1 to the desired output bus or tie to Channel 2. Set the input level using the slider control or by entering a number in the window and pressing the **Enter** key on your PC.
- **Input Ch 2** – assign Input Channel 2 to the desired output bus or tie to Channel 1. Set the input level using the slider control or by entering a number in the window and pressing the **Enter** key on your PC..
- **Input Ch 3** – assign Input Channel 3 to the desired output bus or tie to Channel 4. Set the input level using the slider control or by entering a number in the window and pressing the **Enter** key on your PC..
- **Input Ch 4** – assign Input Channel 4 to the desired output bus or tie to Channel 3. Set the input level using the slider control or by entering a number in the window and pressing the **Enter** key on your PC..

Selecting the **Tie** button in Input Ch 1 or Input Ch 2 will tie the two controls together. Selecting the **Tie** button in Input Ch 3 or Input Ch 4 will tie the controls for these channels together.

Select the **Default** button to return to the default value.

Select the **Invert** button to invert the phase of the audio content. reference.

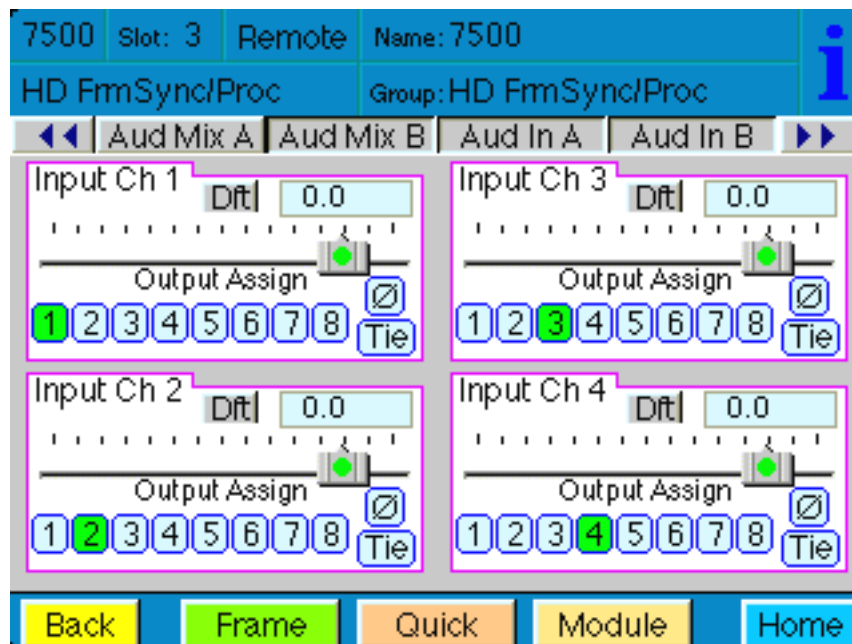

For Channels 5 –8, use the **Audio Mix B** menu shown below to set the following

- **Input Ch 5** – assign Input Channel 5 to the desired output bus or tie to Channel 6. Set the input level using the slider control or by entering a number in the window and pressing the **Enter** key on your PC.
- **Input Ch 6** – assign Input Channel 6 to the desired output bus or tie to Channel 5. Set the input level using the slider control or by entering a number in the window and pressing the **Enter** key on your PC..
- **Input Ch 7** – assign Input Channel 7 to the desired output bus or tie to Channel 8. Set the input level using the slider control or by entering a number in the window and pressing the **Enter** key on your PC..
- **Input Ch 8** – assign Input Channel 8 to the desired output bus or tie to Channel 7. Set the input level using the slider control or by entering a number in the window and pressing the **Enter** key on your PC..

Selecting the **Tie** button in Input Ch 5 or Input Ch 6 will tie the two controls together. Selecting the **Tie** button in Input Ch 7 or Input Ch 8 will tie the controls for these channels together.

Select the **Default** button to return to the default value.

Select the **Ø** button to invert the phase of the audio content.

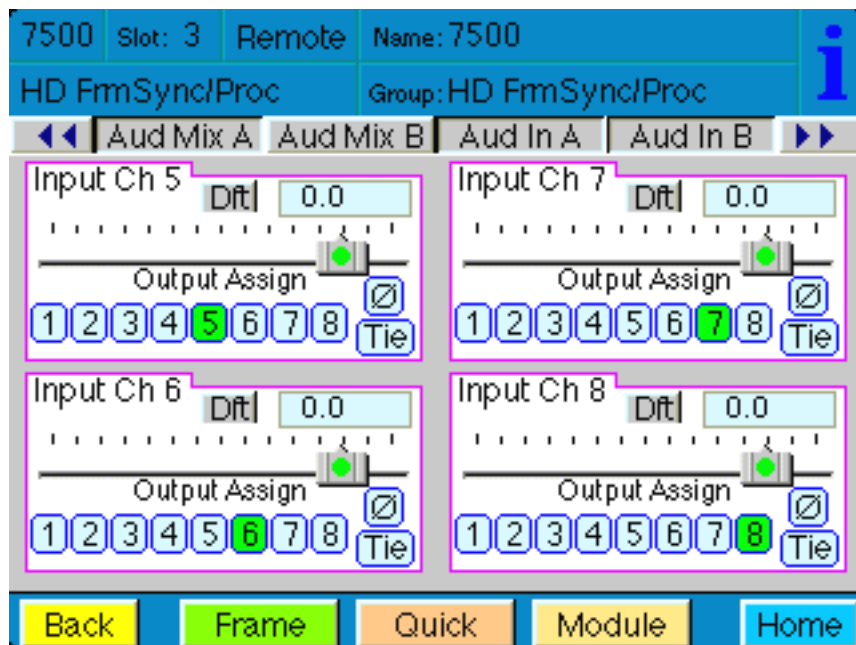

Use the **Aud In A** menu shown below for the 8415 to adjust the following parameters:

- **1/2 Input** – select the input audio source for Input 1/2.
- **3/4 Input** – select the input audio source for Input 3/4.

When an AES input pair is selected as an input, the corresponding AES BNC on the rear of the module will become an input. If an AES input is not selected, the corresponding BNC on the rear of the module will automatically become an output. Refer to the block diagram on page 4 for an illustration of the input/output BNCs.

- **1/2 Mode** – for a Serial input with embedded audio, select the type of audio in the stream:
 - **Audio** – the embedded stream is standard audio.
 - **Data** – the embedded stream is a non-audio signal.
 - **Auto** – the module will detect the type of signal embedded in the stream, audio or data.
- **3/4 Mode** – select the type of audio in the serial stream as described above.
- **DeMux Group** – select the embedded audio group to demultiplex from the selections. The status of embedded audio is shown in the **Embed In A** view. It will be reported as **None** or **Present**.

The status of the corresponding audio inputs are shown next to the control. Status is reported as one of the following:

- **No Input** – no serial digital embedded audio is detected.
- **Audio Sync** – the audio embedded in the stream is synchronous with the timing reference.
- **Data Sync** – the data embedded in the stream is synchronous with the timing reference.
- **Audio Async** – the audio embedded in the stream is non-synchronous with the timing reference.

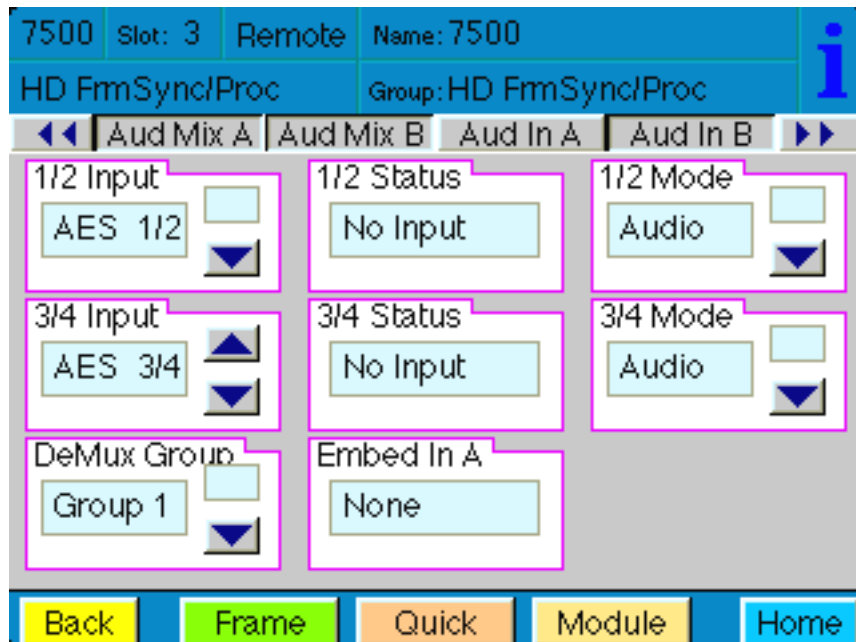

Use the **Aud In B** menu shown below for the 8415 to adjust the following parameters:

- **5/6 Input** – select the input audio source for Input 5/6.
- **7/8 Input** – select the input audio source for Input 7/8.

When an AES input pair is selected as an input, the corresponding AES BNC on the rear of the module will become an input. If an AES input is not selected, the corresponding BNC on the rear of the module will automatically become an output. Refer to the block diagram on page 4 for an illustration of the input/output BNCs.

- **5/6 Mode** – for a Serial input with embedded audio, select the type of audio in the stream:
 - **Audio** – the embedded stream is standard audio.
 - **Data** – the embedded stream is a non-audio signal.
 - **Auto** – the module will detect the type of signal embedded in the stream, audio or data.
- **7/8 Mode** – select the type of audio in the serial stream as described above.
- **DeMux Group** – select the embedded audio group to demultiplex from the selections. The status of embedded audio is shown in the **Embed In B** view. It will be reported as **None** or **Present**.

The status of the corresponding audio inputs are shown next to the control. Status is reported as one of the following:

- **No Input** – no serial digital embedded audio is detected.
- **Audio Sync** – the audio embedded in the stream is synchronous with the timing reference.
- **Data Sync** – the data embedded in the stream is synchronous with the timing reference.
- **Audio Async** – the audio embedded in the stream is non-synchronous with the timing reference.

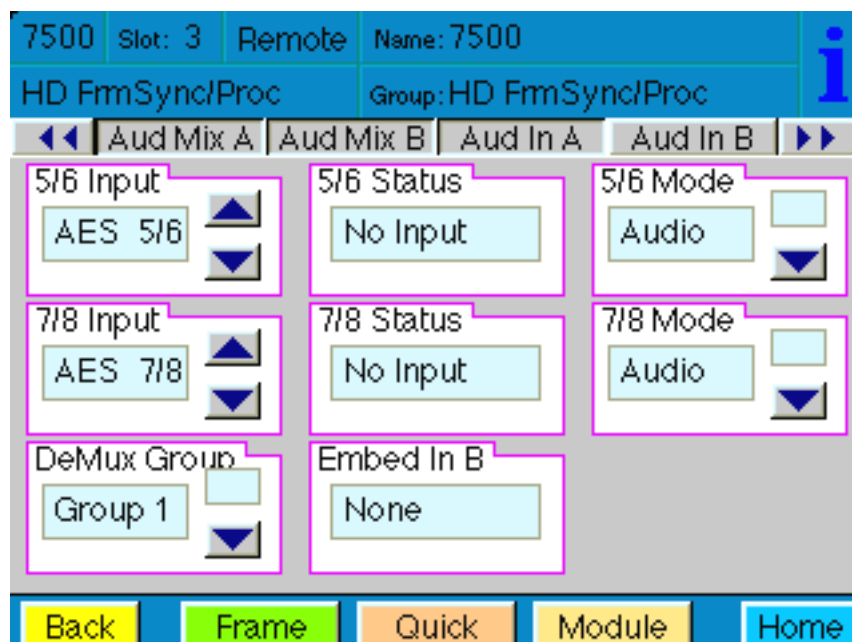

Model 7500 HD Video Frame Sync

Use the **Aud Delay** menu shown below to adjust the amount of audio delay on the output:

- **Auto Track** – enable auto tracking by selecting **On** or **Off**.
- **Bulk Delay** – set the amount of bulk delay using the left and right arrows or enter a value in the **msec** field and press the **Enter** key on your PC..

The amount of total delay will be reported in nsec in the **Total Delay** window.

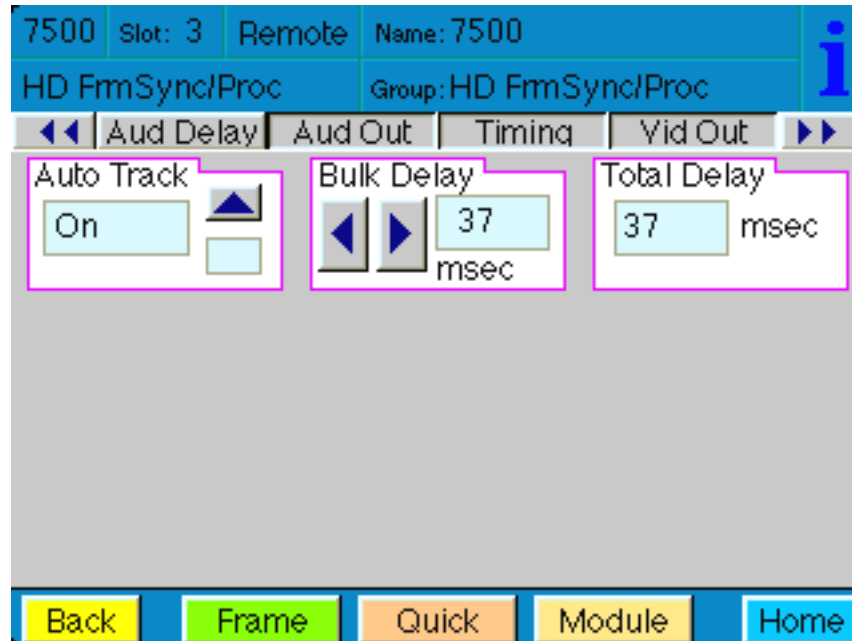

Use the **Aud Out** menu shown below to adjust the following audio output parameters:

- **Audio Embed A** – turn embedding **Off** for no embedding to take place in the output signal. Select **Replace** to replace the targeted group in the stream with new content. If there is no such group already present, the new content will be placed in the horizontal interval in normal cascade, following any other content already there. When **Cascade** is selected, the audio channels are placed after any existing content. **Replace All** will strip all of the original content and the new content is placed at the beginning of the horizontal interval.
- **Audio Embed B** – identical to **Audio Embed A** but no **Replace All** function is required as this will occur upstream in the A embedder..
- **Mux Group A** – select the multiplexed group to be embedded in embedder A in the output.
- **Mux Group B** – select the multiplexed group to be embedded in embedder B in the output.
- **Dig Ref Level** – set the digital reference level for the audio output.

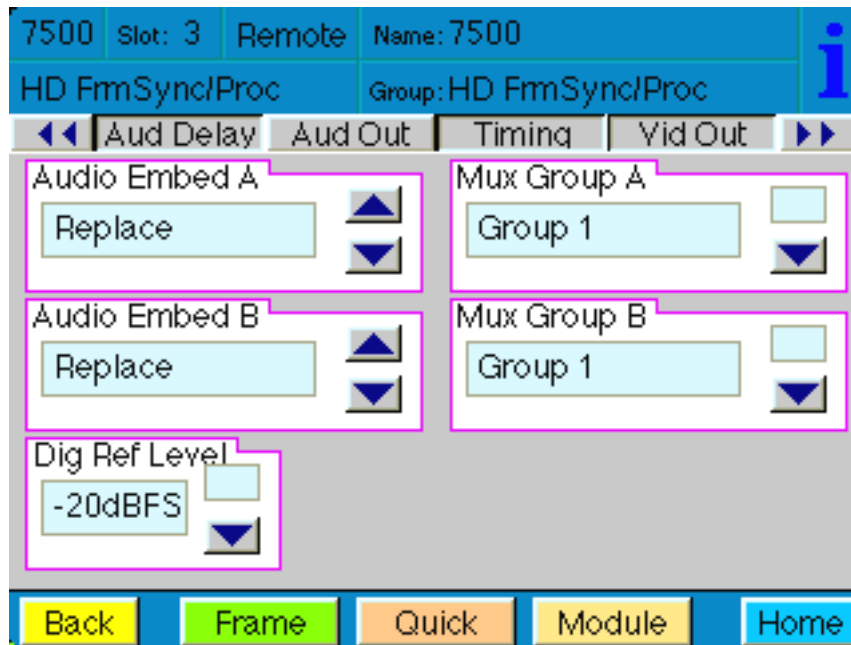

Model 7500 HD Video Frame Sync

Use the **Timing** menu shown below to adjust the following parameters:

- **Frame Sync** – turn the Frame Sync function on or off.
- **Timing** – when Frame Sync is on, adjust the horizontal timing of the output signal to place the leading edge of sync coincident with other sources.
- **Frame Delay** – for asynchronous inputs, set the amount of frame delay desired..

This menu provides a **Delay** window at the bottom of the screen that will report the total delay in lines of the module.

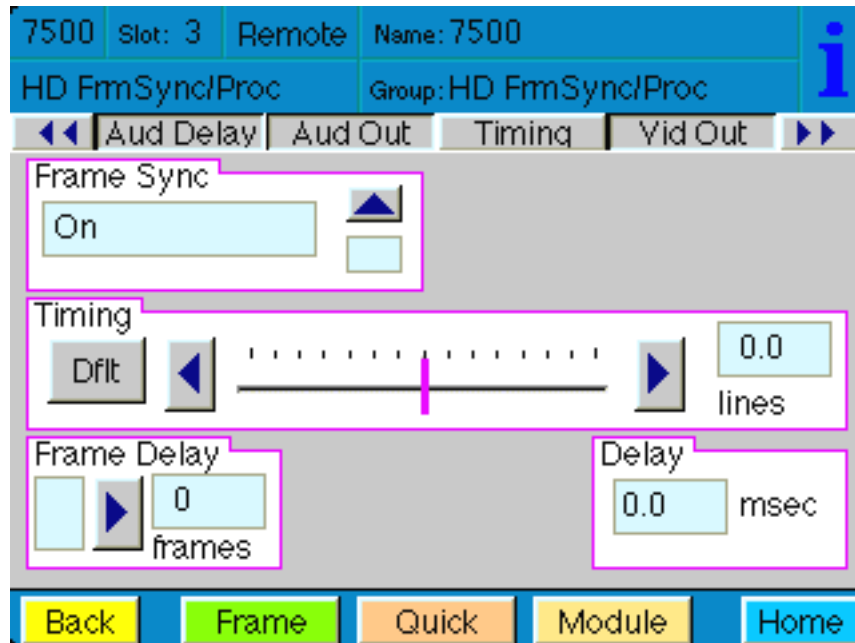

Use the **Vid Out** menu shown below to adjust the following parameters:

- **Bypass** – set to **Normal** or **Bypass** to completely bypass any digital processing.
- **Vert Blanking** – set the vertical blanking for **Wide** or **Narrow**.
- **Test Pattern** – select a test pattern to be sent to the video output of the module.
- **Signal Mute** – set to either mute the output to black when noise is present, to freeze to the last frame, or select no muting.
- **Strip Audio** – select the box to strip embedded audio from the output. Leave the box unselected to pass embedded audio through to the output.

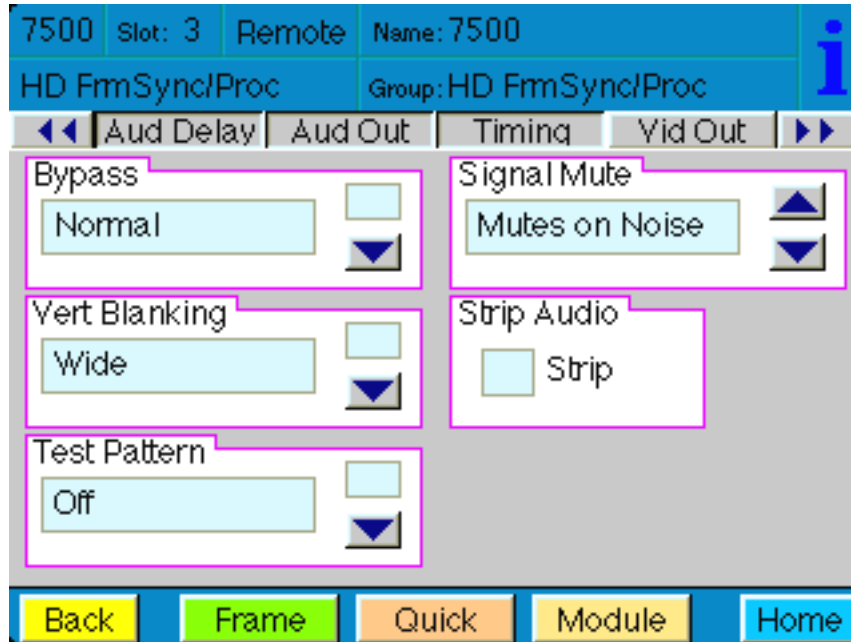

Model 7500 HD Video Frame Sync

The **Memory** menu shown below allows you to save overall module setups into up to five memory registers as follows:

- Select **Save**, then one of the five memory registers **Reg 1 – 5**. The box will turn green. The entire module setup is now saved in the selected register.
- To recall a register, select the register box. If there is information saved, the box will turn green. The saved setup will now be loaded to the module. Up to five different module setups can be saved and recalled using the individual registers.

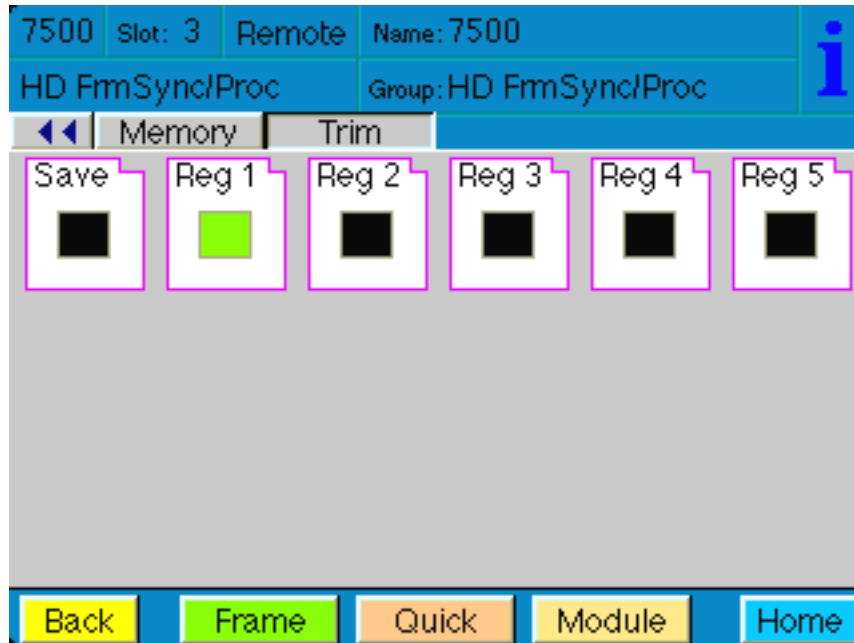

The **Trim** menu allows you to correct subtle issues in the individual color difference channels with offset and gain controls. The offset controls adjust the DC offsets above or below the nominal points. This can be used to correct black balance errors. The gain controls adjust the amplitude of each channel.

Use the controls described below to make the offset and gain corrections:

- **Cb Offset** – adjust the DC offset of the Cb channel to between ± 100 IRE.
- **Cr Offset** – adjust the DC offset of the Cr channel to between ± 100 IRE.
- **Cb Gain** – adjust the amplitude of the Cb channel to between ± 20 IRE.
- **Cr Gain** – adjust the amplitude of the Cr channel to between ± 20 IRE.

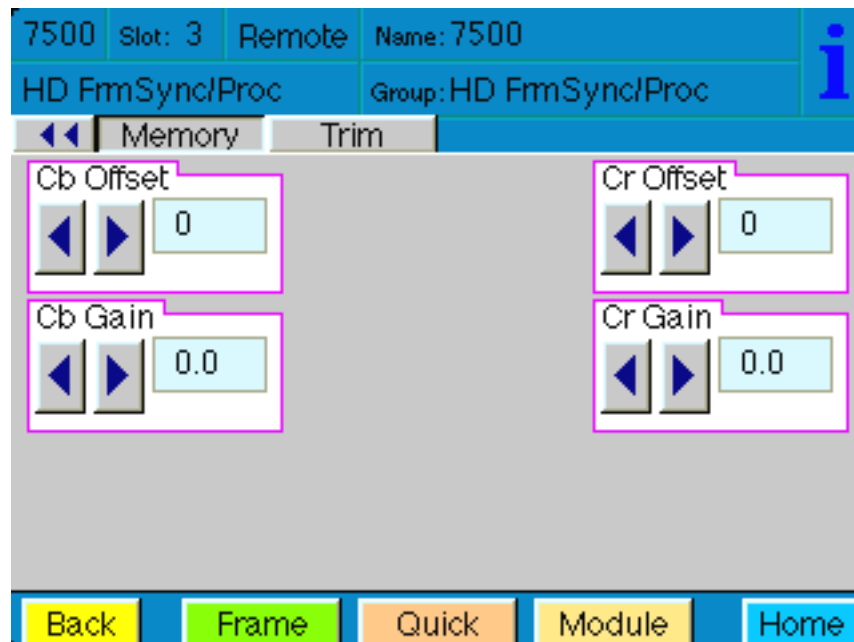

TROUBLESHOOTING

As a troubleshooting aid, the reference signal status and presence, power and CPU status can be easily monitored from the front panel of this module using the front panel indicators.

Refer to the overall troubleshooting tips given below for the module:

Can't control module:

- Check status of CPU **Run** green LED. Should be blinking slowly and in unison with other modules if System module is present. If not, try removing it and plugging it in again to be sure it is seated properly.
- System module may not be working properly if installed.

Module controls are grayed out:

- Module is locked or access to module controls is restricted by User Level.
- Local/Remote switch on module is in the **Local** position.

No signals out of module:

- Check status of **Active** LEDs. Primary or Secondary should be lit. If not, check all inputs for presence and quality.
- Check cabling to inputs of module.
- Check inputs to destinations are terminated properly.

One hue or color is incorrect:

- If not using Color Proc menu, be sure Color Processing parameters in that menu are set to defaults.

You may also refer to the technical support section of the Ensemble Designs web site for the latest information on your equipment at the URL below:

<http://www.ensembledesigns.com/support>

SOFTWARE UPDATING

Software upgrades for each module can be downloaded remotely if the optional System Control module is installed. These can be downloaded onto your PC and then Avenue PC will distribute the update to the individual module. (Refer to the Avenue PC documentation for more information). Periodically updates will be posted on our web site. If you do not have the required System Control Module and Avenue PC, modules can be sent back to the factory for software upgrades.

WARRANTY AND FACTORY SERVICE

Warranty

This module is covered by a five year limited warranty, as stated in the main Preface of this manual. If you require service (under warranty or not), please contact Ensemble Designs and ask for customer service before you return the unit. This will allow the service technician to provide any other suggestions for identifying the problem and recommend possible solutions.

Factory Service

If you return equipment for repair, please get a Return Material Authorization Number (RMA) from the factory first.

Ship the product and a written description of the problem to:

Ensemble Designs, Inc.

Attention: Customer Service RMA #####

870 Gold Flat Rd.

Nevada City, CA. 95959 USA

(530) 478-1830

Fax: (530) 478-1832

service@ensembledesigns.com

<http://www.ensembledesigns.com>

Be sure to put your RMA number on the outside of the box.

SPECIFICATIONS

7500 HD Video Processor Frame Sync

Input

Number	One
Signal Type	HD Serial Digital video, SMPTE 274M & 296M
Impedance	75 Ω
Return Loss	> 15 dB DC to 1.5 GHz
Standards Supported	1080i (SMPTE 274M-4,5,6) 50, 59.94 or 60 Hz 720p (SMPTE 296M-1,2,3) 59.94 or 60 Hz 1080p (SMPTE 274M-9,10,11) 23.98, 24, 25 Hz 1080sf (RP211-14,15,16) 23.98, 24, 25 Hz

Output

Number	Four
Type	HD Serial Digital video, SMPTE 274M & 296M
Impedance	75 Ω
Return Loss	> 15 dB DC to 1.5 GHz

Reference Input

Number	One external (module's BNC) One internal (Frame Master Ref BNC)
Type	PAL or NTSC composite video or HD Tri-level Sync
Return Loss	> 40 dB (applies to external ref input)

General

Power Consumption	10 watts (with option installed)
Temperature	0 to 40° C ambient (all specifications met)
Relative Humidity	0 to 95%, noncondensing
Size	Standard Avenue Module Occupies one slot in 3RU or 1RU Frame (including 8415 Audio Processor)

8415 Audio Processor

AES/EBU Digital Inputs

Number	4 (Total of eight channels)
Type	AES3id
Connectorization	Coaxial, 75 Ω BNC
Bit Depth	20 or 24 Bit
Sample Rate	30KHz to 100KHz (Sample Rate Converted internally to 48KHz)
Reference Level	-18 or -20 dBFS (Selectable)
AC-3, Dolby-E	Supported when inputs are synchronous

Embedded Inputs

Number	4 (from SDI video input) 8 channels from any 2 of 4 groups Selectable to any of 4 groups
Type	SMPTE 274M Compliant Selectable to any of four groups
Channels	Four
Bit Depth	20 or 24 Bit

AES/EBU Digital Outputs

Number	4 (Total of eight channels)
Type	AES3id
Connectorization	Coaxial, 75 Ω BNC
Bit Depth	20 or 24 Bit
Sample Rate	48 KHz Synchronous to Video output
Reference Level	-18 or -20 dBFS (Selectable)

Embedded Output

Number	4 or 2, depending on configuration
Type	SMPTE 274M Compliant
Group Assign	Cascade, or Replace any of 2 of four groups
Bit Depth	20 or 24 Bit

