

**AVENUE**

Avenue™ signal integration system

# Model 7450 HD Protection Switch Data Pack

**ENSEMBLE**

D E S I G N S

Revision 1.2 SW v2.2.5

## Contents

MODULE OVERVIEW	4
SDI Signal Evaluation	4
APPLICATIONS	7
Auto-Switched Upconversion Application	7
Fiber Feed Application	7
3RU and 1RU Backplane Diagrams	8
Status and Alarm Cabling	9
MODULE CONFIGURATION AND CONTROL	10
7450 Parameter Table	11
Front Panel Controls and Indicators	13
AVENUE PC REMOTE CONFIGURATION	14
7450 Avenue PC Menus	14
Status Menu	14
Config Menu	16
Blk Detect Menu	17
Aud Detect Menu	18
Freeze Menu	19
Pri Errors Menu	20
Sec Errors Menu	21
GPI Menu	22
Inputs Menu	23
Memory Menu	24
AVENUE TOUCH SCREEN REMOTE CONFIGURATION	25
7450 Avenue Touch Screen Menus	25
Status Menu	25

Config Menu	27
Blk Detect Menu	28
Aud Detect Menu	29
Freeze Menu	30
Pri Errors Menu	31
Sec Errors Menu	32
GPI Menu	33
Inputs Menu	34
Memory Menu	35
TROUBLESHOOTING	36
SOFTWARE UPDATES	36
WARRANTY AND FACTORY SERVICE	37
Warranty	37
Factory Service	37
SPECIFICATIONS	38

## MODULE OVERVIEW

The 7450 module is a fail-safe, bypass protection switch for critical digital paths for broadcast or satellite applications. When a fault is detected in the primary input, and the secondary input is verified as good, the switch will activate, causing the secondary input to be switched to the module's output. The 7450 includes a passive, fail-safe path that ensures there is an output even in the event of a total power failure.

The 7450 supports HD SDI signals. Different types of signal testing (vetting) can be enabled on the 7450 and it will apply the tests automatically and independently for the Primary and Secondary inputs.

The health of a high definition video signal is determined by monitoring crucial parameters in order of increasing complexity; Timing Reference Signal (TRS), or a persistent loss of digital sync is tested first. Black, Embedded Audio and Freeze are also evaluated. Each test can be configured by the user. For example, the sophisticated Black Detector includes configurable parameters for black level threshold, pixel count, and duration time.

The switch can operate in two modes: automatic or non-resetting. In fully automatic mode, the 7450 will automatically switch back to the primary signal once it's been restored. In the non-resetting mode, the secondary input remains routed to the output, even after the primary input has recovered.

Controls are easily accessed through an Avenue Control Panel, Avenue PC software, GPIs, or front edge module controls. GPI inputs allow faults detected in upstream equipment to contribute to the switching logic.

### SDI Signal Evaluation

The 7450 monitors the integrity of the serial digital input stream and analyzes its audio and video content. HD SDI signal health and fault detection is determined by monitoring any or all of the following parameters, in order of increasing complexity:

- **Timing Reference Signal (TRS)** – This parameter checks for the persistent loss of digital sync by looking for the correct Timing Reference Signal carried in the serial video stream. When this digital sync format is correct, the signal is considered good.
- **Black** – Black detection is based on three configurable parameters: black level threshold, black pixel count, and black duration time. All of these parameters can be set using the menu system to meet the needs of specific video signal inputs.
- **Embedded Audio** – This parameter will look for correctly configured embedded audio packets in the horizontal intervals of the signals. The actual audio content of the packets is further analyzed to detect silence. Specific audio parameters, such as audio group, silence threshold level, and audio silence duration can be configured in the Avenue PC and Touch Screen menus.
- **Freeze** – This parameter checks for a freeze condition as determined by the settings selected in the Freeze menu.

A sophisticated black detection system is employed to activate the switch in the event that the signal is lost. It allows the user to select not only the threshold and percentage of non-black pixels, but also the portion of the picture to be considered. The area of the picture checked is determined by selecting

**Small Window** which is approximately two thirds of the picture width and height, or **Big Window** which covers approximately 90% of the width and height. This allows a corner Bug to be either excluded or included in the detection process.

Black detection is performed on a pixel-by-pixel basis within the selected window, with user selectable **Detect Level** and **Blk Frac** adjustments. Pixels above the **Detect Level** are considered as being non-black. **Blk Frac** sets the percentage of pixels which must be non-black. If **Detect Level** is set to 12 IRE and **Blk Frac** is set to 10% then the 7450 expects there to be pixel levels above 12 IRE for more than 10% of each frame. For example, if **Blk Time** is set to 3 seconds, if less than 10% of the pixels in each frame are above the selected 12 IRE level for a period of 3 seconds, a switch will occur.

**Pri Valid** and **Sec Valid** are dynamic values based on incoming video. In the above example, if **Pri Valid** fell below **Blk Frac** continuously for 3 seconds there would be a switch, provided that there is valid secondary video. Note however, that the display may not keep pace with short duration transitions of actual video. In the example, an excursion above 12 IRE for a single frame every 2 seconds would not cause a switch to take place, since the 3 second count would be reinitialized by these valid frames.

The block diagram below illustrates the signal flow of the 7450. Note that in the event of power failure, the passive relay passes the primary input to the Relay Protected Output.

The Primary and Secondary inputs pass through serial digital receiver/equalizers for buffering. When a fault is detected in the Primary input, and the Secondary input is seen as not faulted, the electronic

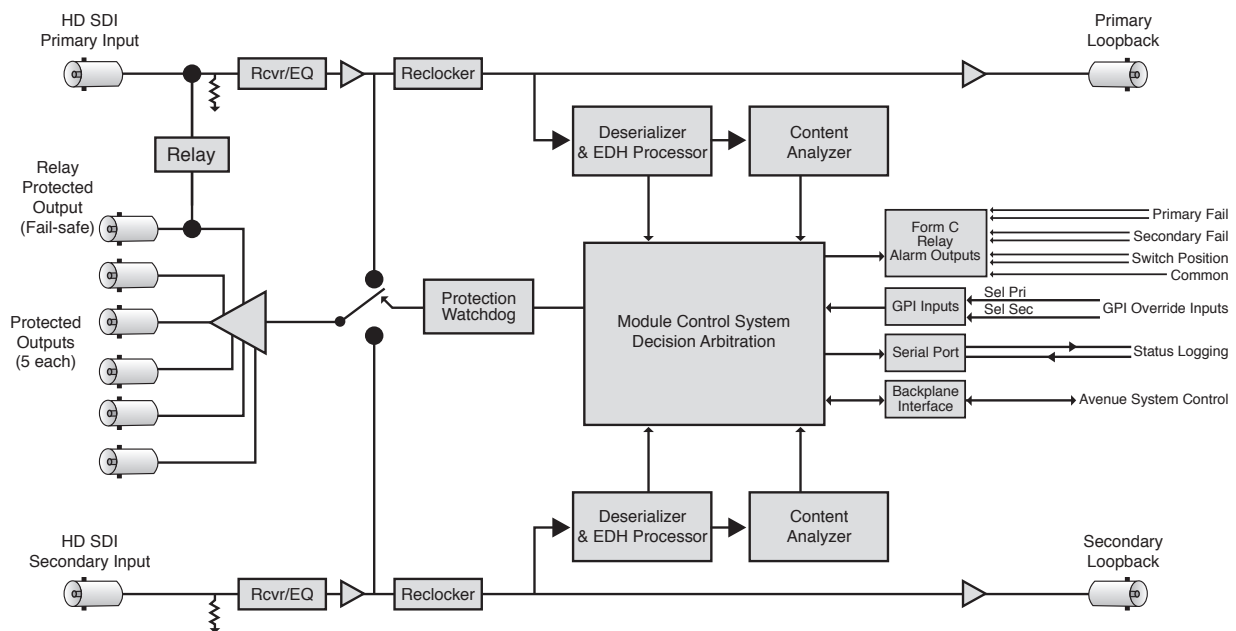

7450 HD Protection Switch

Each of the signals is fed to identical detection circuits which evaluate multiple parameters and characteristics of the signal in order to arrive at a fault decision. Detection of TRS errors is done in a Receiver/Reclocker circuit which produces a reclocked serial output feeding a Deserializer circuit. The output of this section then feeds a Field Programmable Gate Array (FPGA) where the signals are vetted, or tested for configured parameters. The Signal Vetter™ process in the FPGA detects the parameters chosen by the user using either the front panel controls or through the Avenue PC or Touch Screen menus. Each of the chosen aspects are monitored independently, and when they fail to meet the vetted standard, a fault condition is issued.

Fault conditions can be monitored with an external alarm system or other device through the 15-pin **Control** connector on the corresponding rear backplane connector. The Form C relays status outputs from this connector can be monitored by a device to show Primary and Secondary signal status and the current position of the protect switch (Primary or Secondary).

Two GPI Override Inputs are available to allow changing switch position in response to triggers from an external source. This can be used to manually reset the switch after the Primary has recovered from a fault condition or set to respond to a signal state from an external device to trigger a switch.

The on-board CPU can monitor and report module ID information (slot location, software version and board revision), and power status to the optional frame System Control module. This information can be accessed by the user or set to register an alarm if desired using the remote control options available.

Every function and parameter on the module can be controlled from an Avenue Touch Screen Control Panel or the Avenue PC Control Application. Memory registers can be used to save the complete configuration of the module, making it easy to change instantly between different configurations.

Modules at software version 2.2.0 or later support SNMP (Simple Network Management Protocol) monitoring. For each applicable signal processing module, module, signal, and reference status are reported. For complete details on using SNMP monitoring, refer to the **Avenue System Overview** in the manual that accompanies each frame.

## APPLICATIONS

### Auto-Switched Upconversion Application

The diagram below shows a typical use for the 7450 module, where it is used to form a fully redundant, auto-switched conversion chain. The Primary input is backed up with a Secondary input from a video server.

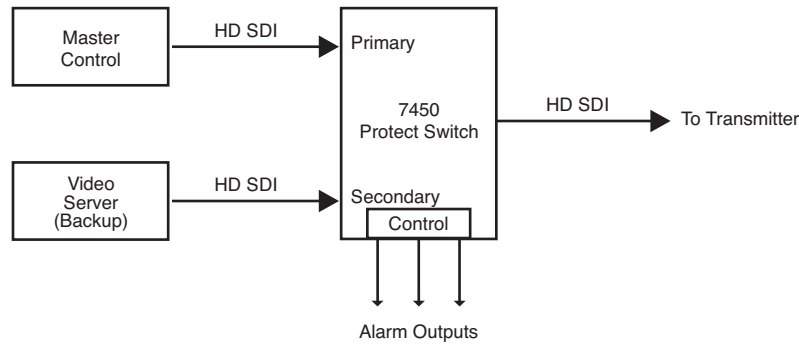

*Redundant Auto-Switched Conversion with 7450 Module*

### Fiber Feed Application

In the example below, a fiber feed goes to an Avenue 3720 optical-to-electrical converter and into the 7450. The 7450 evaluates the HD SDI signal health of both feeds and switches to the Secondary feed if required.

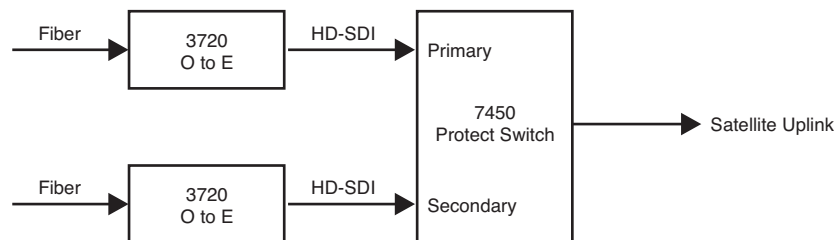

*Fiber Feed with 7450 Module*

### 3RU and 1RU Backplane Diagrams

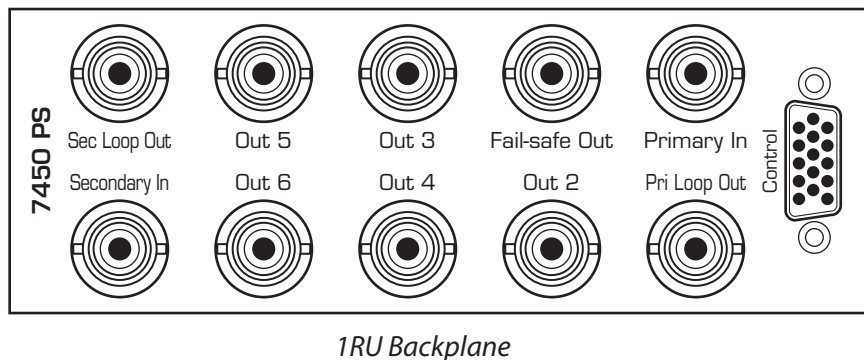
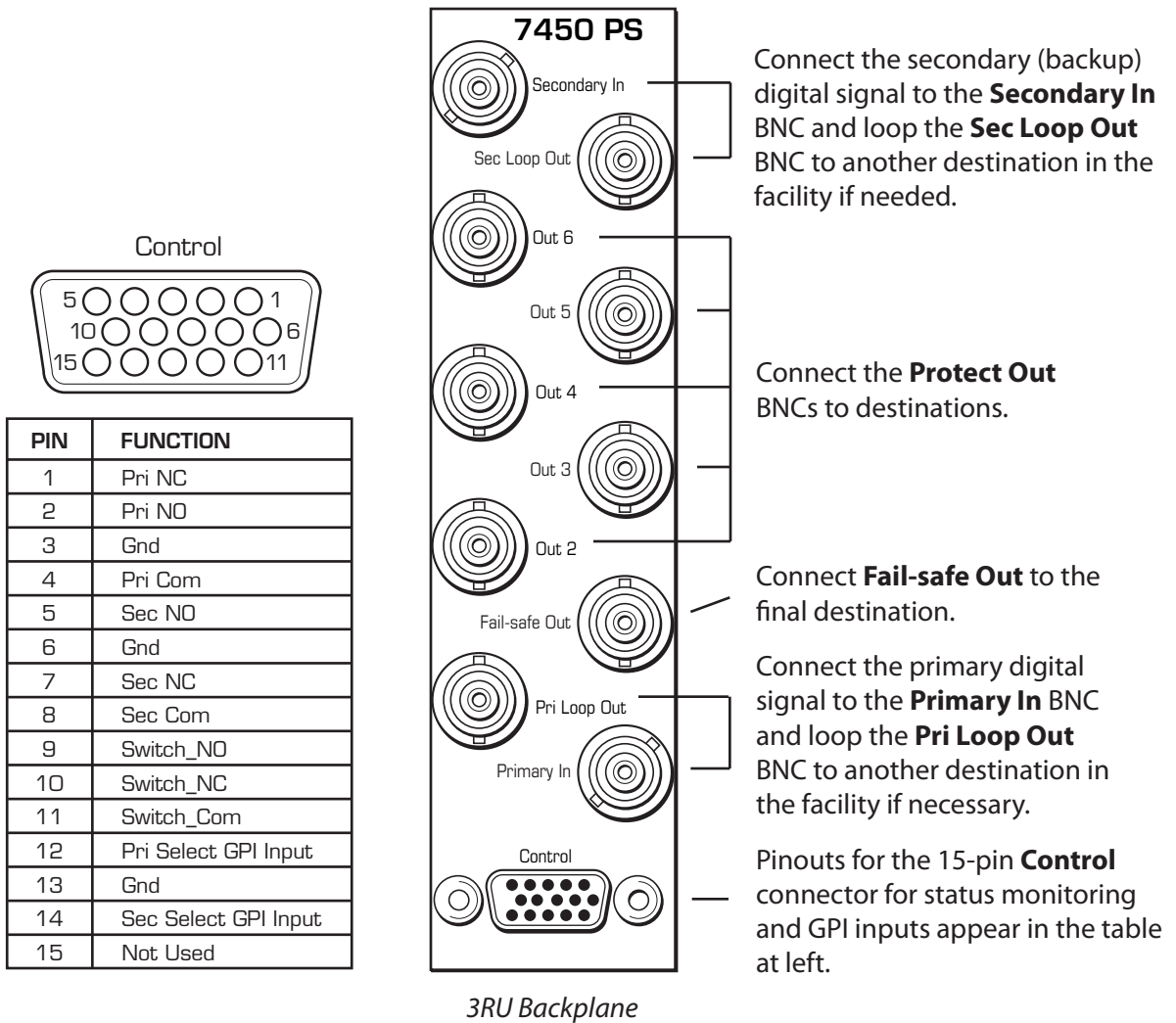



## Status and Alarm Cabling

In addition to full monitoring and access through the control system, the 7450 module provides contact closure status indications through the 15-pin D **Control** connector on the corresponding rear slot of the frame. These connections can drive an alarm system or other external monitoring devices, including LEDs. Two override GPI Inputs can also be accessed through the connector. Pinouts for the status monitoring are given in the preceding illustration.

Form C relay contacts provide both NO (Normally Open) and NC (Normally Closed) switching to indicate fault status of the Primary and Secondary inputs and the protection switch output. Both the NO and NC contacts are simultaneously available on the **Control** connector. Each output is independently strappable to provide Ground, current limited +5V (1k resistor), or a Common which appears on the D connector.

The three relay contacts provide the following status reporting:

- **Primary Good or Failed** – indicates Primary input status as Good when NO contact is active (switched to Common).
- **Secondary Good or Failed** – indicates Secondary input status as Good when NO contact is active (switched to Common).
- **Switch Position** – indicates the position of the protect switch as either Primary or Secondary selected. The normal position corresponds to the Primary feeding the input.

An individual common is provided to each of the relays. For each of the three status relays there is a 3-position jumper on the module which configures the common signal that will be used by that relay. The choices are as follows:

- **COM** – uses the user-provided common signal from the Control connector.
- **+5** – provides a +5V signal through a 1k resistor to the relay common.
- **Gnd** – uses ground as the relay common.

Because both the NO and NC connections are provided, it is possible to have independent status lines for each of the two states of a status signal. For example, if the jumper is set to **+5V**, the Primary NO output will source **+5V** when the relay is in the normal position (Signal Failed) and the Primary NC output will source the **+5V** when the relay is closed (Signal Good). Additionally, in the case of selecting **+5V** as the common, the 1k resistor on the module will act as a current limiter, allowing the direct connection of ordinary LEDs to each of these output pins. A green LED could be connected to the NC output and a red LED to the NO output. This would provide complete and explicit indication to the operator as to the signal status.

Also available through the **Control** connector are two Override GPI inputs that when closed to ground, will force the switch to either Primary or Secondary. The GPI inputs are edge-triggered on a negative pulse, or simply a falling edge. These inputs may also be used to switch back to the Primary after a fault has cleared.

## MODULE CONFIGURATION AND CONTROL

The configuration parameters for each Avenue module must be selected after installation. This can be done remotely using one of the Avenue remote control options or locally using the module front panel controls. Each module has a **REMOTE/LOCAL** switch on the front edge of the circuit board which must first be set to the desired control mode.

The configuration parameter choices for the module will differ between **Remote** and **Local** modes. In **Remote** mode, the choices are made through software and allow more selections. The **7450 Parameter Table** on the following page summarizes and compares the various configuration parameters that can be set remotely or locally and the default/factory settings. It also provides the default User Levels for each control. These levels can be changed using the Avenue PC application.

If you are not using a remote control option, the module parameters must be configured from the front panel switches. Parameters that have no front panel control will be set to a default value. The **Local** switches are illustrated in the **Front Panel Controls and Indicators** section following the **7450 Parameter Table**.

Avenue module parameters can be configured and controlled remotely from one or both of the remote control options, the Avenue Touch Screen or the Avenue PC Application. Once the module parameters have been set remotely, the information is stored on the module CPU. This allows the module be moved to a different cell in the frame at your discretion without losing the stored information. Remote configuration will override the switch settings on the front edge of the module.

For setting the parameters remotely using the Avenue PC option, refer to the **Avenue PC Remote Configuration** section of this document.

For setting the parameters remotely using the Avenue Touch Screen option, refer to the **Avenue Touch Screen Remote Configuration** section of this document.

## 7450 Parameter Table

CONTROL	LOCAL	REMOTE	DEFAULT	USER LEVEL
Auto Reset	On	On Off	On	Admin
Reset Time	15 seconds	0 - 60 seconds	15 seconds	Admin
TRS Test	Switch 1: On Off	Off Lenient Strict	Lenient	Admin
Audio Detect	Switch 3: On Off	On Off	On	Admin
Black Detect	Switch 4: On Off	On Off	On	Admin
Freeze Test/Mode	Switch 5: On Off	Off Clean Source Noisy Source	Off	Admin
Sec Test Enable	On	On Off	On	Admin
Window	Big	Small Big	Big	Admin
Black Time	3 sec	0 - 300 sec	3 sec	Admin
Detect Level	10 IRE	0 - 100 IRE	10 IRE	Admin
Black Fraction	50%	0 - 100%	50%	Admin
Audio Group	Group 1	Group 1 Group 2 Group 3 Group 4	Group 1	Admin
Audio Threshold	-20 VU	0VU -5 VU -10 VU -15 VU -20 VU -25 VU -30 VU -35 VU -40 VU	-20 VU	Admin
Audio Time	3 sec	.5 - 20 sec	3 sec	Admin
Audio Channel enable	Enabled Enabled Disabled Disabled	Ch1 enable/disable Ch2 enable/disable Ch3 enable/disable Ch4 enable/disable	Enabled Enabled Disabled Disabled	Admin
Freeze Mode	Clean Source	Clean Source Noisy Source	Clean Source	Admin
Freeze Time	3 sec	0 - 300 sec	3 sec	Admin

Model 7450 HD Protection Switch

---

CONTROL	LOCAL	REMOTE	DEFAULT	USER LEVEL
PRI GPI Mode	Neg Edge Switch	Off Neg Edge Switch Ext Fault Low Ext Inhibit Low Neg Edge Reg 1	Neg Edge Switch	Admin
Sec GPI Mode	Neg Edge Switch	Off Neg Edge Switch Ext Fault Low Ext Inhibit Low Neg Edge Reg 2	Neg Edge Switch	Admin
Memory Registers	Last Saved	1 - 5	Last Saved	Level 1

## Front Panel Controls and Indicators

Each front edge indicator and switch setting of the 7450 is shown in the diagram below:

**Pri In OK** green LED:

**ON** when Primary input passes all enabled tests.  
**OFF** when Primary input fails an enabled test.

**Pri Active** green LED:

**ON** when Primary input is feeding the output.  
**OFF** when Primary input is not feeding the output.

**Control** Switch:

Momentary switch to set output to Primary (Up) or Secondary (Down).

**Remote/Local** switch:

Set to the mode you will use.

**Run** green LED:

**OFF** A power fault or halted CPU  
**ON** A halted CPU  
**FAST BLINK** CPU Run error  
**SLOW BLINK** System OK. (If SPI control is active from the main frame System Control Module, all Run indicators will be synchronized.)

**Pwr** green LED:

Indicates the presence (**ON**) or absence (**OFF**) of power (+5V).

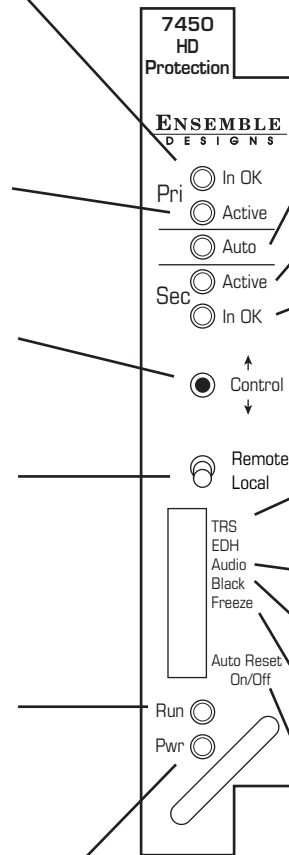

**Auto** green LED:

**ON** when Auto is active.  
**OFF** when Auto is turned off.

**Sec Active** red LED:

**ON** when Secondary input is feeding the output.  
**OFF** when Secondary input is not feeding the output.

**Sec In OK** green LED:

**ON** when Secondary input passes all enabled tests.  
**OFF** when Secondary input fails an enabled test.

**TRS** switch:

Select **On** (left) to monitor for TRS error condition as fault or **Off** (right) for no TRS testing.

**Audio** switch:

Select **On** (left) to detect audio silence condition as fault or **Off** (right) for no audio detection.

**Black** switch:

Select **On** (left) to detect black condition as fault or **Off** (right) for no black detection.

**Freeze** switch:

Select **On** (left) to detect freeze condition as fault or **Off** (right) for no freeze detection.

**Auto Reset** switch:

Select **On** (left) to enable module to auto reset when Primary input is restored or **Off** (right) for manual reset when Primary input is restored.

## AVENUE PC REMOTE CONFIGURATION

The Avenue PC remote control status menus for the 7450 module are illustrated and explained below. Refer to the **7450 Parameter Table** for a summary of available parameters that can be set remotely through the menus illustrated. For more information on using Avenue PC, refer to the Avenue PC Control Application Software data pack that came with the option.

Parameter fields that are grayed out can indicate one of the following conditions:

- An option is not installed.
- The function is not active.
- The module is locked.
- The User Level set with Avenue PC is not accessible from the current User Level.

### 7450 Avenue PC Menus

#### Status Menu

The **Status** menu screen shown below displays overall status of selected parameters on both the Primary and Secondary inputs as Green = Good, Red = Bad, Gray = Not enabled. It allows you to set the **Auto Reset** and **Reset Time** controls for the switching function.

- **Pri Status** – shows the status of the Primary input's Timing Reference Signal (**TRS**), embedded audio present and correct (**Aud**), black detected as defined in the **Black Detect** menu (**Blk**), and if frozen video is detected as defined in the **Freeze** menu (**Frz**).

The **Pri Status** window on the right will display the status of the Primary and can be monitored with the Avenue PC alarm function.

- **Sec Status** – shows the status of the Secondary input's Timing Reference Signal (**TRS**), embedded audio present and correct (**Aud**), and black detected as defined in the **Black Detect** menu (**Blk**), and if frozen video is detected as defined in the **Freeze** menu (**Frz**).

The **Sec Status** window on the right will display the status of the Secondary and can be monitored with the Avenue PC alarm function.

- **Switch Pos** – the status window will indicate the current position of the protect switch. This window can be monitored by the Avenue PC alarm function.
- **Pri** – lights green when the Primary input is selected to the output. Click this control to select the Primary as the output.
- **Auto** – lights green when **Auto** is turned on. Switch **Auto** on and off with this switch control. When **Auto** is on, the module will automatically switch to the Secondary input if the Primary fails and the Secondary is good.
- **Sec** – lights red when the Secondary input is selected to the output. Press this switch control to select the Secondary as the output.

- **Auto Reset** – set to **On** or **Off** to determine if the switch will automatically switch back to the Primary after it recovers.
- **Reset Time** – set the amount of time the Primary signal must be good before the auto reset switches back to Primary from Secondary.

Status	Config	Blk Detect	Aud Detect	Freeze	Pri Errors	Sec Errors	GPI	Inputs	Memory
<b>Pri Status</b> TRS <input checked="" type="checkbox"/> ... <input type="checkbox"/> Aud <input type="checkbox"/> Blk <input type="checkbox"/> Frz <input type="checkbox"/>					<b>Pri Status</b> Signal Good				
<b>Sec Status</b> TRS <input checked="" type="checkbox"/> ... <input type="checkbox"/> Aud <input type="checkbox"/> Blk <input type="checkbox"/> Frz <input type="checkbox"/>					<b>Sec Status</b> Signal Good				
<b>Pri</b> <input checked="" type="checkbox"/>		<b>Auto</b> <input checked="" type="checkbox"/>		<b>Sec</b> <input type="checkbox"/>			<b>Switch Pos</b> Primary		
<b>Auto Reset</b> On				<b>Reset Time</b> ← → 15 secs					

## Config Menu

The **Config** menu shown below allows you to configure the various condition detectors:

- **TRS Test** – enables the test for any Timing Reference Signal (TRS) errors. **Off** sets the input for no TRS test, **Lenient** allows occasional TRS errors to be ignored (10 frames in a row), or **Strict** detects any TRS error as a fault.
- **Audio Detect** – enables the test for embedded audio. **On** detects an audio condition as determined by the settings made in the **Aud Detect** menu, or **Off** sets the input for no audio test.
- **Black Detect** – enables the test for black detection. **On** detects black present as defined by the settings made in the **Blk Detect** menu, or **Off** sets the input for no black test.
- **Freeze Test** – **On** enables the test for a freeze condition as determined by the settings chosen in the **Freeze** menu. Set to **Off** for no freeze test.
- **Sec Test Enable** – enables the test for checking the status of the Secondary input. When **On**,

The screenshot shows a software interface with a menu bar at the top containing the following items: Status, Config, Blk Detect, Aud Detect, Freeze, Pri Errors, Sec Errors, GPI, Inputs, and Memory. The 'Config' menu is currently selected. Below the menu bar, there are five dropdown menus arranged in two rows. The first row contains 'TRS Test' (set to 'Lenient') and 'Audio Detect' (set to 'Off'). The second row contains 'Black Detect' (set to 'Off'), 'Freeze Test' (set to 'Off'), and 'Sec Test Enable' (set to 'On').



## Blk Detect Menu

The **Blk Detect** menu shown below allows you to configure the following black detector parameters:

- **Window** – select **Big** or **Small**. **Big** examines nearly the entire raster. **Small** limits the test to a smaller portion of the raster (somewhat smaller than Safe Title limits).
- **Blk Time** – select the amount of time from one frame to 300 seconds that the signal must be continuously in black before the protect switch (and alarm) is generated.
- **Detect Level** – set the video value from 0 to 100 IRE, below which a pixel is considered to be black.
- **Blk Frac** – set the percentage of pixels in the detection window that must satisfy the detection level parameter.

The following status displays are also provided and can be monitored with Avenue PC alarms:

- **Pri Valid** – shows the portion of the Primary input which currently exceeds the **Detect Level** parameter. This display tracks the actual video content.
- **Sec Valid** – shows the portion of the Secondary input which currently exceeds the **Detect Level** parameter. This display tracks the actual video content.

The screenshot shows a software interface with a menu bar at the top containing: Status, Config, Blk Detect, Aud Detect, Freeze, Pri Errors, Sec Errors, GPI, Inputs, and Memory. The 'Blk Detect' menu is active. Below the menu bar, there are several control panels:

- Window:** A dropdown menu currently set to 'Big'.
- Blk Time:** A control panel with left and right arrow buttons and a numeric input field containing '3', followed by the unit 'secs'.
- Detect Level:** A control panel with left and right arrow buttons and a numeric input field containing '10', followed by the unit 'IRE'.
- Blk Frac:** A control panel with left and right arrow buttons and a numeric input field containing '5', followed by the unit 'pcnt'.
- Pri Valid:** A control panel with a numeric input field containing '.2', followed by the unit 'pcnt'.
- Sec Valid:** A control panel with a numeric input field containing '0', followed by the unit 'pcnt'.

## Aud Detect Menu

The **Aud Detect** menu shown below allows you to configure the following audio parameters:

- **Audio Group** – select which embedded audio group (**Group 1 – 4**) to detect.
- **Aud Thrsh** – select the silence detection level from 0 VU to –40 VU.

**Note:** An audio signal level of 0 VU corresponds to -20dBFs and is the generally accepted digital reference level for AES audio. The 7450 uses the standard weighting and ballistics of VU (Volume Unit) measurement rather than decibel-based measurement in order to more closely represent audio levels as perceived by the listener.

- **Audio Time** – set the time that the channels must be continuously silent before an alarm is triggered (0 – 20 seconds). Note that a loss of embedded audio will cause an immediate switch, regardless of this setting.
- **Ch1, Ch2, Ch3, Ch4** – enable or disable Channels 1 – 4. Each embedded group contains four audio channels. Sensing for each channel can be enabled separately.

The following status displays are also provided:

- **Pri Status** – shows the status of the four audio channels embedded in the Primary signal. Green indicates Channel OK, red indicates silence, and gray indicates channel not enabled. An **OK** indicator shows the overall result of the test for all the channels enabled.
- **Sec Status** – shows the status of the four audio channels embedded in the Secondary signal. Green indicates Channel OK, red indicates silence, and gray indicates channel not enabled. An **OK** indicator shows the overall result of the test for all the channels enabled.
- **Pri Aud Status** – shows the overall status of the audio channels embedded in the Primary signal. This window can be monitored by the Avenue PC alarm function.

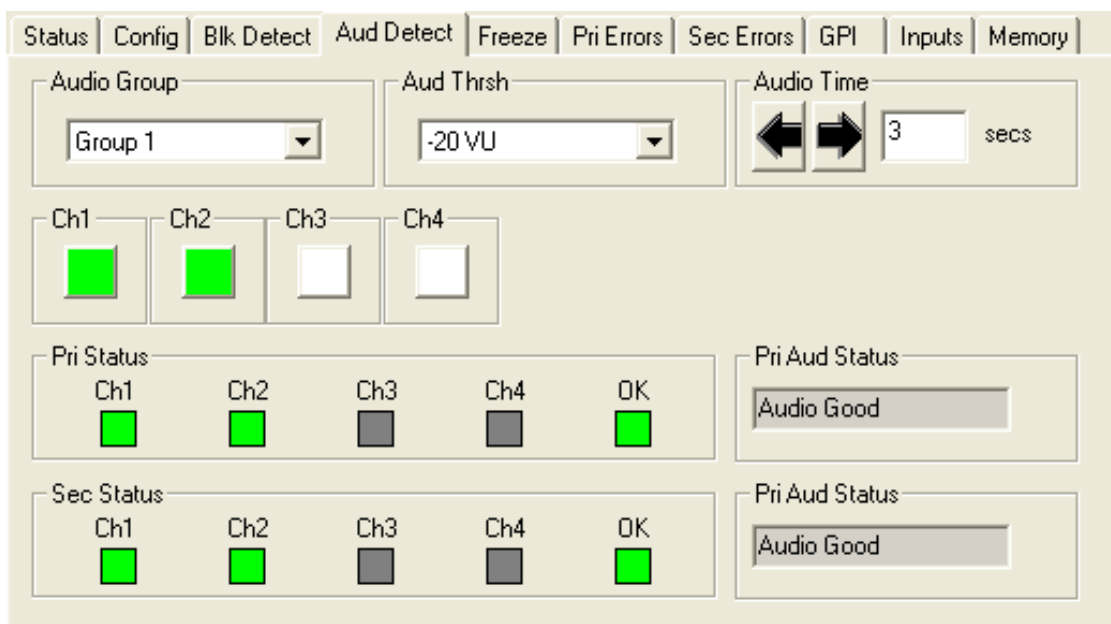

## Freeze Menu

The **Freeze** menu shown below allows you to configure the following parameters for a video freeze condition:

- **Freeze Mode** – set the freeze detection to **Clean Source**, **Noisy Source**, or **Off**.
- **Freeze Time** – set the amount of time in seconds for the protect switch to switch to the Secondary input after a video freeze condition is detected.

The following status indicators can be monitored by Avenue PC alarm functions.

- **Pri Frz Status** – indicates the freeze status of the Primary as **Frozen** or **Unfrozen**.
- **Sec Frz Status** – indicates the freeze status of the Secondary as **Frozen** or **Unfrozen**.

**Note:** If either **Noisy Source** or **Clean Source** are selected, and Freeze test is set to **Off** in the **Configuration** menu, use of Avenue PC alarms is allowed without activating a switch to the Secondary Source. Primary and Secondary Freeze Error Counts are then active.

The screenshot shows a software interface with a menu bar at the top containing: Status, Config, Blk Detect, Aud Detect, Freeze, Pri Errors, Sec Errors, GPI, Inputs, Memory. The 'Freeze' menu is active, displaying the following controls:

- Freeze Mode:** A dropdown menu currently set to 'Clean Source'.
- Freeze Time:** A control with left and right arrow buttons, a numeric input field containing '3', and the unit 'secs'.
- Pri Frz Status:** A status indicator box showing 'Frozen'.
- Sec Frz Status:** A status indicator box showing 'Frozen'.

## Pri Errors Menu

The **Pri Errors** menu shown below displays the amount of time in seconds that each of the error conditions have been present after detection on the Primary as well as the number of times the Primary feed has switched to the Secondary feed (**Sec Sw Cnt**).

The error counters display the number of *cumulative* errors that have occurred since a counter was last reset. Errors may occur as a single event, or as multiple events over a period of time. Refer to the Avenue PC manual to learn how to use the alarms and logging capabilities of Avenue PC to obtain more detailed information on errors.

The upper limit for cumulative errors is 10,000. If an error counter reaches this upper limit, it will repeatedly cycle between 10,000 and 9,999. To reset the error counter, double-click it.

The screenshot shows a software interface with a menu bar at the top containing the following items: Status, Config, Blk Detect, Aud Detect, Freeze, Pri Errors (highlighted), Sec Errors, GPI, Inputs, and Memory. Below the menu bar, there are five error counter fields arranged in two rows. Each field consists of a text box containing a numerical value and the label 'Cnt' to its right.

Counter Name	Value
TRS ErrSec	0
BLK ErrSec	740
AUD ErrSec	218
FRZ ErrSec	738
Sec Sw Cnt	0

## Sec Errors Menu

The **Sec Errors** menu shown below displays the amount of time in seconds that each of the enabled error conditions have been present after detection on the Secondary as well as the number of times the Primary feed has switched to the Secondary feed (**Sec Sw Cnt**).

Status	Config	Blk Detect	Aud Detect	Freeze	Pri Errors	Sec Errors	GPI	Inputs	Memory
TRIS ErrSec									
<input type="text" value="230"/> Cnt									
BLK ErrSec									
<input type="text" value="10000"/> Cnt									
AUD ErrSec									
<input type="text" value="229"/> Cnt									
FRZ ErrSec									
<input type="text" value="10000"/> Cnt									
Sec Sw Cnt									
<input type="text" value="0"/> Cnt									

## GPI Menu

The 7450 can be set up to allow an external device to trigger a switch through the GPI interface. The **GPI** menu screen shown below allows configuration of the two external GPI inputs to the module.

The Primary and Secondary GPI Modes can be set to one of the following:

- **Off** – disables the GPI input.
- **Neg Edge Switch** – switches on a low-going transition to the GPI input.
- **Ext Fault Low** – acts in conjunction with the status of the input signal to the module. In this case, a loss of proper signal to the module or a low signal detected from an external device will close the switch.
- **Ext Inhibit Low** – acts to prevent a switch regardless of the status of the input signal to the module. In this case, a loss of proper signal will not cause a switch.

Status of the Pri GPI and Sec GPI inputs are indicated as **GPI is Low** or **GPI is High** in the **Pri GPI** and **Sec GPI Status** window.



## Inputs Menu

The **Inputs** menu displays the type of signal detected on the Primary and Secondary inputs.

- **Primary Input** displays the HD SDI signal type detected on the Primary Input connector.
- **Secondary Input** displays the HD SDI signal type detected on the Secondary Input connector.

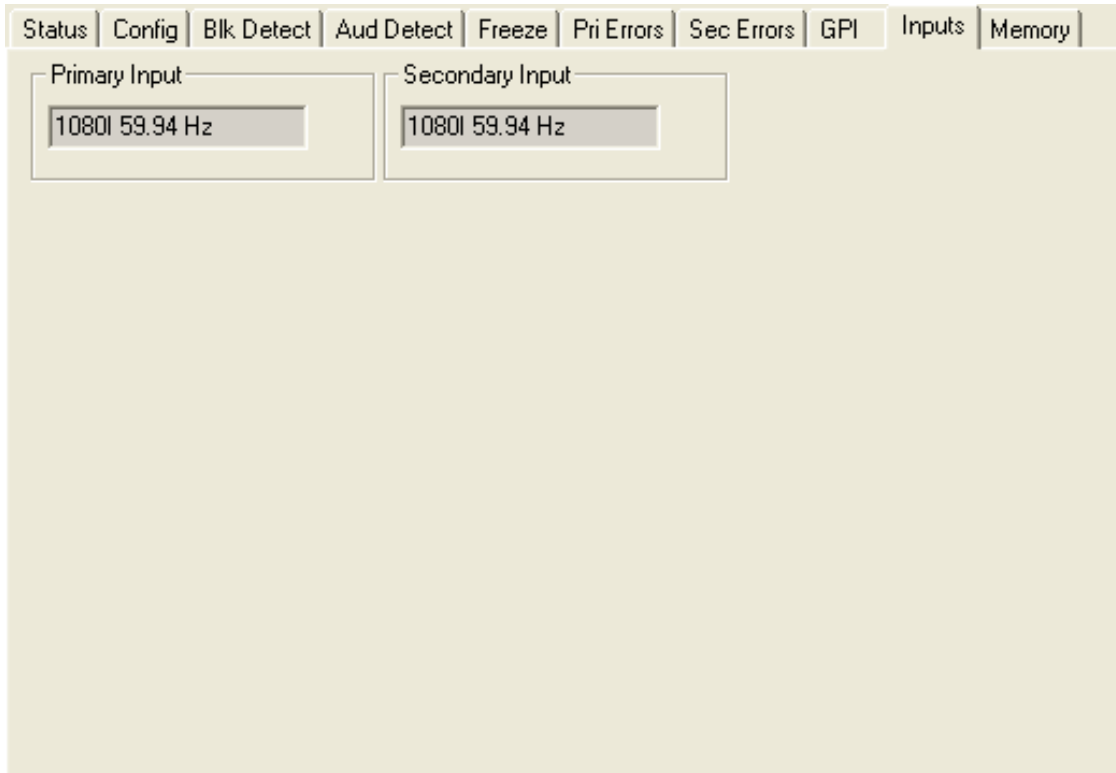

## Memory Menu

The **Memory** menu allows you to save and recall up to 5 different setups for the 7450 module as follows:

- Click **Save**, then one of the five memory registers **Reg 1** – **5**. The box will turn green. The entire module setup is now saved in the selected register.
- To recall a setup, click the register box. If there is information saved, the box will turn green. The saved setup will load into the module.

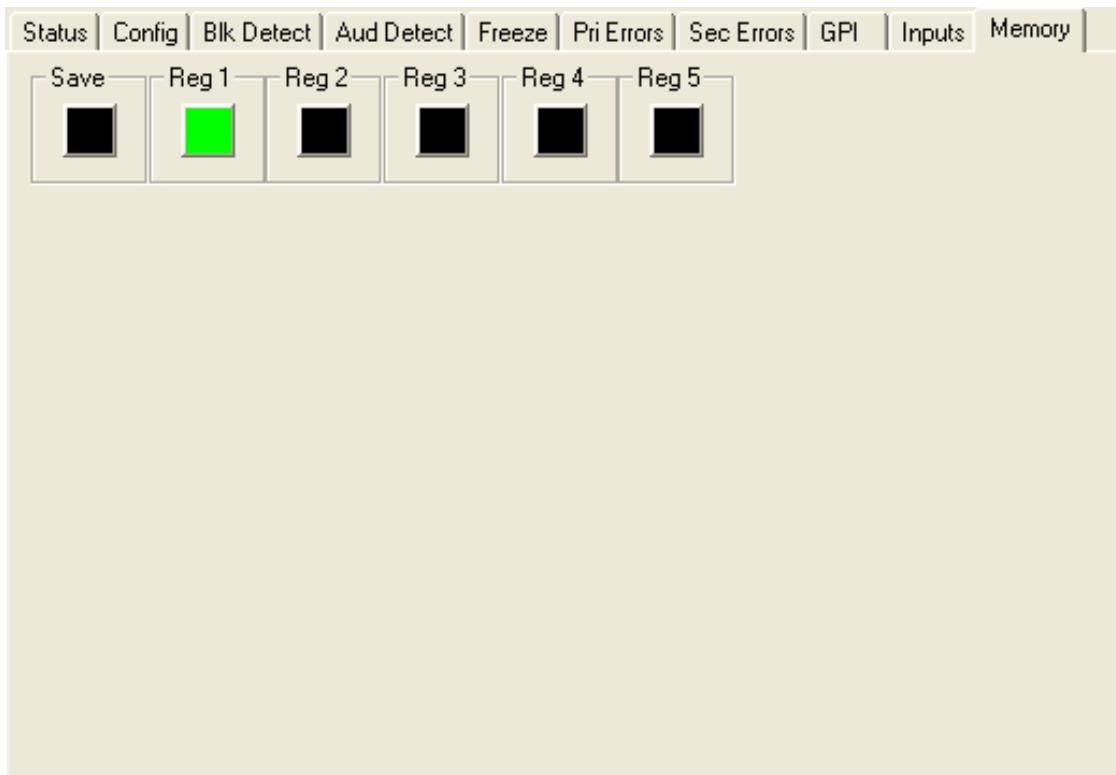



## AVENUE TOUCH SCREEN REMOTE CONFIGURATION

The Avenue Touch Screen remote control status menus for this module are illustrated and explained below. Refer to the **7450 Parameter Table** for a summary of available parameters that can be set remotely through the menus illustrated. For more information on using Avenue Touch Screen, refer to the Avenue Touch Screen data pack.

Parameter fields that are grayed out can indicate one of the following conditions:

- An option is not installed.
- The function is not active.
- The module is locked.
- The User Level set with Avenue PC is not accessible from the current User Level.

### 7450 Avenue Touch Screen Menus

#### Status Menu

The **Status** menu screen shown below displays overall status of selected parameters on both the Primary and Secondary inputs as Green = Good, Red = Bad, Gray = Not enabled. It allows you to set the **Auto Reset** and **Reset Time** controls for the switching function.

- **Pri Status** – shows the status of the Primary input's Timing Reference Signal (**TRS**), embedded audio present and correct (**Aud**), black detected as defined in the **Black Detect** menu (**Blk**), and if frozen video is detected as defined in the **Freeze** menu (**Frz**).

The **Pri Status** window on the right will display the status of the Primary and can be monitored with the Avenue PC alarm function.

- **Sec Status** – shows the status of the Secondary input's Timing Reference Signal (**TRS**), embedded audio present and correct (**Aud**), and black detected as defined in the **Black Detect** menu (**Blk**), and if frozen video is detected as defined in the **Freeze** menu (**Frz**).

The **Sec Status** window on the right will display the status of the Secondary and can be monitored with the Avenue PC alarm function.

- **Switch Pos** – the status window will indicate the current position of the protect switch. This window can be monitored by the Avenue PC alarm function.
- **Pri** – lights green when the Primary input is selected to the output. Click this control to select the Primary as the output.
- **Auto** – lights green when **Auto** is turned on. Switch **Auto** on and off with this switch control. When **Auto** is on, the module will automatically switch to the Secondary input if the Primary fails and the Secondary is good.

- **Sec** – lights red when the Secondary input is selected to the output. Press this switch control to select the Secondary as the output.
- **Auto Reset** – set to **On** or **Off** to determine if the switch will automatically switch back to the Primary after it recovers.
- **Reset Time** – set the amount of time the Primary signal must be good before the auto reset switches back to Primary from Secondary.

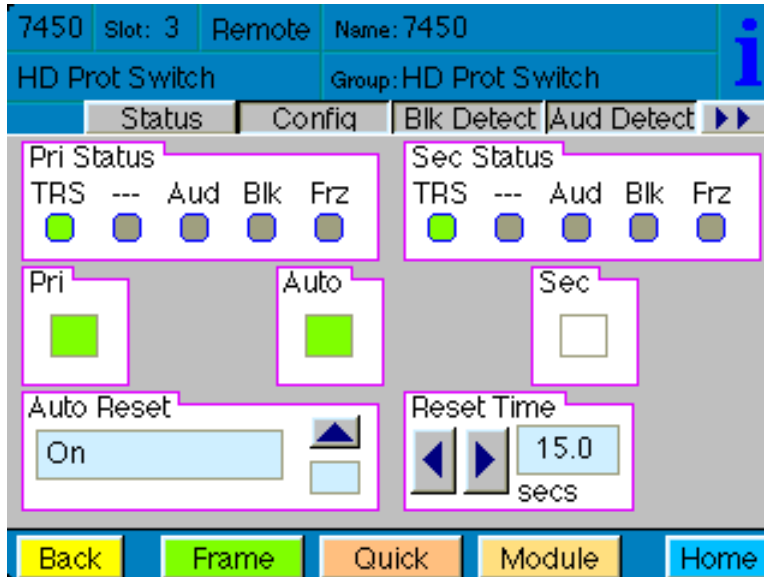

## Config Menu

The **Config** menu shown below allows you to configure the various condition detectors:

- **TRS Test** – enables the test for any Timing Reference Signal (TRS) errors. **Off** sets the input for no TRS test, **Lenient** allows occasional TRS errors to be ignored (10 frames in a row), or **Strict** detects any TRS error as a fault.
- **Audio Detect** – enables the test for embedded audio. **On** detects an audio condition as determined by the settings made in the **Aud Detect** menu, or **Off** sets the input for no audio test.
- **Black Detect** – enables the test for black detection. **On** detects black present as defined by the settings made in the **Blk Detect** menu, or **Off** sets the input for no black test.
- **Freeze Test** – **On** enables the test for a freeze condition as determined by the settings chosen in the **Freeze** menu. Set to **Off** for no freeze test.
- **Sec Test Enable** – enables the test for checking the status of the Secondary input. When **On**, the Secondary status will be checked for the same configuration tests as assigned for the

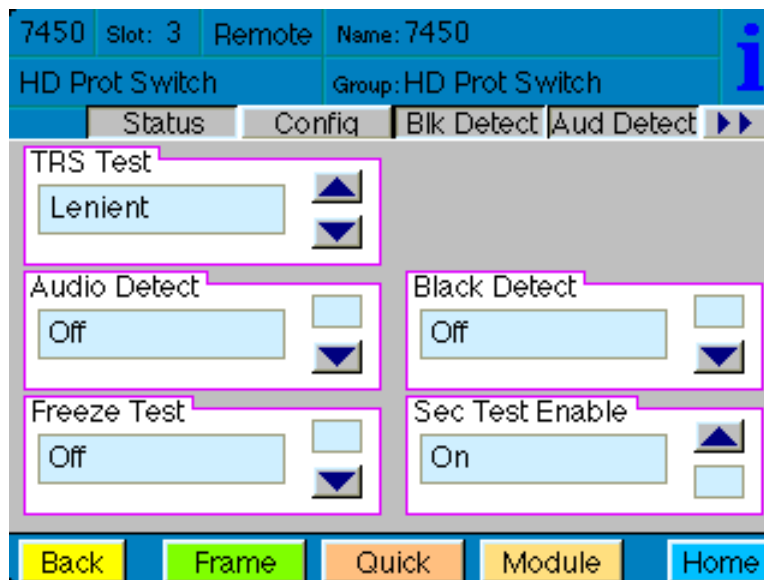

## Blk Detect Menu

The **Blk Detect** menu shown below allows you to configure the following black detector parameters:

- **Window** – select **Big** or **Small**. **Big** examines nearly the entire raster. **Small** limits the test to a smaller portion of the raster (somewhat smaller than Safe Title limits).
- **Blk Time** – select the amount of time from one frame to 300 seconds that the signal must be continuously in black before the protect switch (and alarm) is generated.
- **Detect Level** – set the video value from 0 to 100 IRE, below which a pixel is considered to be black.
- **Blk Frac** – set the percentage of pixels in the detection window that must satisfy the detection level parameter.

The following status displays are also provided and can be monitored with Avenue PC alarms:

- **Pri Valid** – shows the portion of the Primary input which currently exceeds the **Detect Level** parameter. This display tracks the actual video content.
- **Sec Valid** – shows the portion of the Secondary input which currently exceeds the **Detect Level** parameter. This display tracks the actual video content.

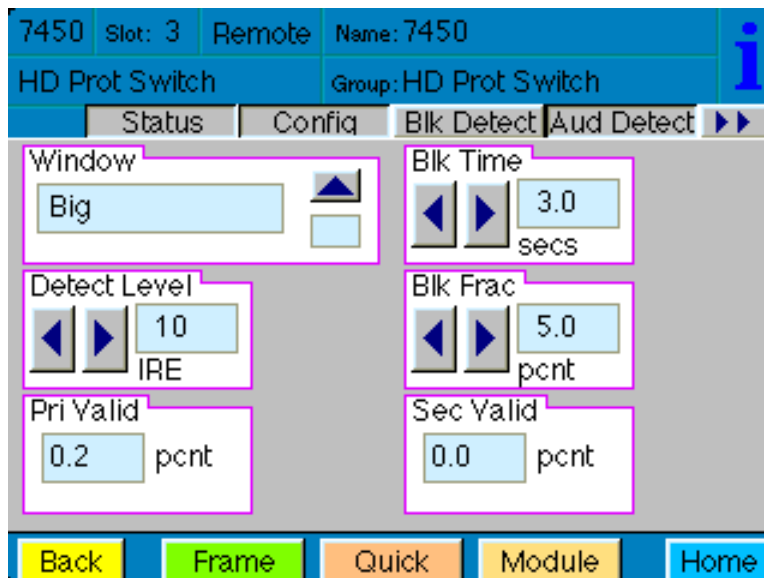

## Aud Detect Menu

The **Aud Detect** menu shown below allows you to configure the following audio parameters:

- **Audio Group** – select which embedded audio group (**Group 1 – 4**) to detect.
- **Aud Thrsh** – select the silence detection level from 0 VU to –40 VU.

**Note:** An audio signal level of 0 VU corresponds to -20dBFs and is the generally accepted digital reference level for AES audio. The 7450 uses the standard weighting and ballistics of VU (Volume Unit) measurement rather than decibel-based measurement in order to more closely represent audio levels as perceived by the listener.

- **Audio Time** – set the time that the channels must be continuously silent before an alarm is triggered (0 – 20 seconds). Note that a loss of embedded audio will cause an immediate switch, regardless of this setting.
- **Ch1, Ch2, Ch3, Ch4** – enable or disable Channels 1 – 4. Each embedded group contains four audio channels. Sensing for each channel can be enabled separately.

The following status displays are also provided:

- **Pri Status** – shows the status of the four audio channels embedded in the Primary signal. Green indicates Channel OK, red indicates silence, and gray indicates channel not enabled. An **OK** indicator shows the overall result of the test for all the channels enabled.
- **Sec Status** – shows the status of the four audio channels embedded in the Secondary signal. Green indicates Channel OK, red indicates silence, and gray indicates channel not enabled. An **OK** indicator shows the overall result of the test for all the channels enabled.
- **Pri Aud Status** – shows the overall status of the audio channels embedded in the Primary signal. This window can be monitored by the Avenue PC alarm function.

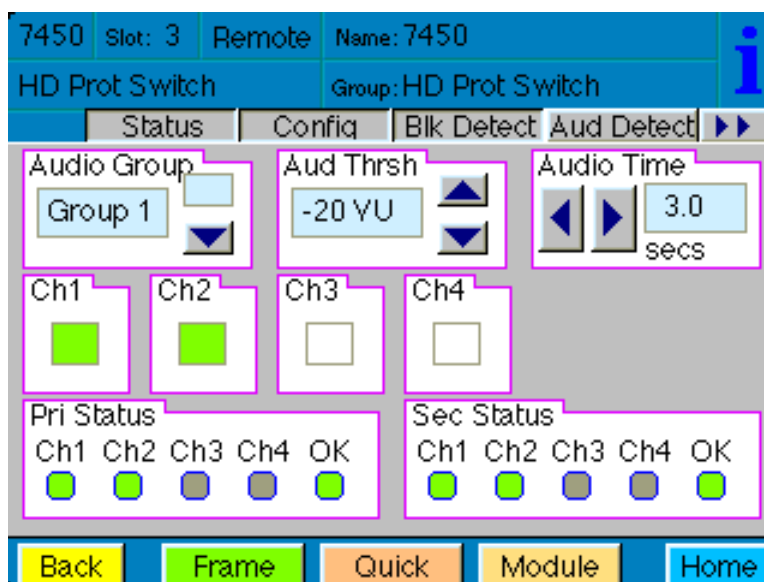

## Freeze Menu

The **Freeze** menu shown below allows you to configure the following parameters for a video freeze condition:

- **Freeze Mode** – set the freeze detection to **Clean Source**, **Noisy Source**, or **Off**.
- **Freeze Time** – set the amount of time in seconds for the protect switch to switch to the Secondary input after a video freeze condition is detected.

The following status indicators can be monitored by Avenue PC alarm functions.

- **Pri Frz Status** – indicates the freeze status of the Primary as **Frozen** or **Un-Frozen**.
- **Sec Frz Status** – indicates the freeze status of the Secondary as **Frozen** or **Un-Frozen**.

**Note:** If either **Noisy Source** or **Clean Source** are selected, and Freeze test is set to **Off** in the **Configuration** menu, use of Avenue PC alarms is allowed without activating a switch to the Secondary Source. Primary and Secondary Freeze Error Counts are then active.

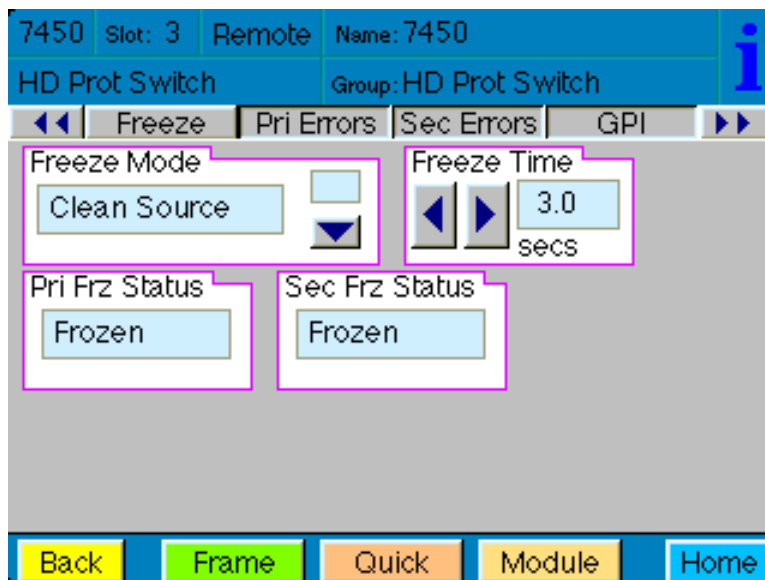

## Pri Errors Menu

The **Pri Errors** menu shown below displays the amount of time in seconds that each of the error conditions have been present after detection on the Primary as well as the number of times the Primary feed has switched to the Secondary feed (**Sec Sw Cnt**).

The error counters display the number of *cumulative* errors that have occurred since a counter was last reset. Errors may occur as a single event, or as multiple events over a period of time. Refer to the Avenue PC manual to learn how to use the alarms and logging capabilities of Avenue PC to obtain more detailed information on errors.

The upper limit for cumulative errors is 10,000. If an error counter reaches this upper limit, it will repeatedly cycle between 10,000 and 9,999. To reset the error counter to 0, touch the field.

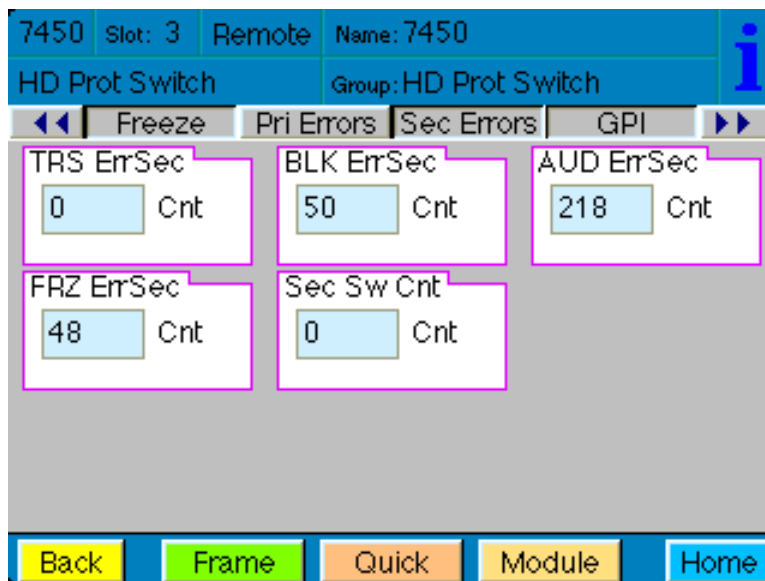

### Sec Errors Menu

The **Sec Errors** menu shown below displays the amount of time in seconds that each of the enabled error conditions have been present after detection on the Secondary as well as the number of times the Primary feed has switched to the Secondary feed (**Sec Sw Cnt**).

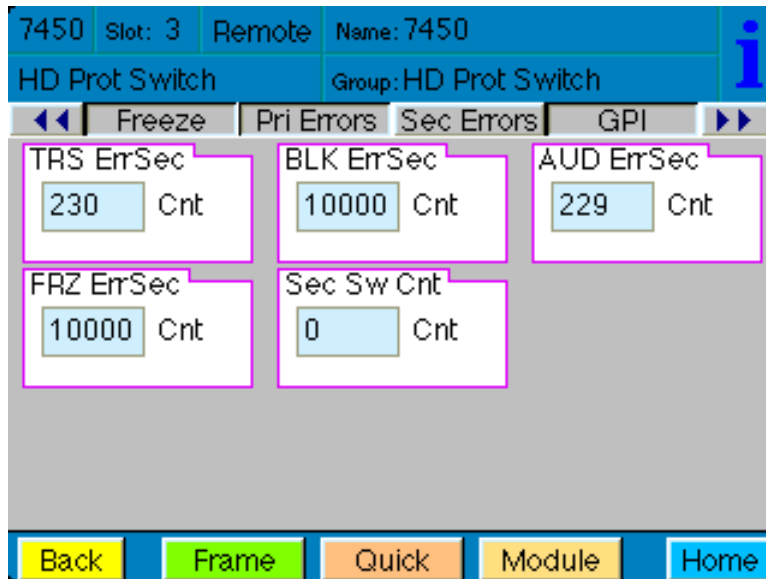



## GPI Menu

The 7450 can be set up to allow an external device to trigger a switch through the GPI interface. The **GPI** menu screen shown below allows configuration of the two external GPI inputs to the module.

The Primary and Secondary GPI Modes can be set to one of the following:

- **Off** – disables the GPI input.
- **Neg Edge Switch** – switches on a low-going transition to the GPI input.
- **Ext Fault Low** – acts in conjunction with the status of the input signal to the module. In this case, a loss of proper signal to the module or a low signal detected from an external device will close the switch.
- **Ext Inhibit Low** – acts to prevent a switch regardless of the status of the input signal to the module. In this case, a loss of proper signal will not cause a switch.

Status of the Pri GPI and Sec GPI inputs are indicated as **GPI is Low** or **GPI is High** in the **Pri GPI** and **Sec GPI Status** window.

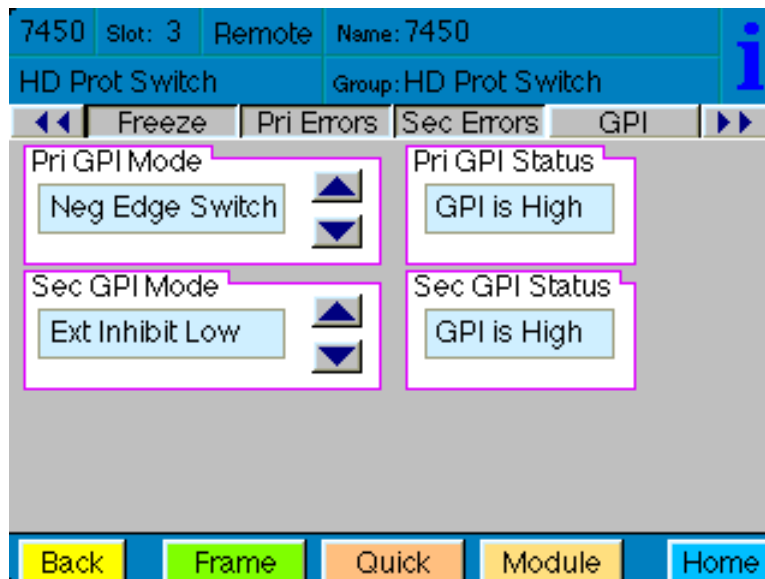

## Inputs Menu

The **Inputs** menu displays the type of signal detected on the Primary and Secondary inputs.

- **Primary Input** displays the HD SDI signal type detected on the Primary Input connector.
- **Secondary Input** displays the HD SDI signal type detected on the Secondary Input connector.

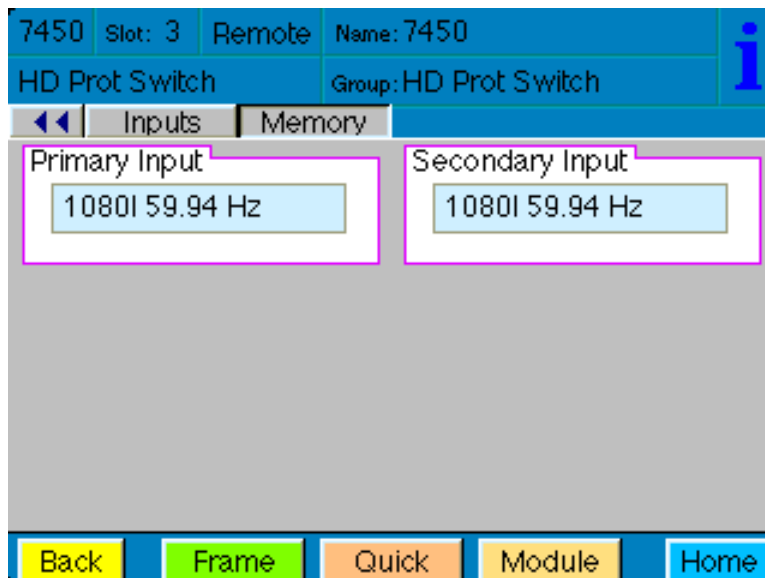

## Memory Menu

The **Memory** menu allows you to save and recall up to 5 different setups for the 7450 module as follows:

- Select **Save**, then one of the five memory registers **Reg 1 – 5**. The box will turn green. The entire module setup is now saved in the selected register.
- To recall a setup, select the register box. If there is information saved, the box will turn green. The saved setup will load into the module.

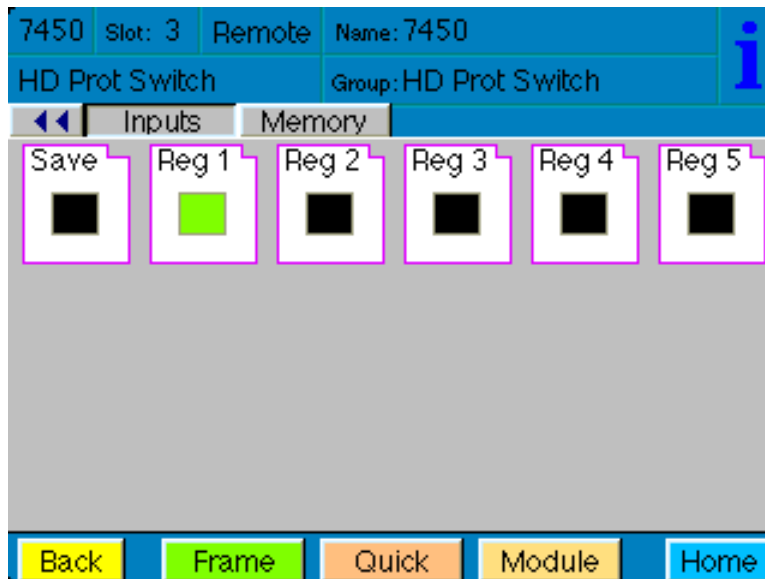

## TROUBLESHOOTING

As a troubleshooting aid, reference signal status and presence, as well as power and CPU status can be easily monitored from the front panel of the 7450 module using the front panel indicators.

Refer to the troubleshooting tips below:

### **Can't control module**

- Check status of CPU Run green LED. Should be blinking slowly and in unison with other modules if System module is present. If not, try removing it and plugging it in again to be sure it is seated properly.
- System module may not be working properly if installed.

### **Module remote controls are grayed out**

- Module is locked or access to module controls is restricted by User Level.

### **No signal out of module**

- Check status of Active LEDs. Primary or Secondary should be lit. If not, check the inputs for signal presence and quality.
- Check cabling to input of the module.

Please also refer to the technical support section of the Ensemble Designs web site for the latest information on your equipment at the URL below:

<http://www.ensembledesigns.com/support>

## SOFTWARE UPDATES

Software updates for each module can be downloaded remotely if the optional System Control module is installed. These can be downloaded onto your PC, then Avenue PC will distribute the update to the individual module. (Refer to the Avenue PC documentation for more information) Updates are periodically posted on the Ensemble Designs web site. If you do not have the required System Control Module and Avenue PC, modules can be sent back to the factory for software upgrades.

## **WARRANTY AND FACTORY SERVICE**

### **Warranty**

This product is covered by a five year limited warranty. If you require service (under warranty or not), please contact Ensemble Designs and ask for customer service before you return this product. This will allow the service technician to provide any other suggestions for identifying the problem and recommend possible solutions.

### **Factory Service**

If you return equipment for repair, please get a Return Material Authorization Number (RMA) from the factory first.

Ship the product and a written description of the problem to:

Ensemble Designs, Inc.  
Attention: Customer Service RMA #####  
870 Gold Flat Rd.  
Nevada City, CA. 95959 USA

(530) 478-1830  
Fax: (530) 478-1832

[service@ensembledesigns.com](mailto:service@ensembledesigns.com)

<http://www.ensembledesigns.com>

Be sure to put your RMA number on the outside of the box.

## SPECIFICATIONS

### Serial Digital Input

Number	Two
Signal Type	HD Serial Digital 1.485 Gb/s SMPTE 274M, 292M or 296M
Max Cable Length	100 Meters (Belden 1694A or equiv.)

### HD Standards Supported

1080i (SMPTE 274M -4, 5, 6)	50, 59.94 or 60 Hz
720p (SMPTE 296M -1, 2, 3)	59.94 or 60 Hz
1080p (SMPTE 274M -9, 10, 11)	23.98, 24, 25 Hz
1080sF (RP211 -14, 15, 16)	23.98, 24, 25 Hz

### Serial Digital Loopback

Number	Two total One primary One secondary
Impedance	75 $\Omega$

### Serial Output Signal

Number	Six total One Fail-safe bypass output Five DA outputs
Signal Type	HD Serial Digital Follows input
Impedance	75 $\Omega$

### General Specifications

Power Consumption	<7.0 watts
Temperature Range	0 to 40°C ambient (all specs met)
Relative Humidity	0 to 95% noncondensing
Altitude	0 to 10,000 ft
Fusing	4 each 0.75 Amp PTC resettable fuse with each domain of the module independently regulated