

**AVENUE**

Avenue™ signal integration system

# Model 6020 Four Channel 20-bit Audio DAC Data Pack

**GRAHAM-PATTEN**  
*The sound choice.*

Revision 3.1 SW v1.0.0

This data pack provides detailed installation, configuration and operation information for the **Model 6020 Four Channel 20-bit Audio Digital to Analog Converter (DAC)** module as part of the Avenue Signal Integration System.

The module information in this data pack is organized into the following sections:

- Module Overview
- Applications
- Installation
- Cabling
- Module Configuration and Control
  - Front Panel Controls and Indicators
  - Avenue PC Remote Control
  - Avenue Touch Screen Remote Control
- Troubleshooting
- Software Updating
- Warranty and Factory Service
- Specifications

## MODULE OVERVIEW

The 6020 Four Channel 20-bit Digital to Analog Converter (DAC) converts two AES digital audio streams to four channels of analog audio. Digital to analog conversion is performed with 20-bit precision.

As shown in the block diagram below, two AES audio inputs from BNCs on the backplane enter the module and pass through AES receiver circuitry to the digital to analog converters. A gain adjustment is provided for the analog output levels. The buffered audio is then fed to the output to a 15-pin high density connector. Unbalanced monitor outputs are provided on BNC connectors.

Status indicators include error detection for noting presence of valid AES input signals as well as indication that emphasis flags have been set on either AES input. Appropriate de-emphasis is applied automatically when a flag is set.

Control of the module can be from one of the remote Avenue options or from the local controls on the front of the module. The gain of the analog output stages can be adjusted remotely or locally. The on-board microprocessor communicates with the frame for remote control via the Avenue System Control module if installed. Module ID information (slot location, software version and board revision) and status information can be monitored by the frame System Control module and read using the optional interfaces available. Alarms can also be enabled if desired.

Power is derived from the  $\pm 12$  volt frame power. It is regulated to the required voltages for the module by on-board regulators. The module is fused with resettable fuse devices. If the fuse opens due to an overcurrent condition, the module will lose power. After pulling the module, the fuse will reset automatically requiring no replacement fuse.

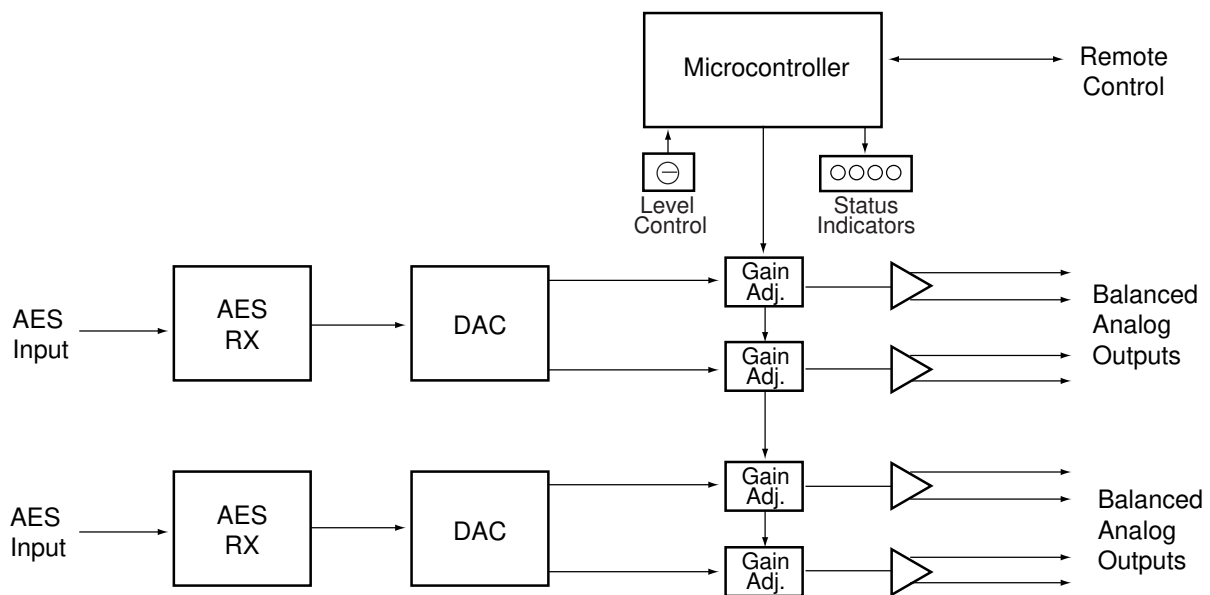

6020 Four Channel 20-bit Audio DAC Functional Block Diagram

## APPLICATIONS

In the application illustrated below, a 6020 module is used to convert two 2-channel AES signals to analog to feed the audio inputs of an analog VTR. Unbalanced monitor outputs are used to drive a local audio monitoring system.

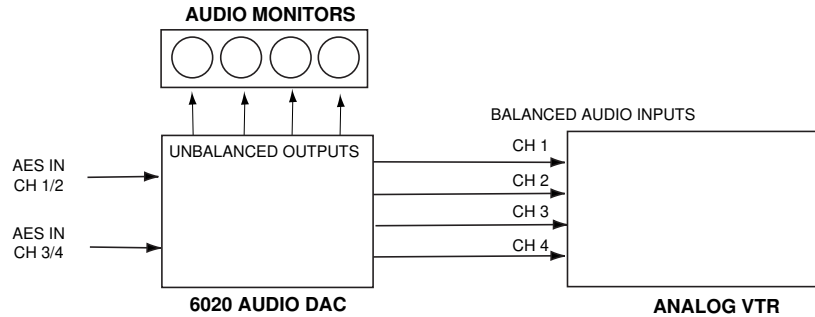

**6020 Feeding an Analog VTR**

Even though it is a four channel device, the 6020 utilizes two separate 2-channel D/A converters. In the application shown below, a 6020 module is used to convert two independent 2-channel AES signals to analog to feed the audio inputs of two independent 2-track analog audio tape recorders. Care should be exercised when connecting the audio outputs of the 6020 to ensure that one machine is connected to outputs 1 and 2 and the other machine to outputs 3 and 4. This will ensure that the pairing of the AES input signals will be preserved at the analog inputs of the two tape machines.

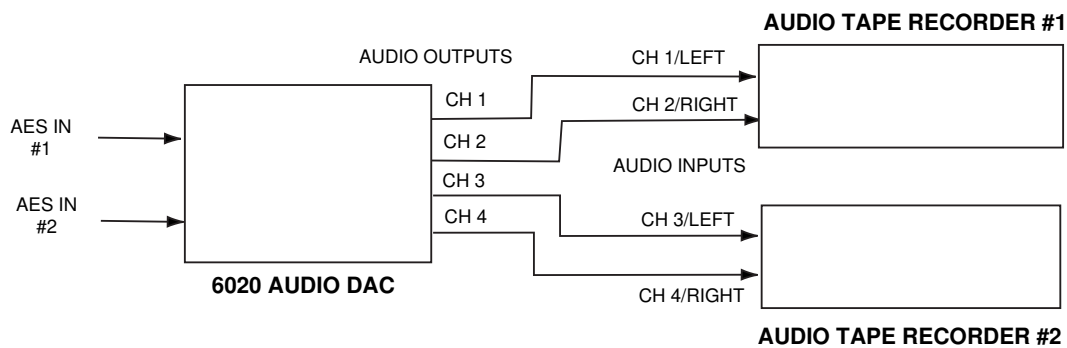

**6030 Converting Two Independent 2-Channel AES Signals**

## Model 6020 Four Channel 20-bit Audio DAC

In the application shown below, a 6020 module is used to convert two AES audio outputs of a digital VTR to analog in order to feed an analog audio routing switcher.

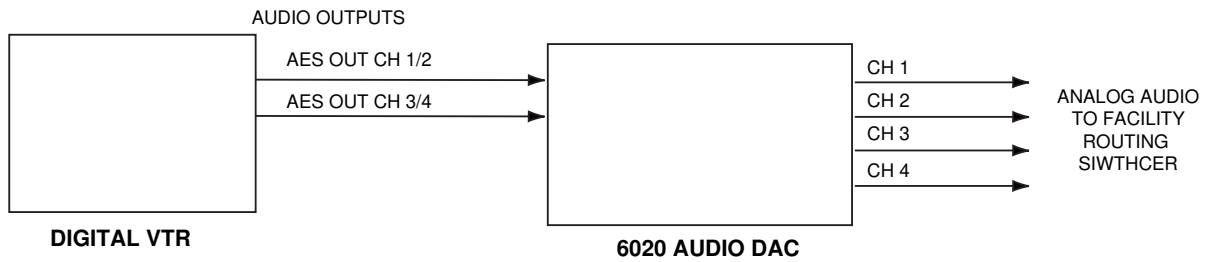

**6020 Converting Digital VTR Outputs to Feed Analog Routing Switcher**

The 6020 has balanced transformerless outputs. This application shows how to drive external equipment with single-ended (unbalanced) inputs. Note that the minus (-) side of the balanced output stage is left floating; it should **not** be connected to ground. In addition to its four balanced line level outputs, the 6020 has four unbalanced outputs. These outputs, available on BNC connectors, are suitable for driving monitor amplifiers or other similar equipment as shown in the first application on the preceding page.

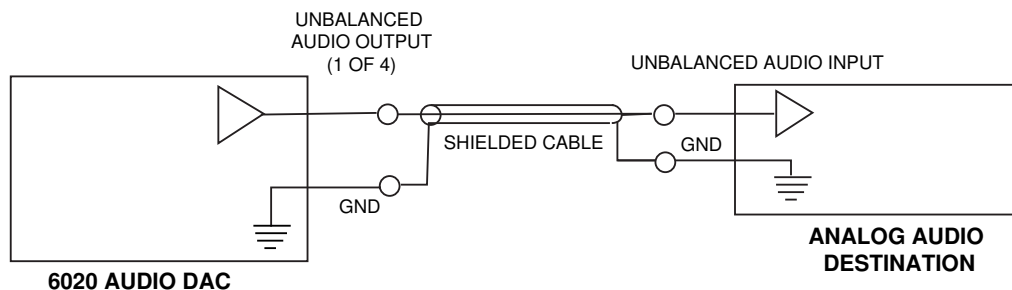
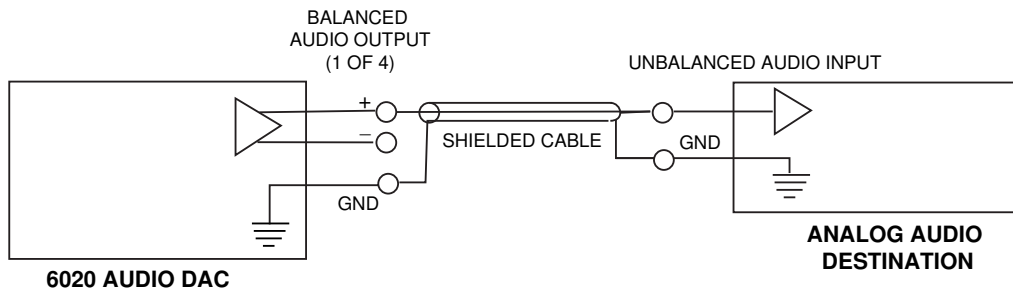

**6020 Driving Single-Ended Inputs**

## INSTALLATION

Plug the 6020 module into any one of the ten slots in the frame and install the plastic overlay provided onto the corresponding group of rear BNC connectors associated with the module location. Note that the plastic overlay has an optional adhesive backing for securing it to the frame. Use of the adhesive backing is only necessary if you would like the location to be permanent and is not recommended if you need to change module locations. This module may be hot-swapped (inserted or removed) without powering down or disturbing performance of the other modules in the system.

## CABLING

Refer to the backplane diagram of the module below for cabling instructions.

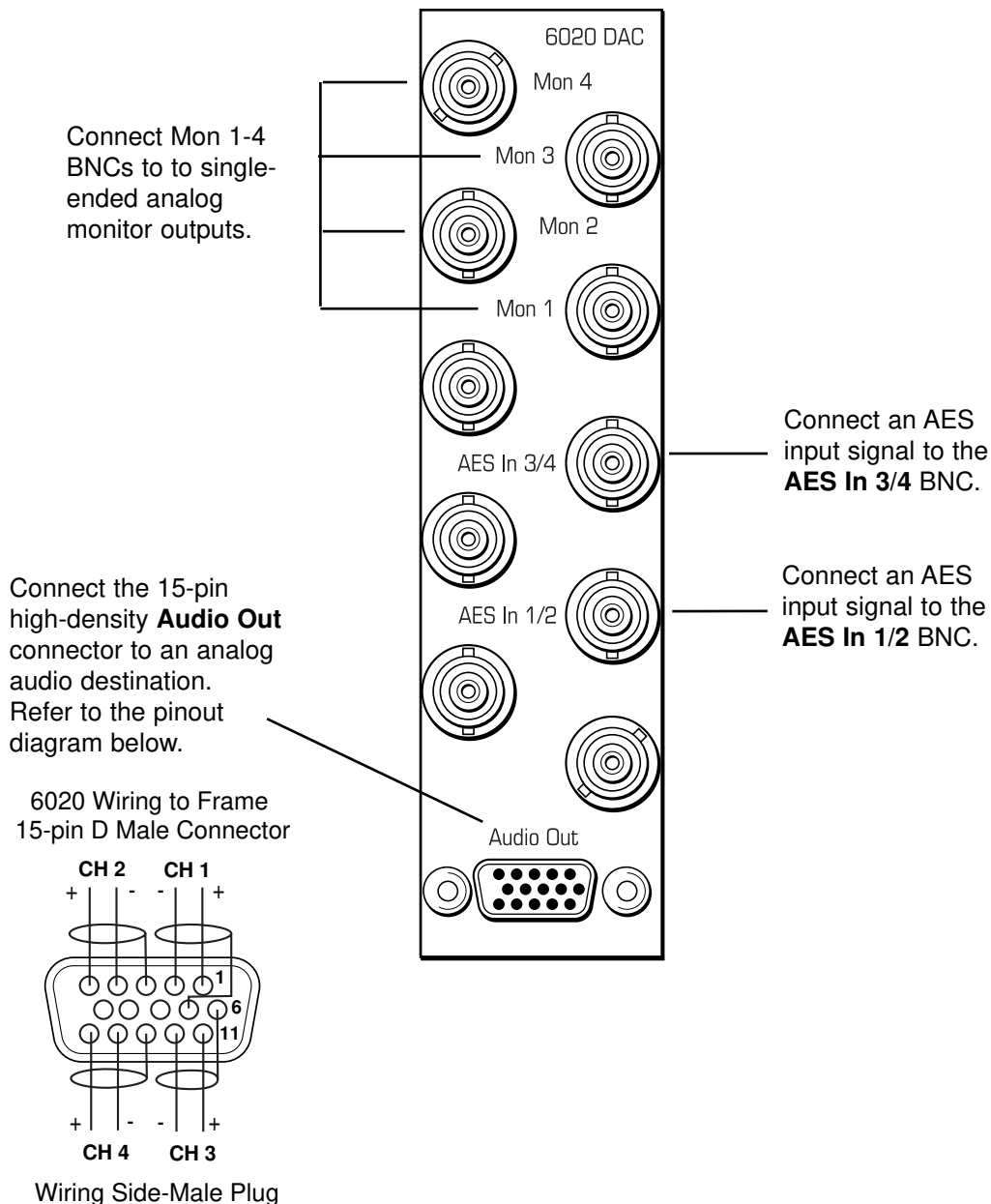

## MODULE CONFIGURATION AND CONTROL

The parameters for each Avenue module must be configured after installation. This can be done remotely using one of the Avenue remote control options or locally using the module front panel controls. Each module has a **REMOTE/LOCAL** switch on the front edge of the circuit board which must first be set to the control mode you will be using.

The configuration parameter choices for the module will differ between **Remote** and **Local** modes. In **Remote** mode, the choices are made through software and allow more selections. The **6020 Parameter Table** on the following page summarizes and compares the various configuration parameters that can be set remotely or locally and the default/factory settings.

If you are not using an remote control option, the module parameters must be configured from the front panel switches. Parameters that have no front panel control will be set to a default value. The **Local** switches are illustrated in the **Front Panel Controls and Indicators** section following the **6020 Parameter Table**.

Avenue module parameters can be configured and controlled remotely from one or both of the remote control options, the Avenue Touch Screen or the Avenue PC Application. Once the module parameters have been set remotely, the information is stored on the module CPU. This allows the module be moved to a different cell in the frame at your discretion without losing the stored information. Remote configuration will override whatever the switch settings are on the front edge of the module.

For setting the parameters remotely using the Avenue PC option, refer to the **Avenue PC Remote Configuration** section of this document.

For setting the parameters remotely using the Avenue Touch Screen option, refer to the **Avenue Touch Screen Remote Configuration** section of this data pack following Avenue PC.

6020 Parameter Table

CONTROL	LOCAL	REMOTE	DEFAULT VALUE
Ch 1/2 Mode Ch 3/4 Mode	No Adjustment	2-Channel Stereo Quad Tracking	Quad Tracking
Ch 1/2 Emph Mode Ch 3/4 Emph Mode	No Adjustment	Off On Auto	Auto
CH 1-4 Digital Ref	No Adjustment	-20 dBFS -18 dBFS -16DBFS (Ch 1-4 Quad Tracking, Ch 1/2 and/or 3/4 stereo pair or individual channel adjustment)	N/A
Ch 1-4 Analog Ref	Shaft Encoder: -10dBu to +8dBu	-10dBu to +8dBu (Ch 1-4 Quad Tracking, Ch 1/2 and/or 3/4 stereo pair or individual channel adjustment)	N/A

## Front Panel Controls and Indicators

Each front edge indicator and switch setting is explained in the diagram below:

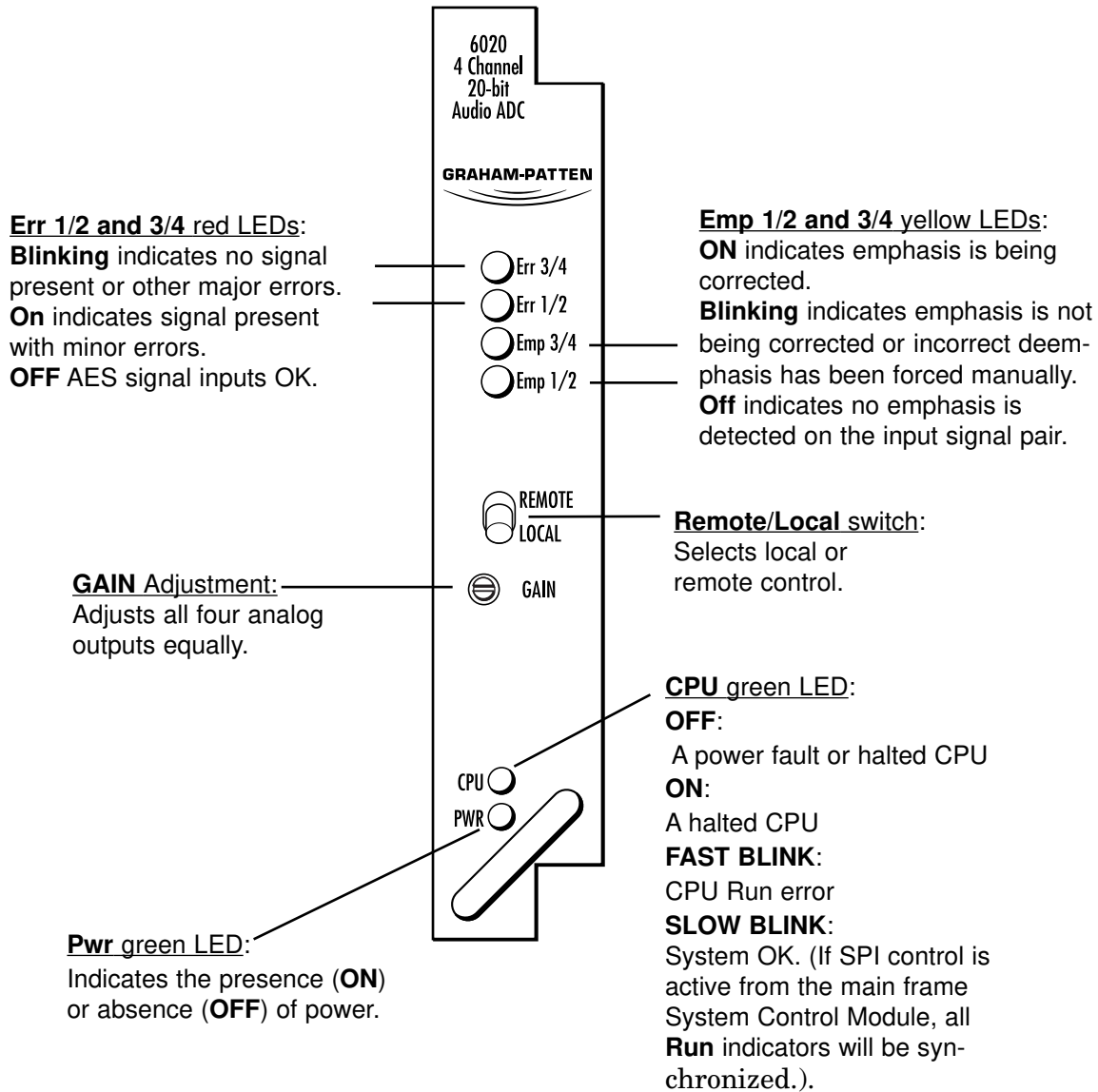

## Avenue PC Remote Configuration

The Avenue PC remote control menus for this module are illustrated and explained in this section. Refer to the **6020 Parameter Table** shown earlier for a summary of available parameters that can be set remotely through the menus illustrated. For more information on using Avenue PC, refer to the Avenue PC Control Application Software data pack that came with the option.

### 6020 Avenue PC Menus

The menus for the 6020 Audio DAC in the Avenue PC application allow you to set the parameters for four channels of audio on this module. You may choose from three operating modes, **2-Channel**, **Stereo** or **Quad Tracking**.

You may set all four channels to **2-Channel** mode, where each of the four audio channels will be independent of each other. Adjustments may be made to each channel individually and will not affect the other channels. Menu selections are provided for each channel as shown in the following section.

You may set the four channels to **Stereo** mode, where Channels 1 and 2 and Channels 3 and 4 are stereo pairs. Adjustments made in the menus to one channel in the pair will change the other channel. Channel 1 and 2 can be set to be independent (**2-Channel**) while Channel 3 and 4 can be set to be a stereo pair if desired (or vice versa).

All four channels can be set to **Quad Tracking** where all channels will track together. If parameters are changed in one channel, the other channels will track the change. Selecting **Quad Tracking** in any one of the menus will change all channels to quad tracking mode. A **Quad Menu** has been provided to allow easier adjusting and monitoring of all four channels together.

In the **Ch 1/2 Menu** shown below, set the following parameters:

- **Ch 1/2 Mode** - set the operating modes for Channels 1 and 2. Choose from **2-Channel** (Ch 1 and 2 will be independent), **Stereo** (Ch 1/2 will be a stereo pair) or **Quad Tracking** (Ch 1-4 will track together.) Note that if you have set Ch 3/4 in the next menu to **Quad Tracking** or the **Quad On** function is enabled on the **Quad Menu**, this selection will default to **Quad Tracking**.
- **Ch 1 Digital Ref** - set the Digital Audio Reference level to match the studio reference (-20dBFS, -18dBFS or -16dBFS) for channel 1 (in **2-Channel** mode), Ch 1/2 if in **Stereo** mode or all four channels together if in **Quad Tracking** mode.
- **Ch 1 Analog Ref** - use slider to set the Analog Audio Reference level from -10dBu to +8dBu (in 0.5dBu steps) for channel 1 only (in **2-Channel** mode), Ch 1/2 if in **Stereo** mode or all four channels if in **Quad Tracking** mode.
- **Ch 2 Dig Ref** - when **Ch 1/2 Mode** is set to **2-Channel**, this will adjust Channel 2 Digital Reference level only. If **Ch 1/2 Mode** is set to **Stereo**, adjustment will affect the stereo pair, or if set to **Quad Tracking**, adjustment will affect all channels.
- **Ch 2 Analog Ref** - when **Ch 1/2 Mode** is set to **2-Channel**, this slider will adjust Channel 2 Analog Reference level only. If **Ch 1/2 Mode** is set to **Stereo**, adjustment will affect the stereo pair, or if set to **Quad Tracking**, adjustment will affect all channels.
- **Ch 1/2 Emph** - sets the emphasis correction mode for these two channels. **Off** disables the emphasis correction. **On** applies 50/15µS deemphasis to the two channels when the sampling frequency is standard. (Note that deemphasis will not be applied where frequencies are non-standard.) **Auto** applies 50/15µS deemphasis as necessary depending on the AES input emphasis status and sampling frequency. (Note that deemphasis will not be applied when the channel status indicates the use of CCITT J.17 emphasis.)

In this menu, the following indicators are available:

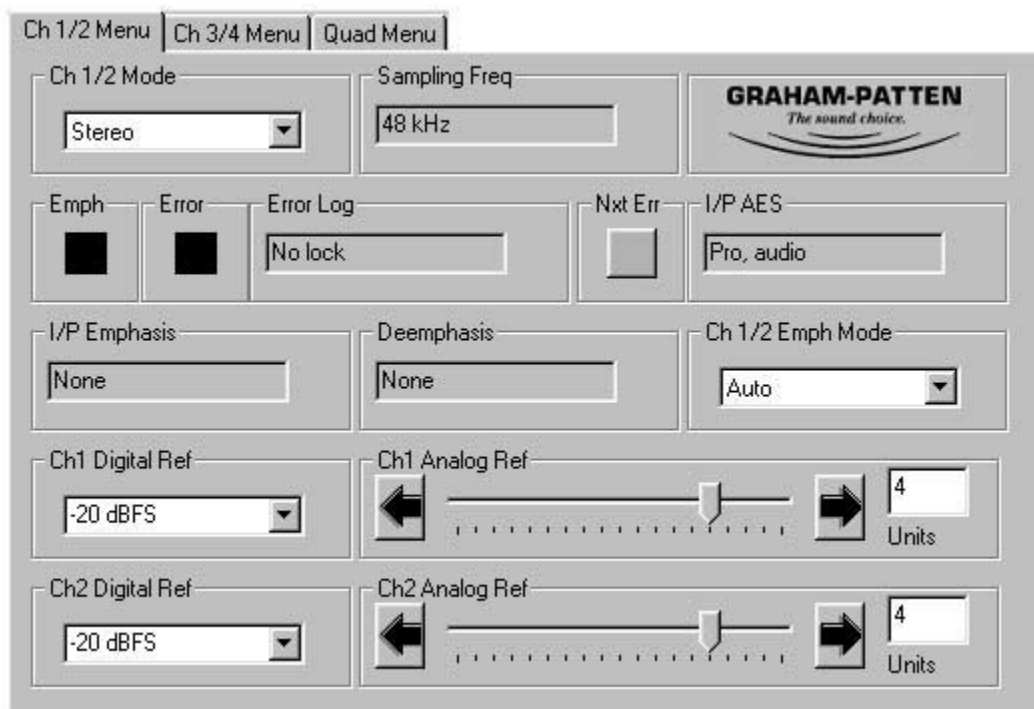

- **Emph** - the color of this box indicates the status of emphasis on the digital input signal pair as follows:
  - Yellow** indicates emphasis is present on the input and is being corrected.
  - Yellow/Gray (blink)** indicates input emphasis is not being corrected or incorrect deemphasis has been forced manually.
  - Black** indicates no emphasis is detected on the input signal pair.
- **Error** - will indicate the presence of errors on the input signal pair as follows:
  - Red** indicates minor errors exist on the input signal pair and have been logged.
  - Red/Gray (Blink)** indicates major errors exist on the input signal pair and have been logged.
  - Black** indicates no errors exist on the input signal pair.
- **Nxt Err** - a left mouse-click on this box will clear the currently displayed error in the **Error Log** (explained below). It will then display the next highest priority error logged if it is present.
- **Sampling Freq** - displays the sampling frequency of the input signal pair. The following sampling frequencies will be displayed:
  - 48kHz**
  - 44.1kHz**
  - 44.056kHz**
  - 32kHz**
  - Non-standard** indicates the sampling frequency is not within 4% of any of the above frequencies.
- **Error Log** - displays the most important error detected in the AES input signal pair that occurred since the log was last cleared. Seven error messages, in order of decreasing importance, may be displayed as follows. The first three of these are treated as major errors.
  - No lock - input PLL is unable to lock to the AES input signal.
  - Bi-phase coding - a bi-phase coding error in the AES input signal is detected.
  - Parity - a parity error has been detected.
  - CRC - the CRC data in the AES input signal did not match the locally calculated CRC (professional format only).
  - Confidence - the input signal eye opening has fallen below AES standard limits.
  - Invalid Error - the validity bit in the AES input signal has been set.
  - No error - no errors have been detected since the log was last cleared.

- **I/P AES** - displays information about the input AES signal that is decoded from the channel status information as follows:
  - Blank - Professional format with CRC errors.
  - Pro Audio - Professional format where stream contains audio data.
  - Pro non-audio - Professional format where stream contains non-audio data.
  - Cons audio - Consumer format where stream contains non-copyright audio data.
  - Cons non-audio - Consumer format where stream contains non-audio data.
  - Cons copy OK - Consumer format where stream contains original copyright material that may be copied once.
  - Cons copy inh - Consumer format where stream contains a copy of copyright material that may not be copied again.
- **I/P Emphasis** - displays emphasis data decoded for the input AES signal as follows:
  - None - indicates input signal has no emphasis.
  - Not indicated - emphasis status of the AES input audio is not indicated (professional format only).
  - 50/15 $\mu$ S - emphasis using these time constants was applied to the input AES signal.
  - CCITT J.17 - emphasis conforming to this standard was applied to the input AES signal (professional format only).
- **Deemphasis** - displays any deemphasis being applied to the signal by the 6020 module as follows:
  - None - no deemphasis is being applied.
  - 50/15 $\mu$ S - deemphasis using these time constants is being applied.

In the **Ch 3/4 Menu** shown below, set the following parameters:

- **Ch 3/4 Mode** - set the operating modes for Channels 3 and 4. Choose from **2-Channel** (Ch 3 and 4 will be independent), **Stereo** (Ch 3/4 will be a stereo pair) or **Quad Tracking** (Ch 1-4 will track together). Note that if you have set Ch 1/2 to **Quad Tracking** or the **Quad On** function is enabled on the **Quad Menu**, this selection will default to **Quad Tracking**.
- **Ch 3 Digital Ref** - sets the Digital Audio Reference level for channel 3 (in **2-Channel** mode). If **Ch 3/4 Mode** is set to **Stereo**, adjustment will affect the stereo pair, or if set to **Quad Tracking**, adjustment will affect all channels.
- **Ch 3 Analog Ref** - sets the Analog Audio Reference level from -10dBu to +8dBu (in 0.5dBu steps) for channel 3 only (in **2-Channel** mode). If **Ch 3/4 Mode** is set to **Stereo**, adjustment will affect the stereo pair, or if set to **Quad Tracking**, adjustment will affect all channels.
- **Ch 4 Dig Ref** - When **Ch 3/4 Mode** is set to **2-Channel**, this will adjust Channel 4 Digital Reference level only. If **Ch 3/4 Mode** is set to **Stereo**, adjustment will affect the stereo pair, or if set to **Quad Tracking**, adjustment will affect all channels.
- **Ch 4 Analog Ref** - When **Ch 3/4 Mode** is set to **2-Channel**, this will adjust Channel 4 Analog Reference level only. If **Ch 3/4 Mode** is set to **Stereo**, adjustment will affect the stereo pair, or if set to **Quad Tracking**, adjustment will affect all channels.
- **Ch 3/4 Emph** - sets the emphasis correction mode for these two channels. **Off** disables the emphasis correction. **On** applies 50/15µS deemphasis to the two channels when the sampling frequency is standard. (Note that deemphasis will not be applied where frequencies are non-standard.) **Auto** applies 50/15µS deemphasis as necessary depending on the AES input emphasis status and sampling frequency. (Note that deemphasis will not be applied when the channel status indicates the use of CCITT J.17 emphasis.)

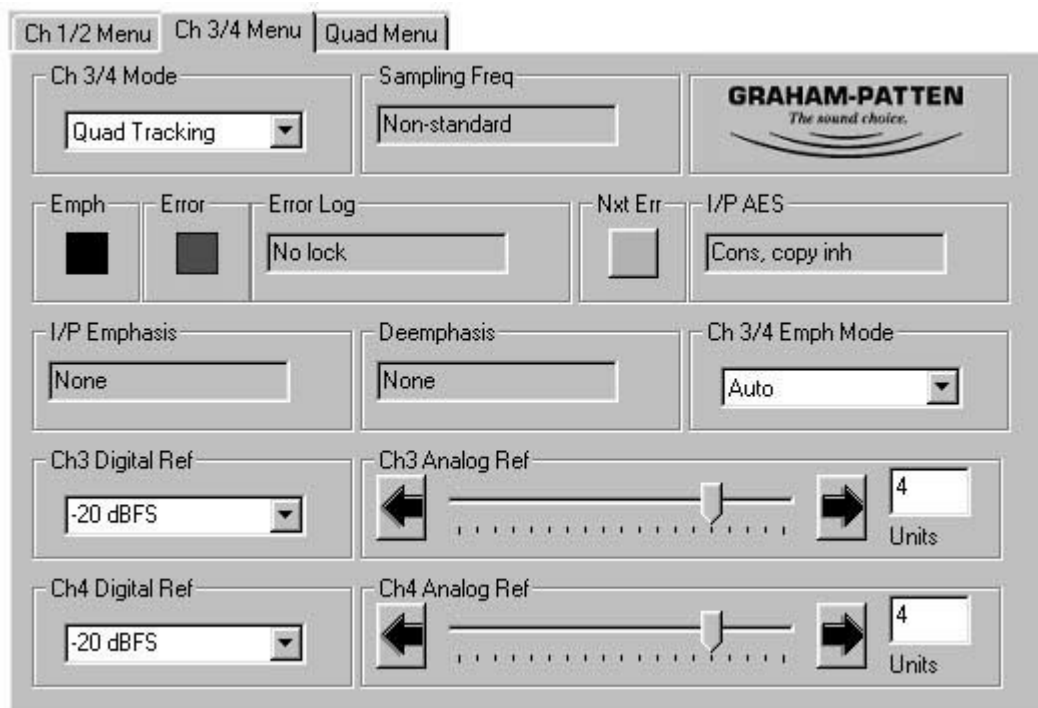

Refer to the **Emph**, **Error**, **Nxt Error**, **Sampling Freq**, **Error Log**, **I/P AES**, **I/P Emphasis**, and **Deemphasis** indicator explanations for the **Ch1/2** menu shown earlier.

The **Quad Menu** shown below has been provided to allow adjusting and monitoring all four channels at the same time when in **Quad Tracking** mode. Set the parameters as follows:

- **Channel Mode** - Click in the **Quad On** box to enable quad tracking simultaneously for all four channels. Note that **Quad Tracking** can also be enabled in any of the previous **Channel Mode** menus.
- **Emphasis Mode** - set the emphasis mode for all four channels.
- **Digital Ref** - set all four channels for the Digital Reference level to match your studio reference.
- **Analog Ref** - adjust the Analog Reference level of all four channels to -10dBu to +8dBu (in 0.5dBu steps).

**NOTE:** Digital and Analog Ref settings and Emphasis Mode above will only be active when **Quad On** is checked.

The following indicators are available in the menu below:

- **Err 1/2 and Err 3/4** - indicates the presence of errors on the input signal pairs as described previously in the **Ch 1/2 Menu** indicator descriptions.
- **Emph** (2 boxes) - each box shows the status of emphasis for the channel pair corresponding to the **Error** box above it.

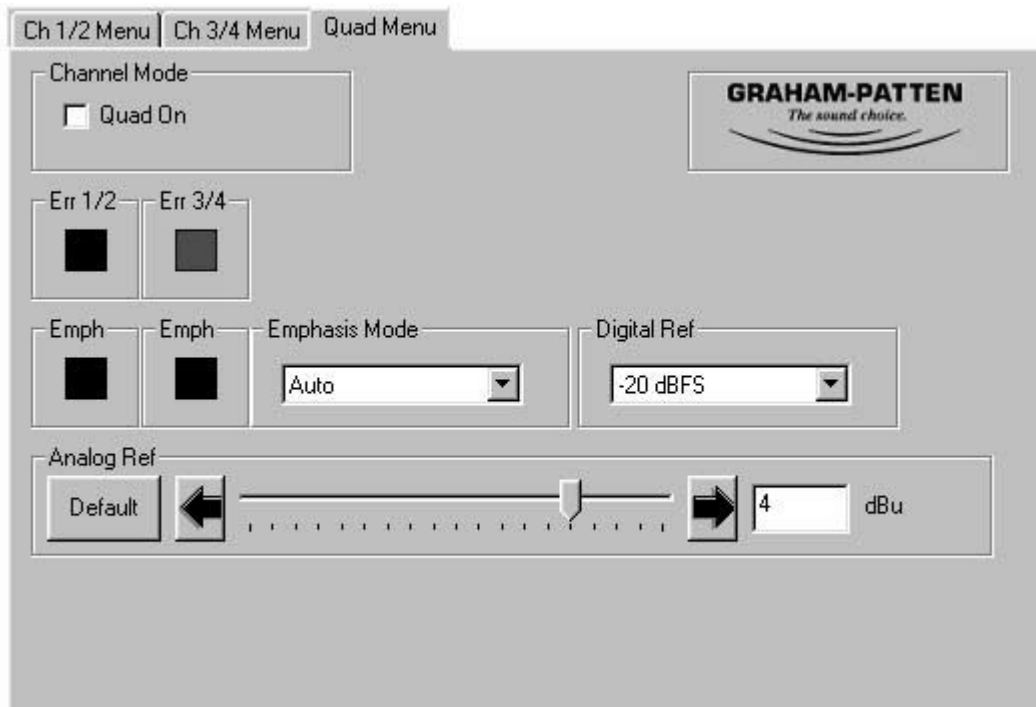

## Avenue Touch Screen Remote Configuration

Avenue Touch Screen remote control menus for this module are illustrated and explained below. Refer to the **6020 Parameter Table** shown earlier for a summary of available parameters that can be set remotely through the menus illustrated. For more information on using Avenue Touch Screen, refer to the Avenue Touch Screen data pack that came with the option.

### 6020 Avenue Touch Screen Menus

In the **Ch 1 Menu** shown below, set the following parameters:

- **Ch 1/2 Mode** - set the operating modes for Channels 1 and 2. Choose from **2-Channel** (Ch 1 and 2 will be independent), **Stereo** (Ch 1/2 will be a stereo pair) or **Quad Tracking** (Ch 1-4 will track together.) Note that if you have set Ch 3/4 to **Quad Tracking** or the **Quad On** function is enabled on the **Quad Menu**, this selection will default to **Quad Tracking**.
- **Ch 1 Digital Ref** - set the Digital Audio Reference level to match the studio reference (-20dBFS, -18dBFS or -16dBFS) for channel 1 (in **2-Channel** mode), Ch 1/2 if in **Stereo** mode or all four channels together if in **Quad Tracking** mode.
- **Ch 1 Analog Ref** - use slider to set the Analog Audio Reference level from -10dBu to +8dBu (in 0.5dBu steps) for channel 1 only (in **2-Channel** mode), Ch 1/2 if in **Stereo** mode or all four channels if in **Quad Tracking** mode.
- **Ch 1/2 Emph** - sets the emphasis correction mode for these two channels. **Off** disables the emphasis correction. **On** applies 50/15 $\mu$ S deemphasis to the two channels when the sampling frequency is standard. (Note that deemphasis will not be applied where frequencies are non-standard.) **Auto** applies 50/15 $\mu$ S deemphasis as necessary depending on the AES input emphasis status and sampling frequency. (Note that deemphasis will not be applied when the channel status indicates the use of CCITT J.17 emphasis.)

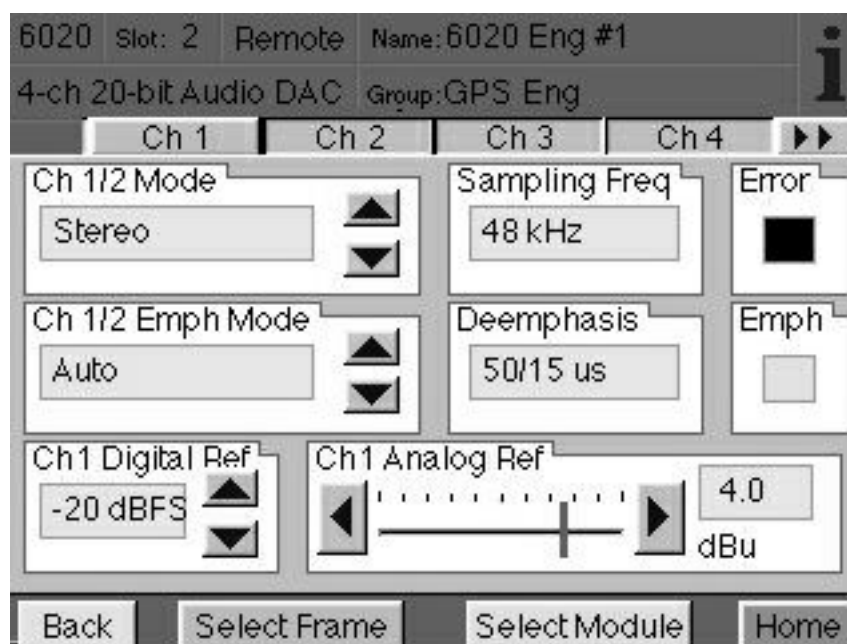

The following indicators are available in Channel 1-4 menus:

- **Sampling Freq** - displays the sampling frequency of the input signal pair. The following sampling frequencies will be displayed:
  - 48kHz**
  - 44.1kHz**
  - 44.056kHz**
  - 32kHz****Non-standard** indicates the sampling frequency is not within 4% of any of the above frequencies.
- **Deemphasis** - displays any deemphasis being applied to the signal by the 6020 module as follows:
  - None - no deemphasis is being applied.
  - 50/15µS - deemphasis using these time constants is being applied.
- **Error** - will indicate the presence of errors on the input signal pair as follows:
  - Red** indicates minor errors exist on the input signal pair and have been logged.
  - Red/Gray (Blink)** indicates major errors exist on the input signal pair and have been logged.
  - Black** indicates no errors exist on the input signal pair.
- **Emph** - the color of this box indicates the status of emphasis on the digital input signal pair as follows:
  - Yellow** indicates emphasis is present on the input and is being corrected.
  - Yellow/Gray (blink)** indicates input emphasis is not being corrected or incorrect deemphasis has been forced manually.
  - Black** indicates no emphasis is detected on the input signal pair.

Refer to the **Ch 1/2** and **Ch 3/4 Status** menus later in this section for more status indicators and error logs.

In the **Ch 2 Menu** shown below, set the following parameters:

- **Ch 1/2 Mode** - set the operating modes for Channels 1 and 2. Choose from **2-Channel** (Ch 1 and 2 will be independent), **Stereo** (Ch 1/2 will be a stereo pair) or **Quad Tracking** (Ch 1-4 will track together.) Note that if you have set Ch 3/4 to **Quad Tracking** or the **Quad On** function is enabled on the **Quad Menu**, this selection will default to **Quad Tracking**.
- **Ch 2 Dig Ref** - when **Ch 1/2 Mode** is set to **2-Channel**, this will adjust Channel 2 Digital Reference level only. If **Ch 1/2 Mode** is set to **Stereo**, adjustment will affect the stereo pair, or if set to **Quad Tracking**, adjustment will affect all channels.
- **Ch 2 Analog Ref** - when **Ch 1/2 Mode** is set to **2-Channel**, this slider will adjust Channel 2 Analog Reference level only. If **Ch 1/2 Mode** is set to **Stereo**, adjustment will affect the stereo pair, or if set to **Quad Tracking**, adjustment will affect all channels.
- **Ch 1/2 Emph** - sets the emphasis correction mode for these two channels. **Off** disables the emphasis correction. **On** applies 50/15µS deemphasis to the two channels when the sampling frequency is standard. (Note that deemphasis will not be applied where frequencies are non-standard.) **Auto** applies 50/15µS deemphasis as necessary depending on the AES input emphasis status and sampling frequency. (Note that deemphasis will not be applied when the channel status indicates the use of CCITT J.17 emphasis.)

Refer to the description of the **Sampling Frequency**, **Deemphasis**, **Error** and **Emph** indicators in the previous **Channel 1** section.

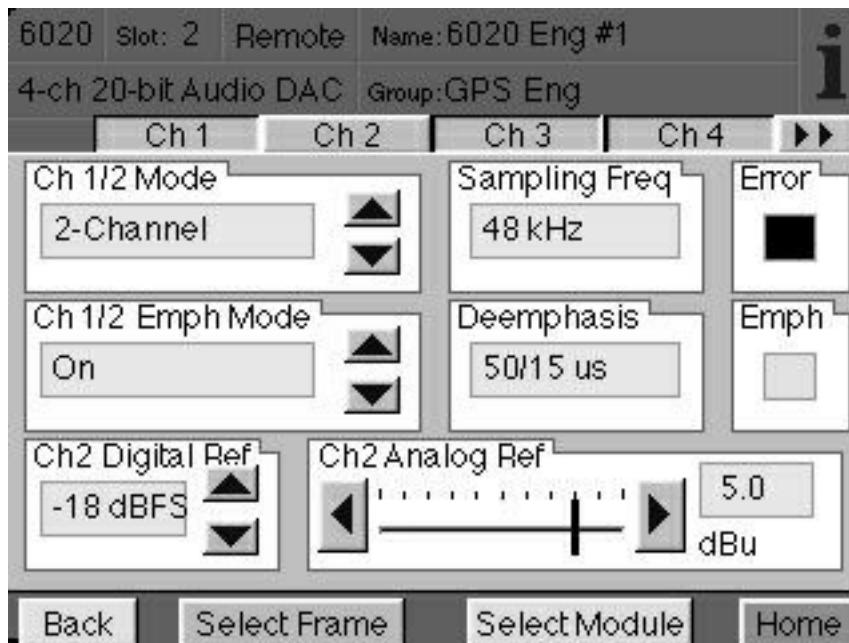

In the **Ch 3 Menu** shown below, set the following parameters:

- **Ch 3/4 Mode** - set the operating modes for Channels 3 and 4. Choose from **2-Channel** (Ch 3 and 4 will be independent), **Stereo** (Ch 3/4 will be a stereo pair) or **Quad Tracking** (Ch 1-4 will track together.) Note that if you have set Ch 1/2 to **Quad Tracking** or the **Quad On** function is enabled on the **Quad Menu**, this selection will default to **Quad Tracking**.
- **Ch 3 Digital Ref** - sets the Digital Audio Reference level for channel 3 (in **2-Channel** mode). If **Ch 3/4 Mode** is set to **Stereo**, adjustment will affect the stereo pair, or if set to **Quad Tracking**, adjustment will affect all channels.
- **Ch 3 Analog Ref** - sets the Analog Audio Reference level from -10dBu to +8dBu (in 0.5dBu steps) for channel 3 only (in **2-Channel** mode). If **Ch 3/4 Mode** is set to **Stereo**, adjustment will affect the stereo pair, or if set to **Quad Tracking**, adjustment will affect all channels.
- **Ch 3/4 Emph** - sets the emphasis correction mode for these two channels. **Off** disables the emphasis correction. **On** applies 50/15µs deemphasis to the two channels when the sampling frequency is standard. (Note that deemphasis will not be applied where frequencies are non-standard.) **Auto** applies 50/15µs deemphasis as necessary depending on the AES input emphasis status and sampling frequency. (Note that deemphasis will not be applied when the channel status indicates the use of CCITT J.17 emphasis.)

Refer to the description of the **Sampling Frequency**, **Deemphasis**, **Error** and **Emph** indicators in the previous **Channel 1** section.

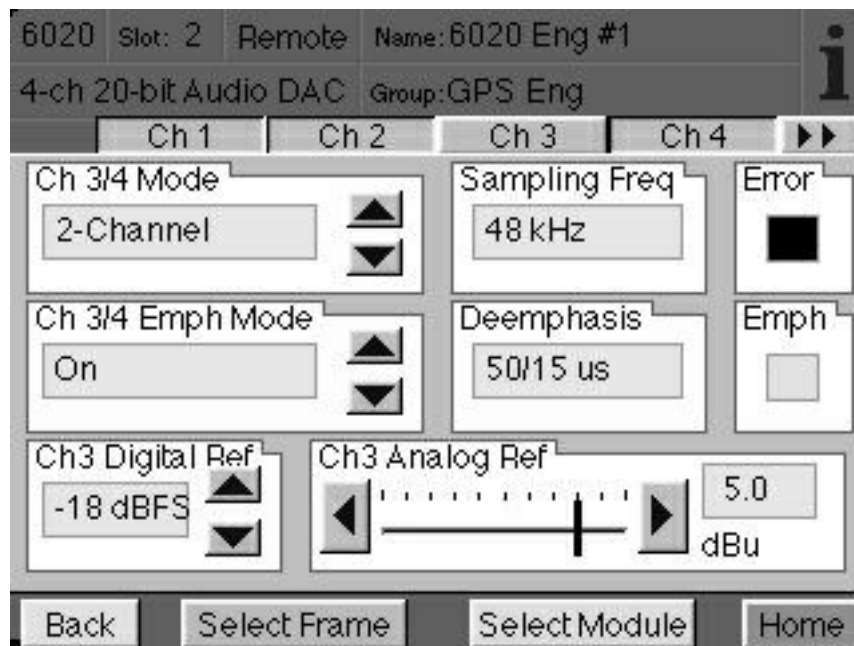

In the **Ch 4 Menu** shown below, set the following parameters:

- **Ch 3/4 Mode** - set the operating modes for Channels 3 and 4. Choose from **2-Channel** (Ch 3 and 4 will be independent), **Stereo** (Ch 3/4 will be a stereo pair) or **Quad Tracking** (Ch 1-4 will track together.) Note that if you have set Ch 1/2 to **Quad Tracking** or the **Quad On** function is enabled on the **Quad Menu**, this selection will default to **Quad Tracking**.
- **Ch 4 Dig Ref** - When **Ch 3/4 Mode** is set to **2-Channel**, this will adjust Channel 4 Digital Reference level only. If **Ch 3/4 Mode** is set to **Stereo**, adjustment will affect the stereo pair, or if set to **Quad Tracking**, adjustment will affect all channels.
- **Ch 4 Analog Ref** - When **Ch 3/4 Mode** is set to **2-Channel**, this will adjust Channel 4 Analog Reference level only. If **Ch 3/4 Mode** is set to **Stereo**, adjustment will affect the stereo pair, or if set to **Quad Tracking**, adjustment will affect all channels.
- **Ch 3/4 Emph** - sets the emphasis correction mode for these two channels. **Off** disables the emphasis correction. **On** applies 50/15 $\mu$ S deemphasis to the two channels when the sampling frequency is standard. (Note that deemphasis will not be applied where frequencies are non-standard.) **Auto** applies 50/15 $\mu$ S deemphasis as necessary depending on the AES input emphasis status and sampling frequency. (Note that deemphasis will not be applied when the channel status indicates the use of CCITT J.17 emphasis.)

Refer to the description of the **Sampling Frequency**, **Deemphasis**, **Error** and **Emph** indicators in the previous **Channel 1** section.

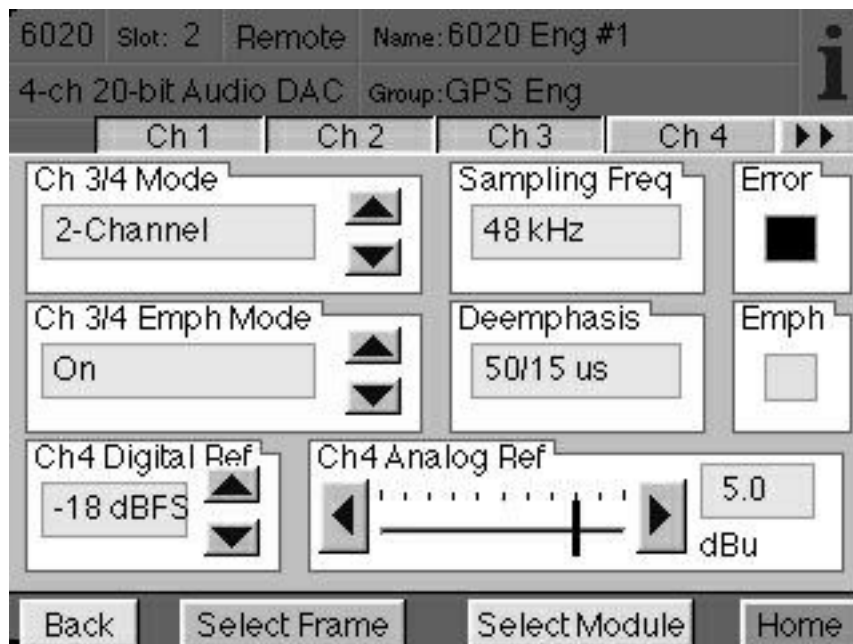

## Model 6020 Four Channel 20-bit Audio DAC

The **Quad Menu** shown below has been provided to allow adjusting and monitoring all four channels at the same time when in **Quad Tracking** mode. Set the parameters as follows:

- **Channel Mode** - Click in the **Quad On** box to enable quad tracking simultaneously for all four channels. Note that **Quad Tracking** can also be enabled in any of the previous **Channel Mode** menus.
- **Emphasis Mode** - set the emphasis mode for all four channels.
- **Digital Ref** - set all four channels for the Digital Reference level to match your studio reference.
- **Analog Ref** - adjust the Analog Reference level of all four channels to -10dBu to +8dBu (in 0.5dBu steps).

**NOTE:** Digital and Analog Ref settings and Emphasis Mode above will only be active when **Quad On** is checked.

The following indicators are available in the menu below:

- **Err 1/2 and Err 3/4** - indicates the presence of errors on the input signal pairs as described previously in the **Ch 1/2 Menu** indicator descriptions.
- **Emph** (2 boxes) - each box shows the status of emphasis for the channel pair corresponding to the **Error** box above it.

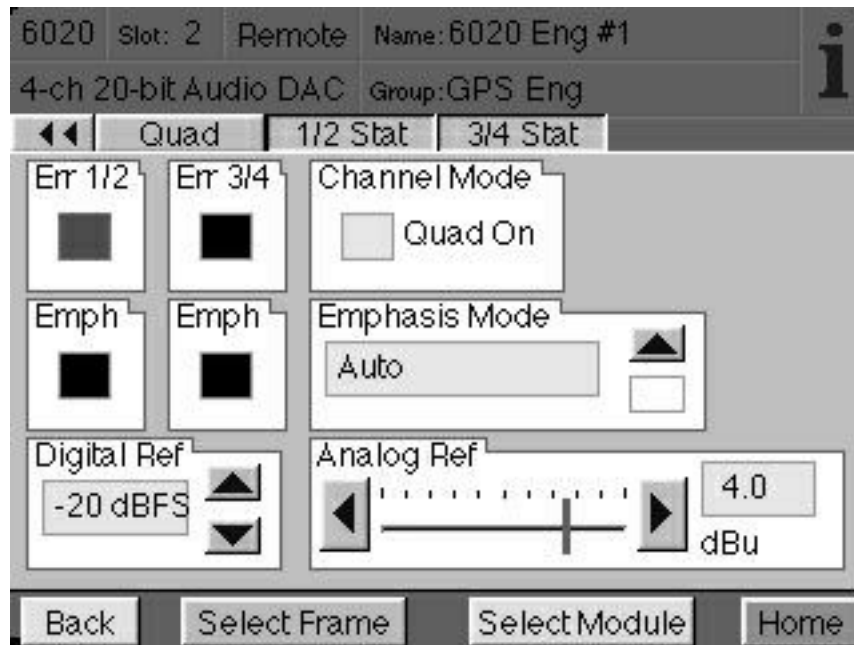

In the **1/2 Stat Menu** shown below, the following indicators and error logs are available for Channels 1 and 2:

- I/P AES** - displays information about the input AES signal that is decoded from the channel status information as follows:
  - Blank - Professional format with CRC errors.
  - Pro Audio - Professional format where stream contains audio data.
  - Pro non-audio - Professional format where stream contains non-audio data.
  - Cons audio - Consumer format where stream contains non-copyright audio data.
  - Cons non-audio - Consumer format where stream contains non-audio data.
  - Cons copy OK - Consumer format where stream contains original copyright material that may be copied once.
  - Cons copy inh - Consumer format where stream contains a copy of copyright material that may not be copied again.
- Sampling Freq** - displays the sampling frequency of the input signal pair. The following sampling frequencies will be displayed:
  - 48kHz**
  - 44.1kHz**
  - 44.056kHz**
  - 32kHz**
  - Non-standard** indicates the sampling frequency is not within 4% of any of the above frequencies.
- Error** - will indicate the presence of errors on the input signal pair as follows:
  - Red** indicates minor errors exist on the input signal pair and have been logged.
  - Red/Gray (Blink)** indicates major errors exist on the input signal pair and have been logged.
  - Black** indicates no errors exist on the input signal pair.

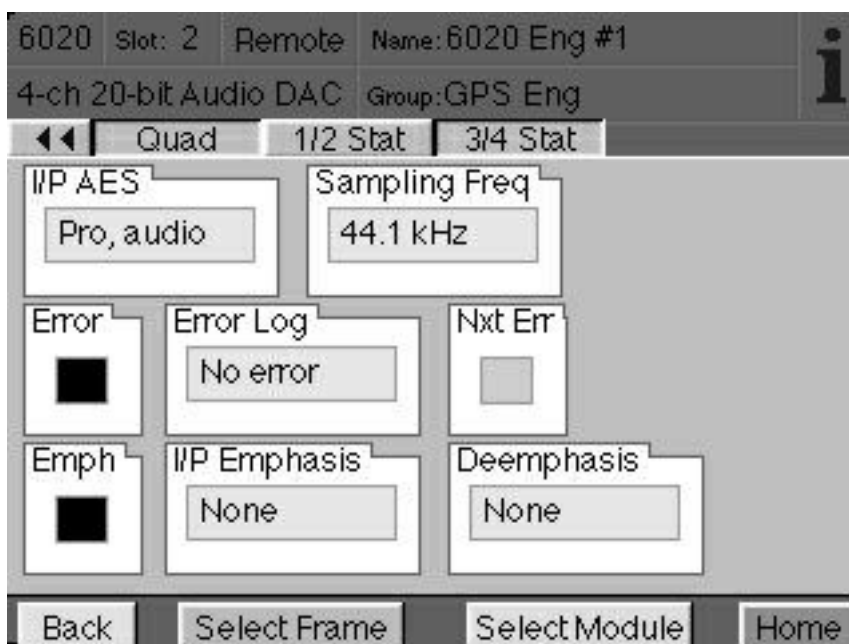

- **Emph** - the color of this box indicates the status of emphasis on the digital input signal pair as follows:
  - Yellow** indicates emphasis is present on the input and is being corrected.
  - Yellow/Gray (blink)** indicates input emphasis is not being corrected or incorrect deemphasis has been forced manually.
  - Black** indicates no emphasis is detected on the input signal pair.
- **I/P Emphasis** - displays emphasis data decoded for the input AES signal as follows:
  - None - indicates input signal has no emphasis.
  - Not indicated - emphasis status of the AES input audio is not indicated (professional format only).
  - 50/15 $\mu$ S - emphasis using these time constants was applied to the input AES signal.
  - CCITT J.17 - emphasis conforming to this standard was applied to the input AES signal (professional format only).
- **Deemphasis** - displays any deemphasis being applied to the signal by the 6020 module as follows:
  - None - no deemphasis is being applied.
  - 50/15 $\mu$ S - deemphasis using these time constants is being applied.
- **Nxt Err** - a left mouse-click on this box will clear the currently displayed error in the **Error Log** (explained below). It will then display the next highest priority error logged if it is present.
- **Error Log** - displays the most important error detected in the AES input signal pair that occurred since the log was last cleared. Seven error messages, in order of decreasing importance, may be displayed as follows. The first three of these are treated as major errors.
  - No lock - input PLL is unable to lock to the AES input signal.
  - Bi-phase coding - a bi-phase coding error in the AES input signal is detected.
  - Parity - a parity error has been detected.
  - CRC - the CRC data in the AES input signal did not match the locally calculated CRC (professional format only).
  - Confidence - the input signal eye opening has fallen below AES standard limits.
  - Invalid Error - the validity bit in the AES input signal has been set.
  - No error - no errors have been detected since the log was last cleared.

In the **3/4 Stat Menu** shown below, the indicators and error logs described for Channel 1 and 2 are also available for Channels 3 and 4. Refer to the previous section for an explanation of each function.

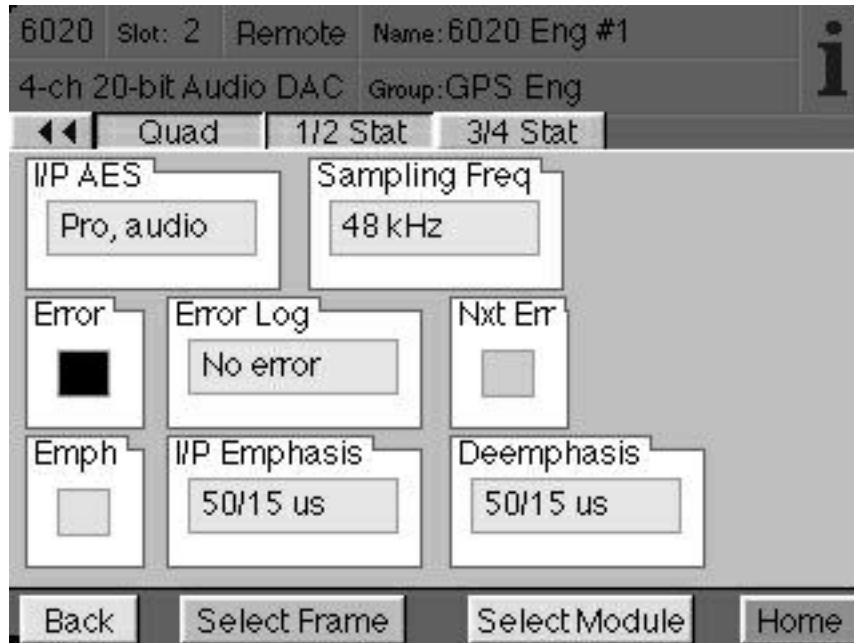

## TROUBLESHOOTING

To aid in troubleshooting, signal reference levels and presence, power and CPU status can be easily monitored from the front panel of this module using the indicators explained in the previous section.

If using the **Remote** mode, the following status items can be monitored using the Avenue Touch Screen Control Panel or PC Application:

- AES input errors
- Emphasis flag set on AES input(s)
- AES input format and content
- Power status
- Slot ID, Software Version and Board Revision

Refer to the overall troubleshooting tips given below for the **6020** module:

### **No status lights are lit on front panel:**

- Check that frame power is present (green LED{s} on frame power supplies).
- Check that module is firmly seated in frame. Try removing it and plugging it in again.

### **Can't control module:**

- Check status of CPU **Run** red LED. Should be blinking slowly and in unison with other modules if System Control module is present. If not, try removing it and plugging it in again.
- System Control module may not be working properly if installed.

### **No analog signal out of module:**

- Check cabling to input of module.
- Check for valid AES signal input.

You may also refer to the technical support section of the Ensemble or Graham-Patten web sites for the latest information on your equipment at the URLs below:

<http://www.ensembledesigns.com/support>

<http://www.gpsys.com>

## SOFTWARE UPDATING

Software upgrades for each module can be downloaded remotely if the optional System Control module is installed. These can be downloaded onto your PC and then Avenue PC will distribute the update to the individual module. (Refer to the Avenue PC documentation for more information) Periodically, updates will be posted on our web site. If you do not have the required System Control Module and Avenue PC, modules can be sent back to the factory for software upgrades.

## **WARRANTY AND FACTORY SERVICE**

### **Warranty**

This Module is covered by a five year limited warranty, as stated in the main Preface of this manual. If you require service (under warranty or not), please contact Ensemble Designs or Graham-Patten Systems and ask for customer service before you return the unit. This will allow the service technician to provide any other suggestions for identifying the problem and recommend possible solutions.

### **Factory Service**

If you return equipment for repair, please get a Return Material Authorization Number (RMA) from the factory first.

Ship the product and a written description of the problem to:

Ensemble Designs, Inc.

Attention: Customer Service RMA #####

870 Gold Flat Rd.

Nevada City, CA. 95959 USA

(530) 478-1830

Fax: (530) 478-1832

service@endes.com

<http://www.ensembledesigns.com>

Be sure to put your RMA number on the outside of the box.

### **OR**

Graham-Patten Systems, Inc.

13366 Grass Valley Avenue

Grass Valley, CA 95945

(800) 422-6662 or (530) 273-8412

Fax: (530) 273-7458

service@gpsys.com

<http://www.gpsys.com>

## SPECIFICATIONS

### 6020 Four Channel 20-bit Audio DAC

AES Inputs: 1 volt p-p, terminated in 75 ohms  
Sample Rate: 30kHz - 50kHz

#### **Balanced Outputs:**

Output Level: Adjustable from -10dBu to +8dBu for -20, -18 or -16dBFS input  
Max Output Level: +24dBu (bridging load), +22dBu (600 ohm load)  
Analog Output Z: 30 ohms

#### **Unbalanced Outputs:**

Output Level: -12dB relative to balanced output  
Max Output Level: +12dBu (bridging load)  
Analog Output Z: 1k ohms

Frequency Response: +0/-0.2dB, 20Hz - 20kHz  
Crosstalk: <-84dB, 20Hz - 20kHz  
Dynamic range: 95dB

Due to ongoing product development, all specifications subject to change.