

**AVENUE**

Avenue™ signal integration system

# Model 5340 Analog Key to Digital Converter Data Pack

**ENSEMBLE**

D E S I G N S

Revision 2.1 SW v1.0

This data pack provides detailed installation, configuration and operation information for the **5340 Ten Bit Analog Key to Digital Video Converter (ADC)** with the **5310/5315 TBC/Frame Synchronizer** option as part of the Avenue Signal Integration System.

The module information in this data pack is organized into the following sections:

- Module Overview
- Applications
- Installation
- Cabling
- Module Configuration and Control
  - Front Panel Controls and Indicators
  - Avenue PC Remote Control
  - Avenue Touch Screen Remote Control
- Troubleshooting
- Software Updating
- Warranty and Factory Service
- Specifications

## MODULE OVERVIEW

The 5340 Analog Key to Digital Converter (ADC) Module converts an analog key signal into a serial digital output for use in a digital environment. The digital output is distributed to four BNCs on the rear of the frame. One Key In BNC is provided for the input key signal. The reference input for genlocking to an external reference is only active if the 5310 or 5315 submodule is installed.

The input key signal is buffered, clamped and filtered before entering 10-bit analog to digital conversion circuitry. This video is processed through a digital processing amplifier then enters a 601 formatting circuit. It is then sent to EDH insertion processing and serializing circuitry before going to the four serial digital outputs.

If the optional 5310 or 5315 submodule is installed, time base correction (TBC) and frame synchronization allows for removal of time base error on the composite input. The reference input for the TBC functionality can be derived from a number of inputs to the module, including a reference BNC to the 5340, the System Control module in the frame or the incoming composite or component video. The 5315 submodule provides increased flexibility by offering a serial digital reference input. The options also allow the module to accept asynchronous inputs and deliver serial outputs locked and time to the house reference. Both the 5310 and 5315 options require the System Control module to be present in the frame.

Power is derived from the  $\pm 12$  volt frame power. It is regulated to the required +5 volts for the digital circuitry and  $\pm 8$  volts for the analog circuitry by on-board regulators. The module is fused with a resettable fuse device. If the fuse opens due to an overcurrent condition, the module will lose power. After pulling the module, the fuse will reset automatically requiring no replacement fuse.

The on-board CPU can monitor and report module ID information (slot location, software version and board revision), and power status (+5 volts or  $\pm 8$  volts) to the optional frame System Control module. This information can be accessed by the user or set to register an alarm if desired using the remote control options available.

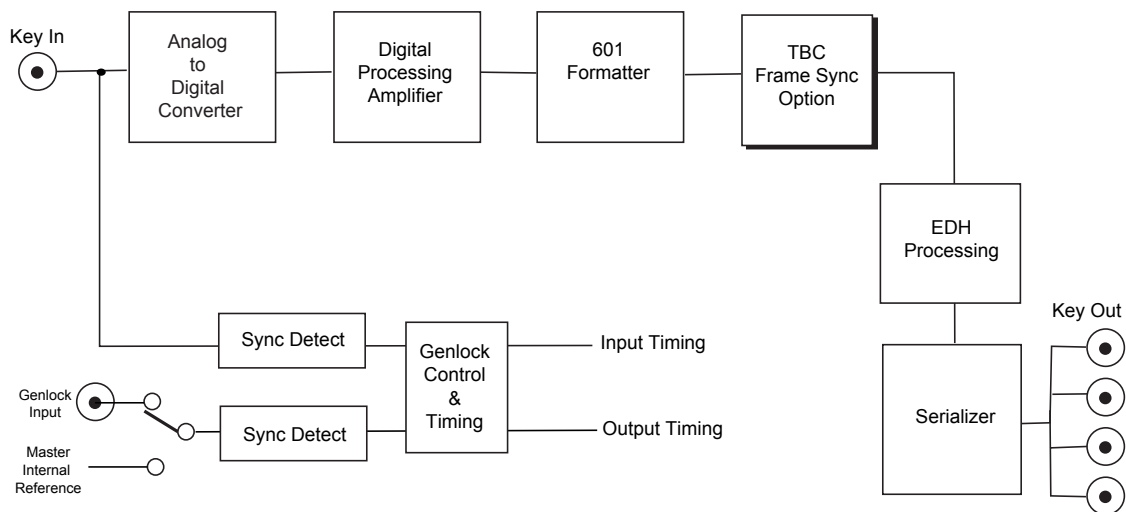

5340 Analog Key to Digital Video Converter Functional Block Diagram

**APPLICATIONS**

**Character Generator to Digital Switcher**

The application below illustrates utilizing the 5300 and the 5340 modules to convert a component analog output signal with key output from a character generator to digital signals for feeding a digital switcher.

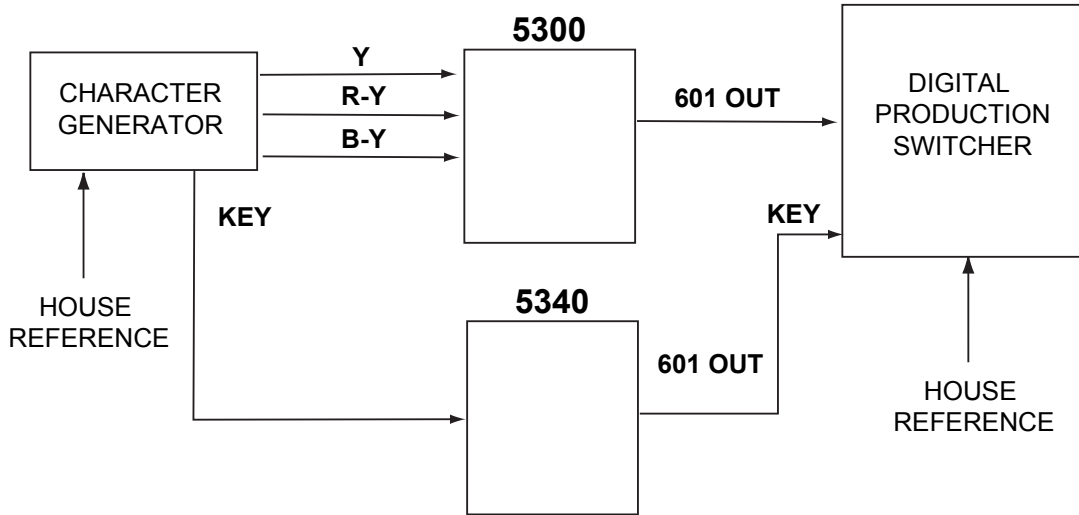

**Converting Analog Signals with 5340 and 5300**

## **INSTALLATION**

### **5310/15 Time Base Corrector/Frame Synchronizer Option**

Plug the 5310 or 5315 Time Base Corrector/Frame Synchronizer module onto the two 40-pin connectors on the component side of the 5340 Key ADC module. The connectors are keyed such that the submodule can only be installed to match the connector keying.

### **5340 ADC Module**

Plug the 5340 module into any slot in the 1 RU or 3 RU frame and install the plastic overlay provided onto the corresponding group of rear BNC connectors associated with the module location. Note that the plastic overlay has an optional adhesive backing for securing it to the frame. Use of the adhesive backing is only necessary if you would like the location to be permanent and is not recommended if you need to change module locations.

This module may be hot-swapped (inserted or removed) without powering down or disturbing performance of the other modules in the system.

## **CABLING**

Refer to the 3 RU and 1 RU backplane diagrams of the module on the next page for cabling instructions. Note that unless stated otherwise, the 1 RU cabling explanations are identical to those given in the 3 RU diagram.

3 RU Backplane

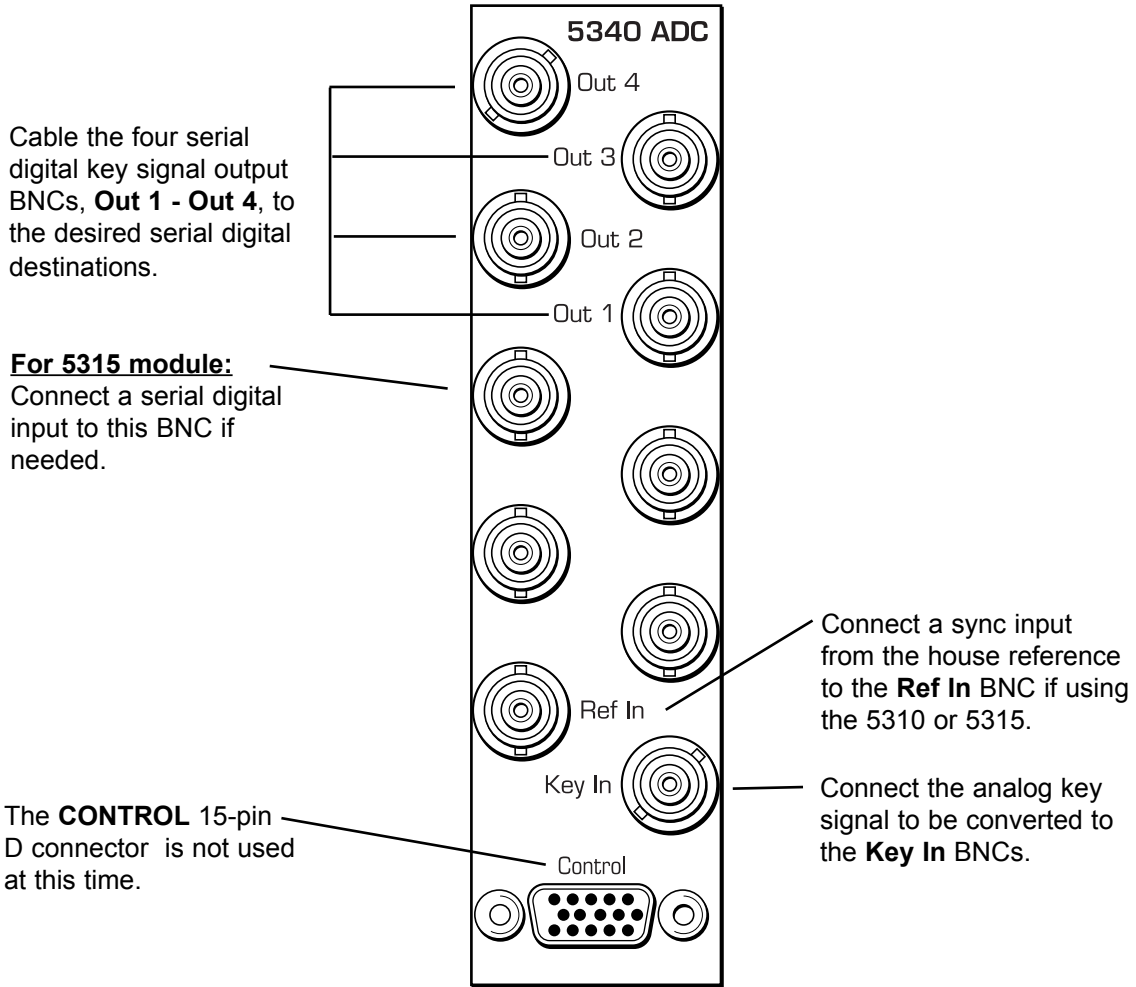

1 RU Backplane

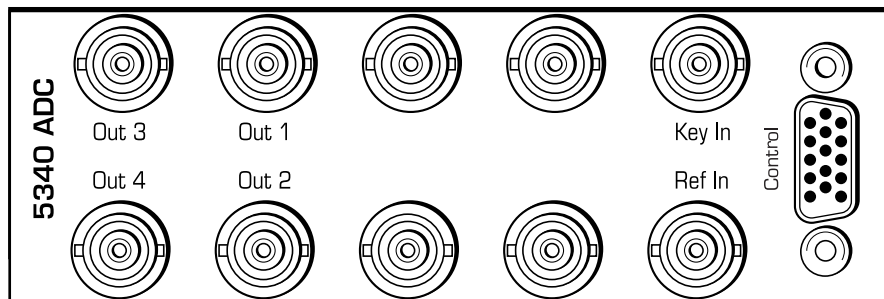

## MODULE CONFIGURATION AND CONTROL

The configuration parameters for each Avenue module must be selected after installation. This can be done remotely using one of the Avenue remote control options or locally using the module front panel controls. Each module has a **REMOTE/LOCAL** switch on the front edge of the circuit board which must first be set to the control mode you will be using.

The configuration parameter choices for the module will differ between **Remote** and **Local** modes. In **Remote** mode, the choices are made through software and allow more selections. The **5340 Parameter Table** on the following page summarizes and compares the various configuration parameters that can be set remotely or locally and the default/factory settings.

If you are not using an remote control option, the module parameters must be configured from the front panel switches. Parameters that have no front panel control will be set to a default value. The **Local** switches are illustrated in the **Front Panel Controls and Indicators** section following the **5340 Parameter Table**.

Avenue module parameters can be configured and controlled remotely from one or both of the remote control options, the Avenue Touch Screen or the Avenue PC Application. Once the module parameters have been set remotely, the information is stored on the module CPU. This allows the module be moved to a different cell in the frame at your discretion without losing the stored information. Remote configuration will override whatever the switch settings are on the front edge of the module.

For setting the parameters remotely using the Avenue PC option, refer to the **Avenue PC Remote Configuration** section of this document.

For setting the parameters remotely using the Avenue Touch Screen option, refer to the **Avenue Touch Screen Remote Configuration** section of this data pack following Avenue PC.

5340 Parameter Table

CONTROL	LOCAL	REMOTE	DEFAULT/FACTORY
Format	Switch 4: On Off	Key with setup Key w/o setup	On
Out Gain	100%	95-105%	100%
Pedestal	0	-2 to +10 IRE	0
Color Bar Generator	Switch 8: On Off	On Off	On
EDH Insert	On	On Off	On
Vert Blank	Wide	Wide Narrow	Wide
<b>If a 5310 or 5315 submodule option is installed and turned on, the following parameters are active:</b>			
Reference Source	External Reference	Video Input External Reference Master Reference	External Reference
TBC Control	Switch 6: On Off	On Off	Off
Mode	Slow	Very Slow Slow Fast Very Fast Frm Sync Only	Slow
Signal Mute	No Mute	Mutes on Noise No Mute	No Mute
Horizontal Video Position	0	-15 to 15 clocks	0
Horizontal Time	0	±1700 Clocks	0
Vertical Time	0	±625 lines	0

Note: If the TBC/FrameSync is turned off and video input is present, the module locks to the incoming video. Otherwise, the module locks to the selected reference, external module reference or master timing reference on the frame.

## Front Panel Controls and Indicators

Each front edge indicator and switch setting is shown in the diagram below:

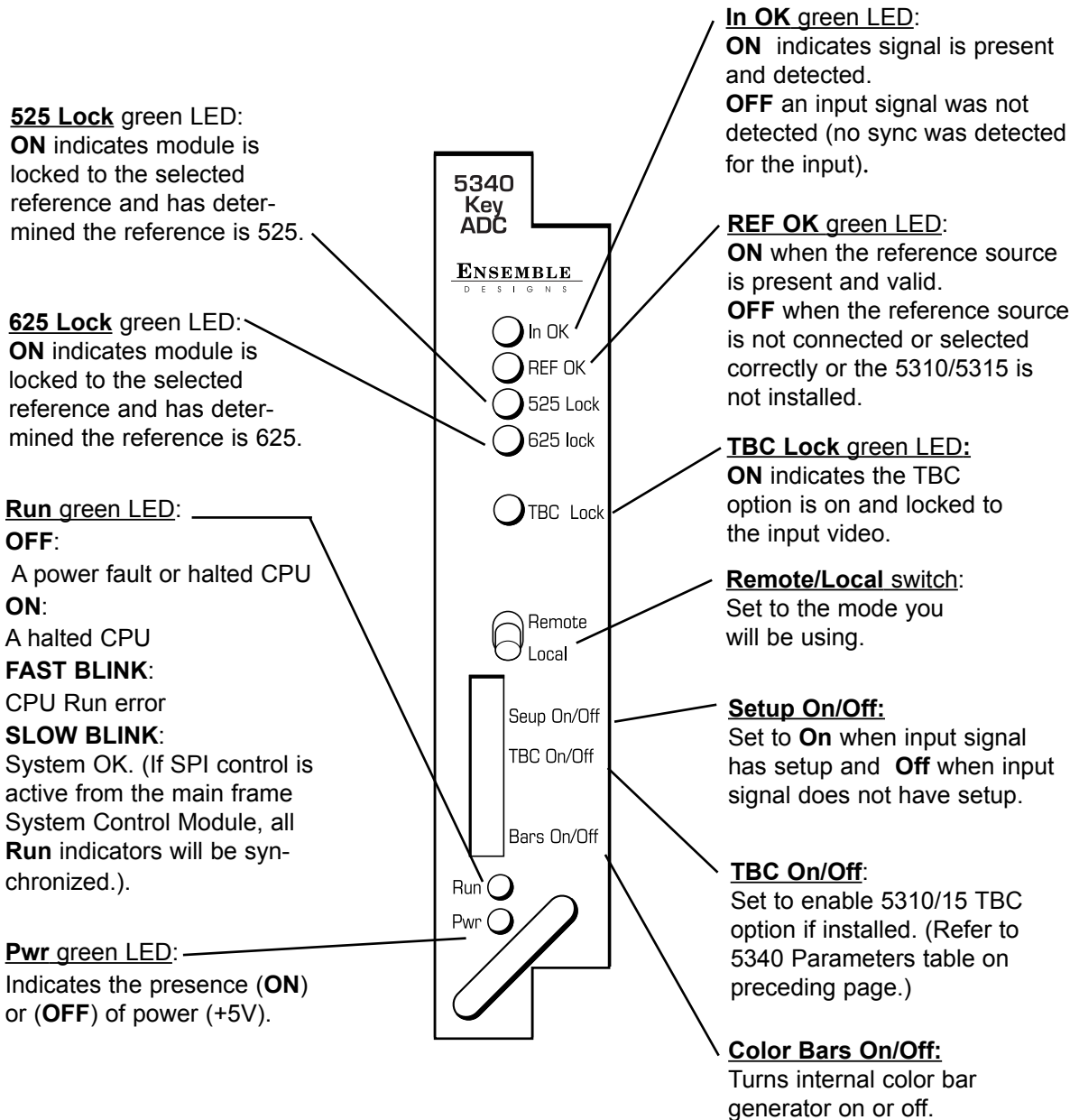

## Avenue PC Remote Configuration

The Avenue PC remote control menus for this module are illustrated and explained below. Refer to the 5340 Parameter Table shown earlier for a summary of available parameters that can be set remotely through the menus illustrated. For more information on using Avenue PC, refer to the Avenue PC Control Application Software data pack that came with the option.

### 5340 Avenue PC Menus

The **Input** menu below allows you to set the following parameters:

- **Format** - set for key input with setup or without setup.
- **Ref Source** - select the reference source for the module.

This menu also provides **Input**, **Reference** and **Lock State** status information about the module.

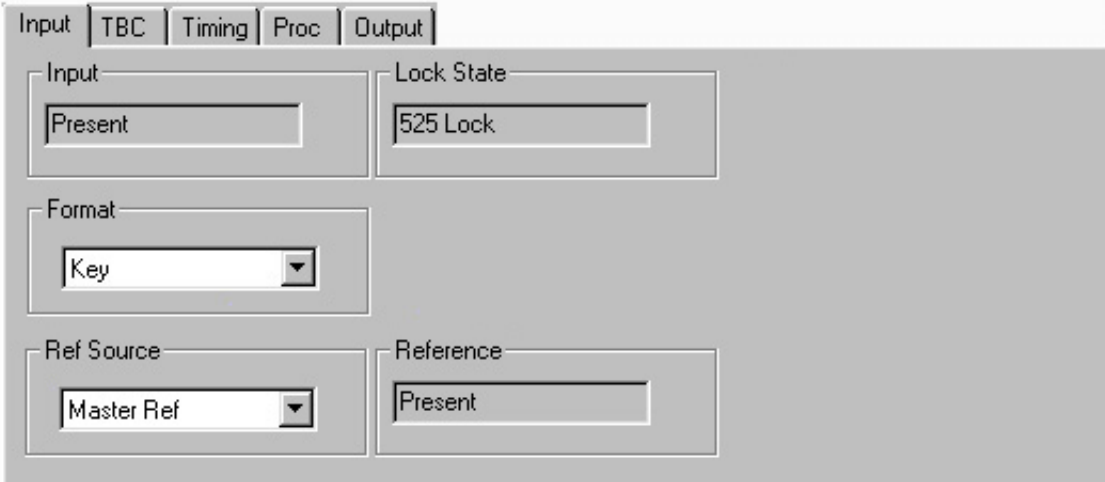

The screenshot shows a software interface with a tabbed menu. The 'Input' tab is selected. The interface contains the following elements:

- Input**: A text field containing 'Present'.
- Lock State**: A text field containing '525 Lock'.
- Format**: A dropdown menu with 'Key' selected.
- Ref Source**: A dropdown menu with 'Master Ref' selected.
- Reference**: A text field containing 'Present'.

## Model 5340 Key ADC

---

The **TBC** menu is used when the optional 5310 or 5315 Time Base Corrector (TBC)/Frame Synchronizer is installed on the 5340 module. The menu and parameters to be set for each option are shown below.

The **Option** display will indicate which option is installed or **None**.

Set the following parameters when the 5310 or 5315 option is installed:

- **TBC/FrmSync** – click in the box to turn on the TBC/FrameSync.
- **Mode** – determines the speed of error handling. For fast occurring errors, such as from a consumer VCR, use the **Very Fast** mode. Select the mode best for your source; **Very Fast**, **Fast**, **Slow** or **Very Slow**. If you have a retiming application where you don't need the TBC and just want the frame synchronizer, select **FrmSync Only**.
- **Signal Mute** – Choose between **Mutes on Noise** or **No Mute**. Select **No Mute** when you want to see an output signal even if the input is noisy, missing sync, or the signal is fading in and out. This mode is helpful when you are shuttling a VTR or using satellite feeds. If you prefer the output to go to black if the input is not stable, select **Mute on Noise**.

The **TBC Lock** status display reports which reference source the module is locking to.

The screenshot shows a software interface with a tabbed menu at the top containing 'Input', 'TBC', 'Timing', 'Proc', and 'Output'. The 'TBC' tab is selected. Below the tabs, there are several control elements:

- An 'Option' field with a text box containing '5315'.
- A 'TBC/FrmSync' field with a checked checkbox.
- A 'TBC Lock' field with a text box containing 'Master Ref'.
- A 'Mode' field with a dropdown menu showing 'FrmSync Only'.
- A 'Signal Mute' field with a dropdown menu showing 'Mutes on Noise'.

The **Timing** menu sets timing parameters when the optional 5310 or 5315 Time Base Corrector/Frame Sync option is installed on the 5340 module. Set the following timing parameters:

- **H Picture Pos** - sets the horizontal position of the picture in clocks when the TBC option is installed.
- **Hor Timing** - sets the horizontal output timing when the TBC option is enabled.
- **Ver Timing** - set the vertical output timing when the TBC option is enabled.

The **Delay** window is provided to show module delay in lines.

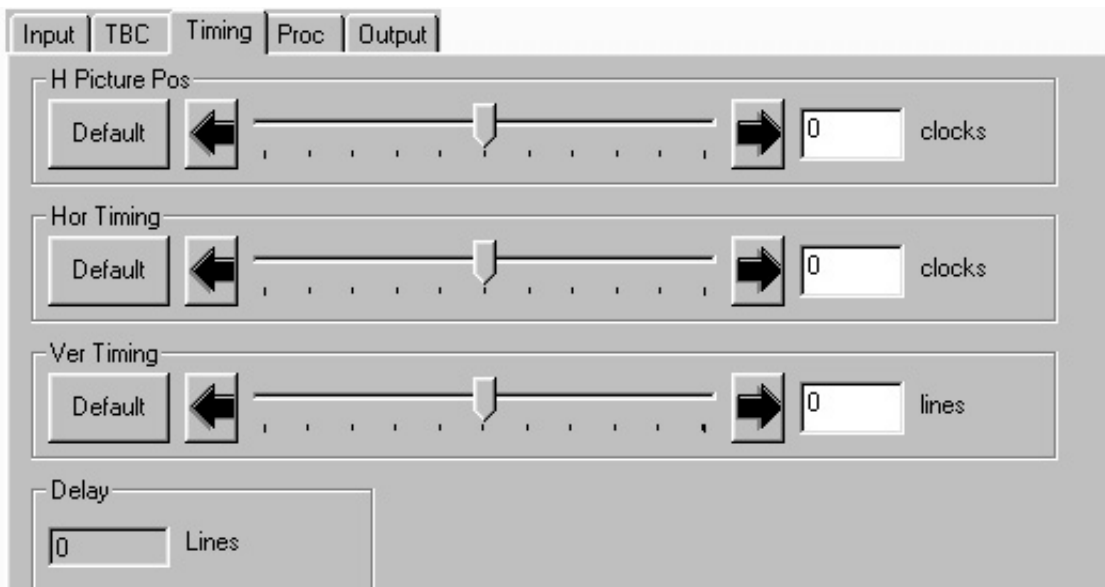

The **Proc** menu below provides the following adjustments for the serial digital output levels.

- **Video Gain** - adjusts the gain of the digital output signal.
- **Pedestal** - adjusts the black level of the digital output signal in IREs.

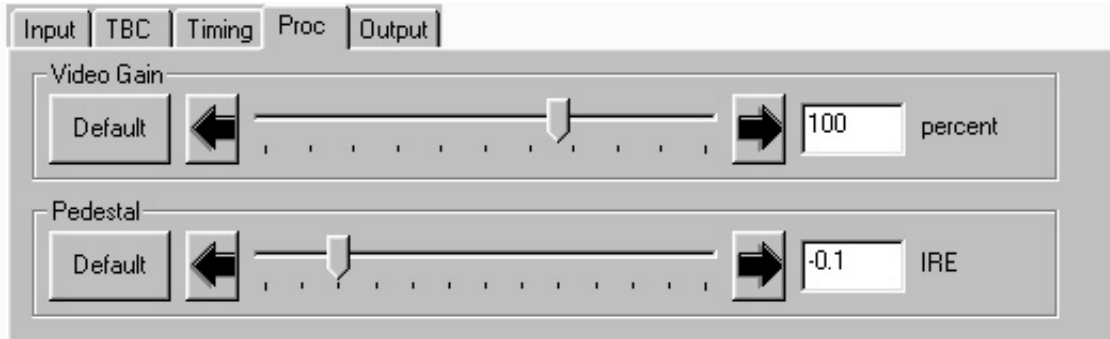

The **Output** menu below provides the following adjustments for the serial digital output.

- **Color Bar Gen** - click the box to enable the internally generated color bars on the output.
- **EDH Insert** - click the box to enable EDH insertion on the digital output.
- **Vert Blank** - set the vertical blanking to wide or narrow as needed for the output.

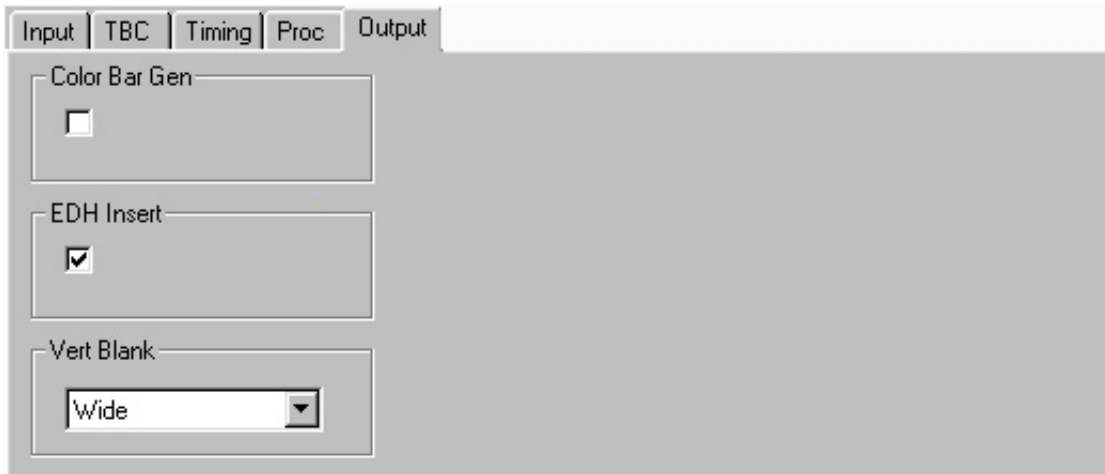

## Avenue Touch Screen Remote Configuration

Avenue Touch Screen remote control menus for this module are illustrated and explained below. Refer to the 5340 table earlier in this section for a summary of available parameters that can be set remotely through the menus illustrated. For more information on using Avenue Touch Screen, refer to the Avenue Touch Screen data pack that came with the option.

### 5340 Avenue Touch Screen Menus

The **Input** menu below allows you to set the following parameters:

- **Format** - set for key input with setup or without setup.
- **Ref Source** - select the reference source for the module.

This menu also provides **Input**, **Lock State**, and **Reference** status information about the module.

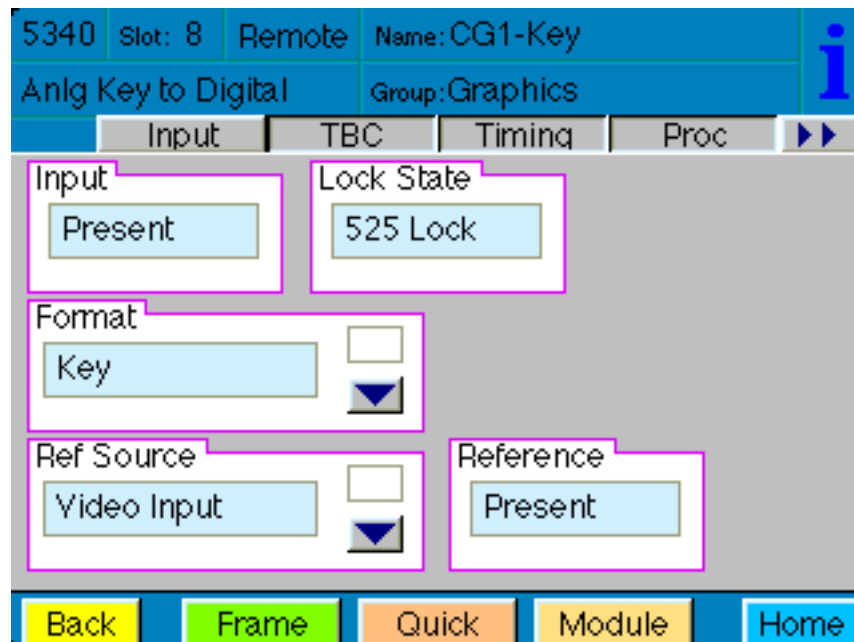

The **TBC** menu is used when the optional 5310 or 5315 Time Base Corrector (TBC)/Frame Synchronizer is installed on the 5300 module. The menu and parameters to be set for each option are shown below.

The **Option** display will indicate which option is installed or **None**.

Set the following parameters when the 5310 or 5315 option is installed:

- **TBC/FrmSync** – click in the box to turn on the TBC/FrameSync.
- **TBC Mode** – determines the speed of error handling. For fast occurring errors, such as from a consumer VCR, use the **Very Fast** mode. Select the mode best for your source; **Very Fast**, **Fast**, **Slow** or **Very Slow**. If you have a retiming application where you don't need the TBC and just want the frame synchronizer, select **FrmSync Only**.
- **Signal Mute** – Choose between **Mutes on Noise** or **No Mute**. Select **No Mute** when you want to see an output signal even if the input is noisy, missing sync, or the signal is fading in and out. This mode is helpful when you are shuttling a VTR or using satellite feeds. If you prefer the output to go to black if the input is not stable, select **Mute on Noise**.

The **TBC Lock** status display reports which reference source the module is locking to.

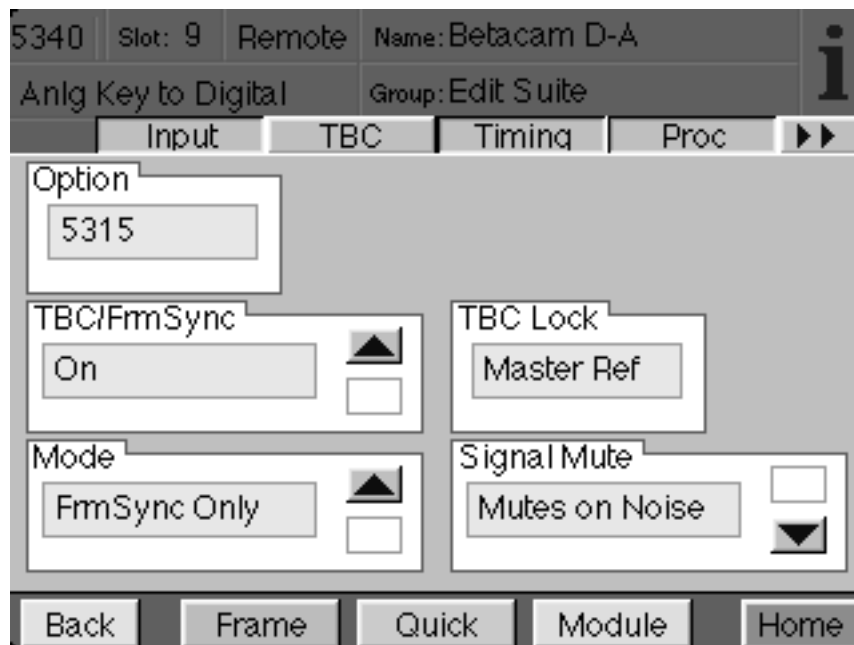

The **Timing** menu sets timing parameters when the optional 5310 or 5315 Time Base Corrector/Frame Sync option is installed on the 5340 module. Set the following timing parameters:

- **H Picture Pos** - sets the horizontal position of the picture in clocks when the TBC option is installed.
- **Hor Timing** - sets the horizontal output timing when the TBC option is enabled.
- **Ver Timing** - set the vertical output timing when the TBC option is enabled.

The **Delay** window is provided to show module delay in lines.

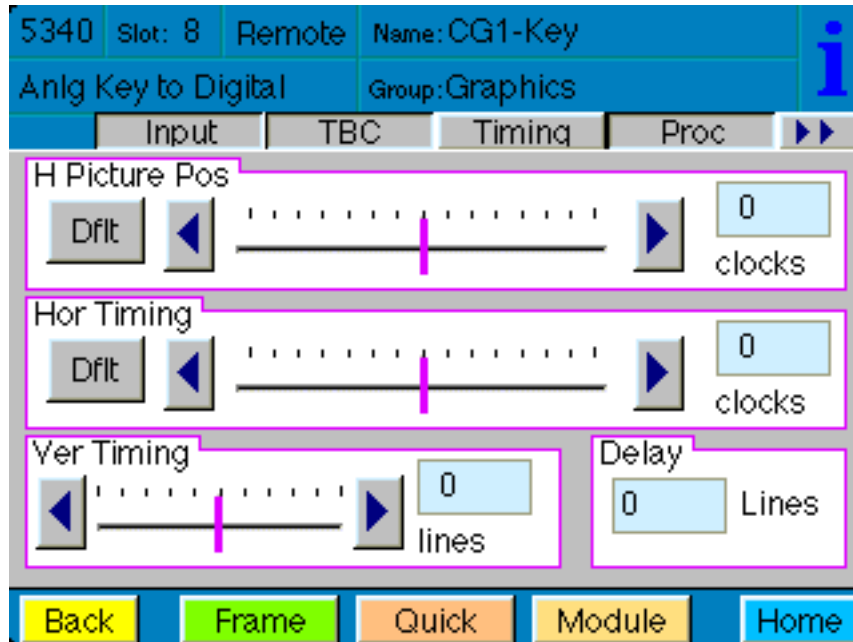

The **Proc** menu below provides the following adjustments for the serial digital output levels.

- **Video Gain** - adjusts the gain of the digital output signal.
- **Pedestal** - adjusts the black level of the digital output signal in IREs.

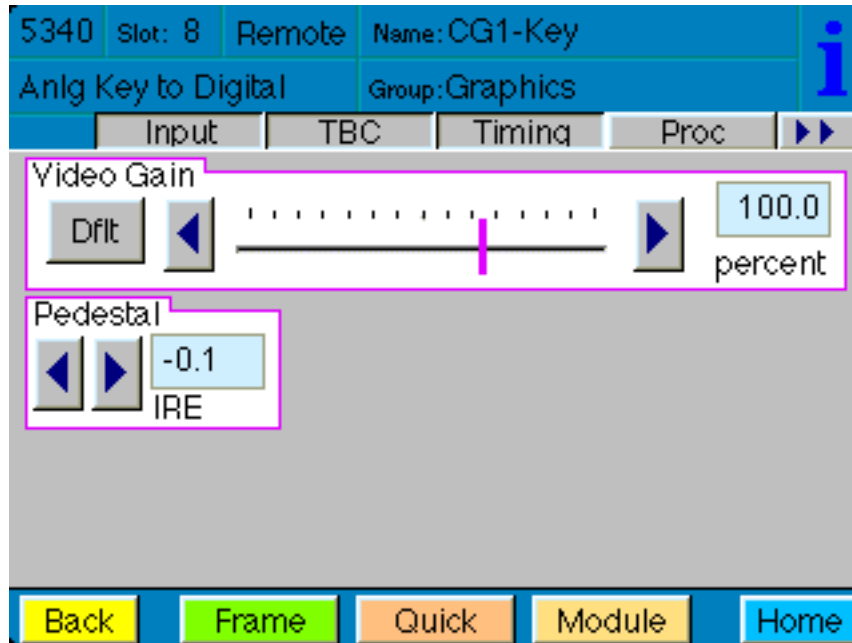

The **Output** menu below provides the following adjustments for the serial digital output.

- **Color Bar Gen** - click the box to enable the internally generated color bars on the output.
- **EDH Insert** - click the box to enable EDH insertion on the digital output.
- **Vert Blank** - set the vertical blanking to wide or narrow as needed for the output.

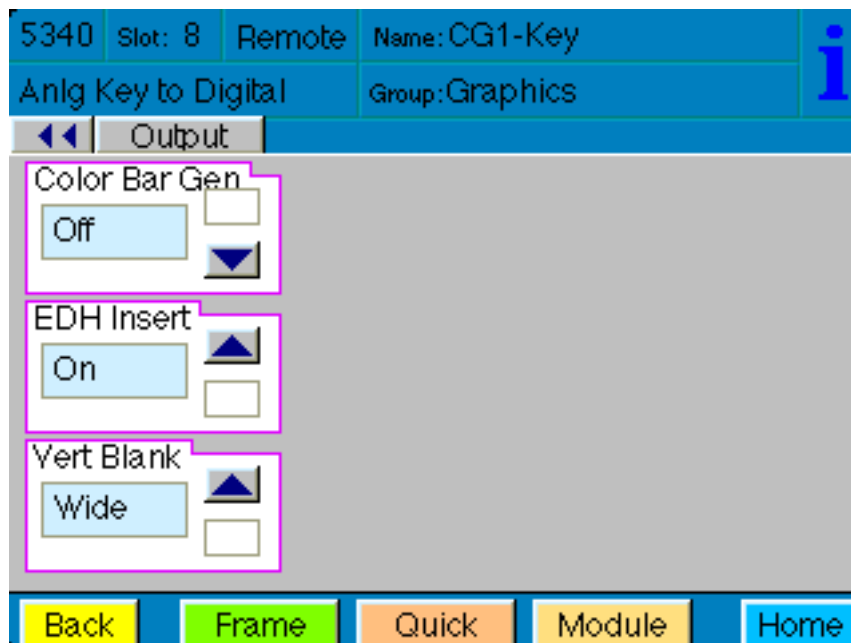

## TROUBLESHOOTING

To aid in troubleshooting, the LED indicators can be easily monitored from the front panel of this module to show status of the module.

If using the **Remote** mode, the following status items can be monitored using the Avenue Touch Screen Control Panel or PC Application:

- In OK
- Reference OK
- 525/625 Lock
- Power status
- Slot ID, Software Version and Board Revision

Refer to the overall troubleshooting tips given below for the module:

### **No status lights are lit on front panel:**

- Check that frame power is present (green LED{s} on frame power supplies).
- Check that module is firmly seated in frame. Try removing it and plugging it in again.

### **Can't control module:**

- Check status of CPU **Run** green LED. Should be blinking slowly and in unison with other modules if System module is present. If not, try removing it and plugging it in again.
- System module may not be working properly if installed.

### **No signal out of module:**

- Check status of **In OK** green LED. Should be lit. If not, check the input signal for presence and quality.
- Check cabling to input of module.

You may also refer to the technical support section of the Ensemble or Graham-Patten web sites for the latest information on your equipment at the URLs below:

<http://www.ensembledesigns.com/support>

<http://www.grahampatten.com>

## SOFTWARE UPDATING

Software upgrades for each module can be downloaded remotely if the optional System Control module is installed. These can be downloaded onto your PC and then Avenue PC will distribute the update to the individual module. (Refer to the Avenue PC documentation for more information) Periodically updates will be posted on our web site. If you do not have the required System Control Module and Avenue PC, modules can be sent back to the factory for software upgrades.

## WARRANTY AND FACTORY SERVICE

### Warranty

This Module is covered by a five year limited warranty, as stated in the main Preface of this manual. If you require service (under warranty or not), please contact Ensemble Designs or Graham-Patten Systems and ask for customer service before you return the unit. This will allow the service technician to provide any other suggestions for identifying the problem and recommend possible solutions.

### Factory Service

If you return equipment for repair, please get a Return Material Authorization Number (RMA) from the factory first.

Ship the product and a written description of the problem to:

Ensemble Designs, Inc.

Attention: Customer Service RMA #####

870 Gold Flat Rd.

Nevada City, CA. 95959 USA

(530) 478-1830

Fax: (530) 478-1832

service@endes.com

<http://www.ensembledesigns.com>

Be sure to put your RMA number on the outside of the box.

### OR

Graham-Patten Systems, Inc.

13366 Grass Valley Avenue

Grass Valley, CA 95945

(800) 422-6662 or (530) 273-8412

Fax: (530) 273-7458

service@gpsys.com

<http://www.grahampatten.com>

---

## SPECIFICATIONS

### 5340 Key ADC

#### Key Input

Number	One
Impedance:	75 ohm BNC
Return Loss:	> 40dB
Output DC:	< $\pm 50$ mV
Input Hum:	< 100 mV

#### Serial Output Signal

Number:	Four
Signal Type:	Serial Digital (SMPTE 259M)
Impedance:	75 ohm
Return Loss:	>15 dB
Output DC:	None (AC coupled)

#### Reference Input

Number:	One external One internal master timing ref
Signal Type:	1V p-p nominal composite video PAL or NTSC
Return Loss:	> 40dB (applies to ext ref input)

#### Output Performance

Bit Resolution:	10 bit, 2x oversampling
Noise:	54dB
Black Offset:	Self-adjusting
Response:	0 to 5.5 MHz $\pm 0.1$ dB

#### General Specifications

Power Consumption:	< 7.0 watts
Temperature Range:	0 to 40 degrees C ambient (all specs met)
Relative Humidity:	0 to 95% noncondensing
Altitude:	0 to 10,000 ft

Due to ongoing product development, all specifications subject to change.