

Model 5280 Digital to Analog Composite Video Converter Data Pack

ENSEMBLE

D E S I G N S

Revision 2.1 SW v2.0

This data pack provides detailed installation, configuration and operation information for the **5280 Digital to Analog Composite Video Converter** and the **5210 Genlock** option submodule as part of the Avenue Signal Integration System.

The module information in this data pack is organized into the following sections:

- Module Overview
- Applications
- Installation
- Cabling
- Module Configuration and Control
 - Front Panel Controls and Indicators
 - Avenue PC Remote Control
 - Avenue Touch Screen Remote Control
- Troubleshooting
- Software Updating
- Warranty and Factory Service
- Specifications

MODULE OVERVIEW

The 5280 module converts serial digital component video into composite analog video. Six separate composite or two Y/C (S-video) analog video outputs are available. The following analog formats are supported:

- NTSC Composite with or without setup
- PAL Composite

A serial output BNC is provided for applications requiring the serial digital input signal to loop-through to another device.

Output timing can be adjusted relative to a reference input signal by installing the 5210 Genlock Option, a submodule that plugs onto the 5280 circuit board. Incorporating a full-frame synchronizer, the 5210 also allows the 5280 to accept serial inputs that are asynchronous to the reference.

As shown in the block diagram on the following page, the serial digital input signal first passes through serial receiver circuitry then on to EDH processing and deserializing. The serial output signal goes to a cable driver and is then AC coupled to a loop-through output BNC on the backplane. This input signal can now be looped to another device.

The deserialized video output enters genlock timing circuitry if the optional 5210 is installed. The 5210 Genlock submodule provides fully adjustable output timing for the analog outputs from the 5280 module with respect to a reference input. The reference input can be from one of three sources: the digital input to the module, the external reference input BNC specific to that module slot, or the master reference input (a loop through BNC pair on the rear of the chassis which feeds reference to all ten modules through a buffer amplifier located on the System Control module). In the second and third cases the reference source would be a composite video signal, typically color black.

When using the 5210 submodule option, the System Control module is recommended. With the System Control module installed in the frame, Touch Screen and Avenue PC can be used to adjust module parameters such as output timing. Without the System Control module, the output video is in time with the external reference video feeding the module.

Fine timing adjustments can be accessed by remote control using one of the Avenue remote applications. Local control of the 5280 module sets the timing of the analog outputs to be aligned with the selected input reference and is fixed.

The 5210 submodule interfaces to the circuit board of the 5280 through two 40-pin headers. Power comes from the main module + 5 and ± 8 volt regulators. Timing delay on the submodule is provided by memory ICs which are controlled by circuitry which generates timing locked to the reference input of the 5200 module (either internal or external).

The deserialized video is encoded then converted to analog before entering the analog clamp and output circuitry. The video output format desired can be chosen locally by setting the front panel switches or remotely by the Avenue applications as explained in the Front Panel Controls and Indicators section of this data pack.

The on-board CPU can monitor and report module ID information (slot location, software version and board revision), equalization (cable length), receiver status (lock and TRS errors), power status (+5 volts or ± 8 volts), ancillary data status (presence of EDH flags and CRC, frequency of errors, audio and other data) to the optional frame System Control module. This information can be accessed by the user or set to register an alarm if desired using the remote control options available.

Every function and parameter on the module can be controlled from an Avenue Touch Screen Control Panel, or the Avenue PC Control Application. Memory registers can be used to save the complete configuration of the module, making it easy to change instantly between different configurations.

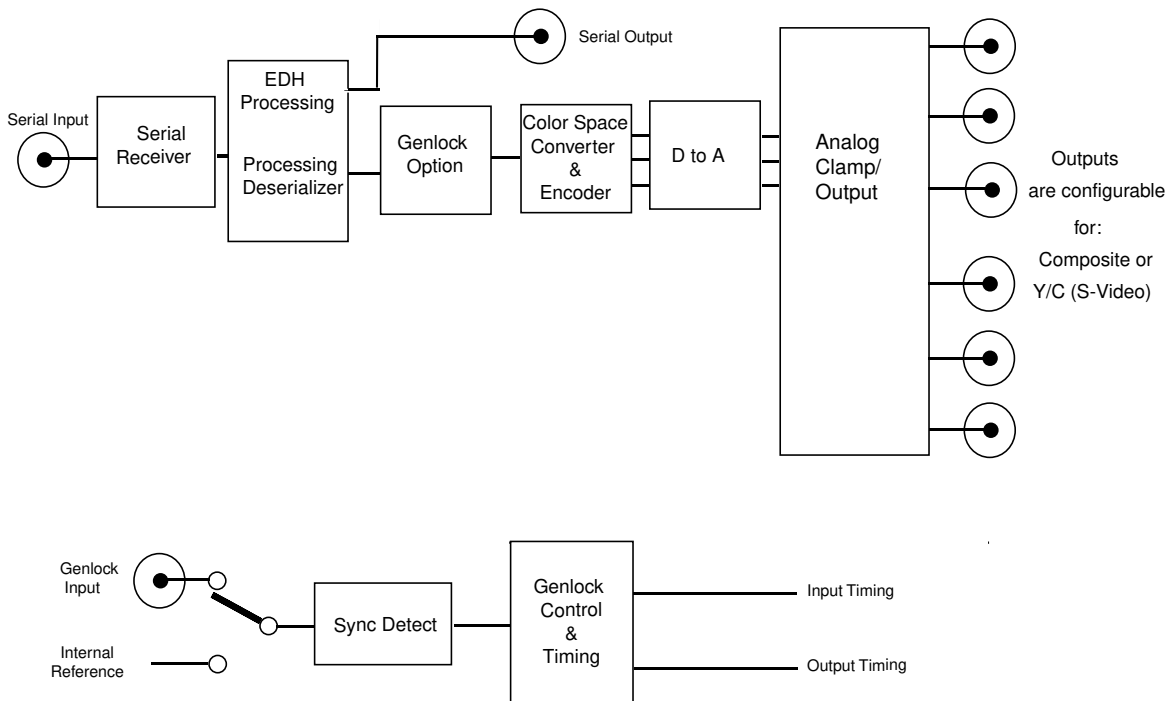

5280/5210 Digital to Analog Composite Video Converter Functional Block Diagram

APPLICATIONS

Composite Encoder for Transmission

The 5280 can convert the output of a digital master control switcher to composite video to feed a transmitter as shown in the block diagram below. The other five composite outputs can be fed to other destinations such as a composite monitor or any other standard composite device.

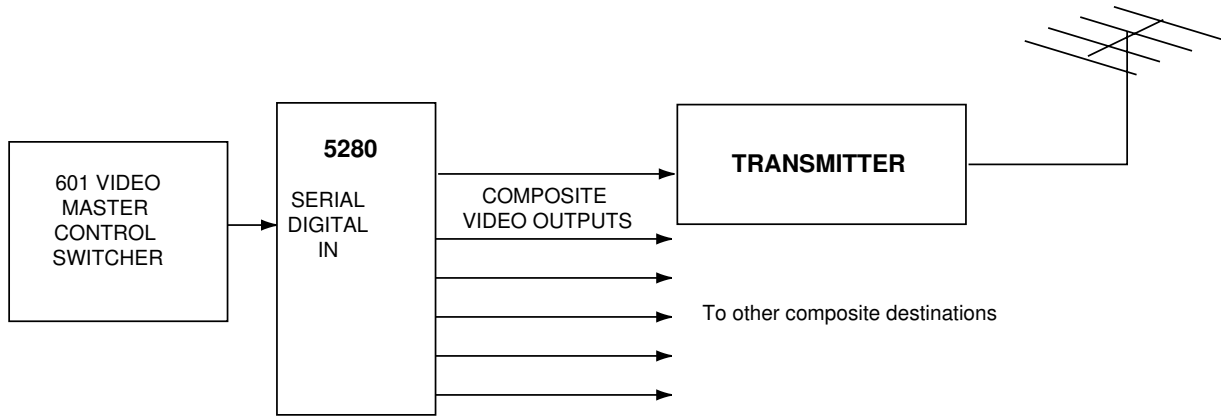

Serial Digital to Composite Encoder for Transmission Application

Serial Digital to Composite with Re-timing

The 5280 with the optional 5210 Genlock/Frame Synchronizer installed allows output signals to be timed independently of the input. This provides timing options for applications requiring timing to a house reference, such as the application shown below. In this case, a serial digital signal is converted to analog composite by the 5280 and feeds an analog production switcher. The input signal to the switcher can then be adjusted for proper timing with respect to other sources.

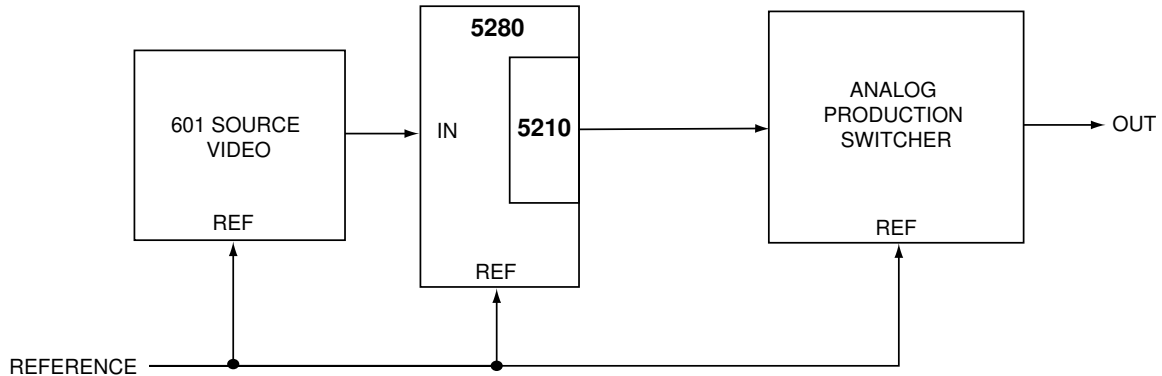

Serial Digital to Composite for Re-timing Application

Serial Digital to S-Video Applications

The 5280 can convert serial digital video into two sets of S-Video outputs for feeding any type of S-Video device such as a monitor or tape machine as shown in the application below. Refer to the backplane diagram later in this document for cabling details.

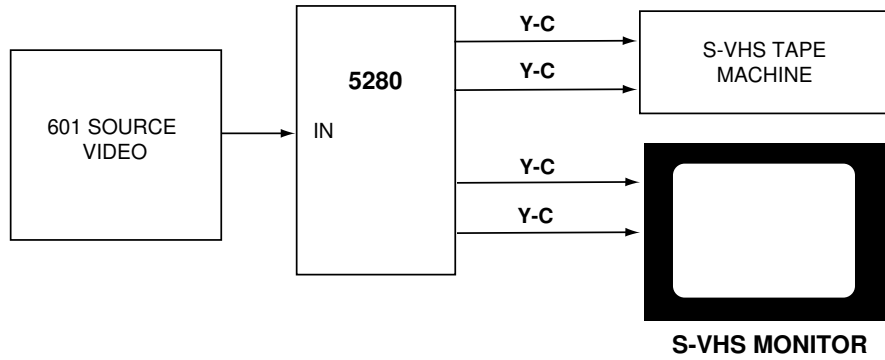

Serial Digital to S-Video Application

INSTALLATION

5210 Genlock Option

Plug the 5210 Genlock submodule onto the two 40-pin connectors on the component side of the 5280 Composite Video DAC module. The connectors are keyed such that the submodule can only be installed to match the connector keying.

5280 DAC Module

Plug the 5280 module into any slot in the 1 RU or 3 RU frame and install the plastic overlay provided onto the corresponding group of rear BNC connectors associated with the module location. Note that the plastic overlay has an optional adhesive backing for securing it to the frame. Use of the adhesive backing is only necessary if you would like the location to be permanent and is not recommended if you need to change module locations.

This module may be hot-swapped (inserted or removed) without powering down or disturbing performance of the other modules in the system.

CABLING

Refer to the 3 RU and 1 RU backplane diagrams of the module on the next page for cabling instructions. Note that unless stated otherwise, the 1 RU cabling explanations are identical to those given in the 3 RU diagram.

3 RU Backplane

For **S-Video** output operation:
 Connect one set of output destinations to BNCs:
 S-C1 and S-Y1.
 Connect the other output destinations to BNCs:
 S-C2 and S-Y2.

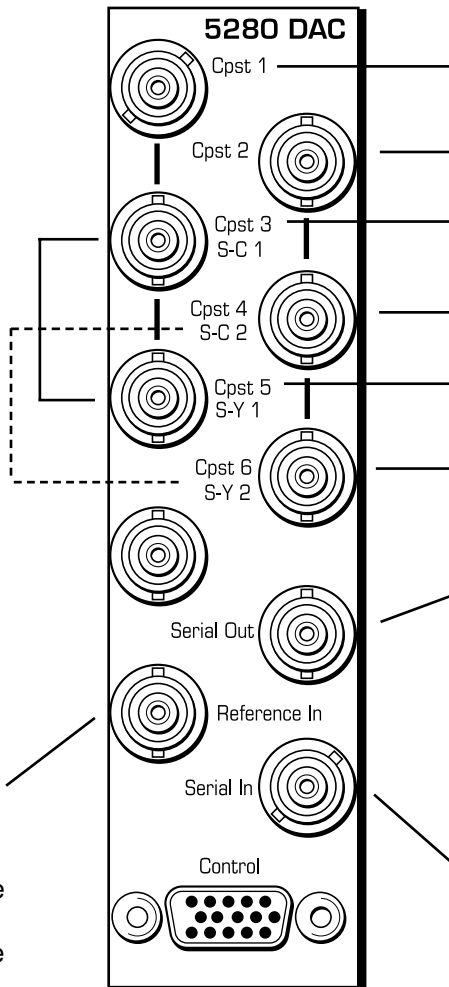

For **Composite** output operation: Connect the six output BNCs to analog composite destinations.

Connect a cable from the **Serial Out** BNC to loop-through to another digital video device if desired.

Connect a sync input from the house reference to the **Ref In** BNC if using the 5210. Or if you want to lock the composite color field sequence of the monitor output. Alternately, use the master timing reference input on the frame.

Connect the serial digital signal to be converted to the **Serial In** BNC.

1 RU Backplane

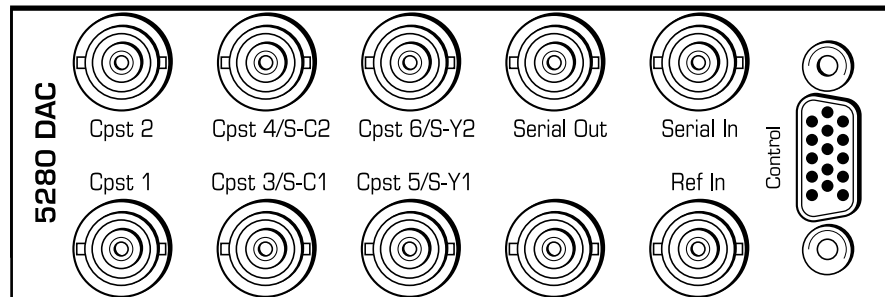

MODULE CONFIGURATION AND CONTROL

The configuration parameters for each Avenue module must be selected after installation. This can be done remotely using one of the Avenue remote control options or locally using the module front panel controls. Each module has a **REMOTE/LOCAL** switch on the front edge of the circuit board which must first be set to the control mode you will be using.

The configuration parameter choices for the module will differ between **Remote** and **Local** modes. In **Remote** mode, the choices are made through software and allow more selections. The **5280 Parameter Table** on the following page summarizes and compares the various configuration parameters that can be set remotely or locally and the default/factory settings.

If you are not using a remote control option, the module parameters must be configured from the front panel switches. Parameters that have no front panel control will be set to a default value. The **Local** switches are illustrated in the **Front Panel Controls and Indicators** section following the **5280 Parameter Table**.

Avenue module parameters can be configured and controlled remotely from one or both of the remote control options, the Avenue Touch Screen or the Avenue PC Application. Once the module parameters have been set remotely, the information is stored on the module CPU. This allows the module be moved to a different cell in the frame at your discretion without losing the stored information. Remote configuration will override whatever the switch settings are on the front edge of the module.

For setting the parameters remotely using the Avenue PC option, refer to the **Avenue PC Remote Configuration** section of this document.

For setting the parameters remotely using the Avenue Touch Screen option, refer to the **Avenue Touch Screen Remote Configuration** section of this data pack following Avenue PC.

5280 Parameter Table

CONTROL	LOCAL	REMOTE	DEFAULT	USER LEVEL
Format	Switch 1: Cpst S-Vid	Composite S-Video	Composite	User 3
Setup	Switch 4: On Off	On Off	On	User 3
Reference Source	External	Digital In Ext Reference Master Ref	Digital In	User 3
Color Lock	Normal	2 Field Normal Field 3 Field 5 Field 7	2 Field	User 3
Max Cable	300 meters	0 – 350 meters	0 meters	User 3
Test Signal Enable	N/A	On Off	Off	User 2
Test Signal Type	N/A	Modulated Ramp 75% Bars 100% Bars	75% Bars	User 2
Vertical Blanking	Switch 5: On (Narrow) Off (Wide)	Lines 6 – 25	Line 20	User 3
EDH Insert	Switch 6: On Off	On Off	On	User 3
Fine Phase	N/A	+/- 70 nsec	0 nsec	User 3
Horizontal Timing	N/A	+/- 1716 clocks	0 clocks	User 3
Vertical Timing	N/A	+/- 525 lines	0 lines	User 3
Gain	N/A	0 – 120%	100%	User 1
Chroma	N/A	0 – 110%	100%	User 1
Hue (NTSC)	N/A	+/- 45 degrees	0 degrees	User 1
Pedestal	N/A	+/- 10 IRE	0 IRE	User 1
Memory Registers	N/A	1 – 5	Last Saved	User 3

Front Panel Controls and Indicators

Each front edge indicator and switch setting is shown in the diagram below:

EQ OK green LED:

ON indicates signal is present and equalized for all outputs.
OFF indicates the signal may not be present or equalized.

EDH green LED:

ON when EDH is present (ancillary data is detected).
OFF when no EDH ancillary data is detected.

EDH Err red LED:

ON when EDH is present and CRC errors are detected.
OFF when EDH is not present or CRC errors are not detected.

Ref Pres green LED:

ON when valid reference is present. **OFF** when reference not present.

Run green LED:

OFF:
 A power fault or halted CPU
ON:
 A halted CPU
FAST BLINK:
 CPU Run error
SLOW BLINK:
 System OK. (If SPI control is active from the main frame System Control Module, all **Run** indicators will be synchronized.)

Pwr green LED:

Indicates the presence (**ON**) or absence (**OFF**) of power (+5V).

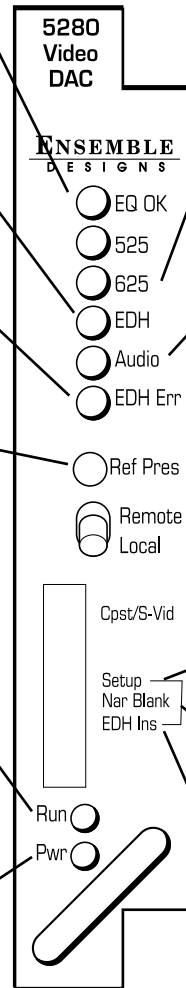

525 or 625 LOCK green LEDs:

ON when the equalization is correct and the serial receiver has successfully locked to the 525 or 625 data stream clock.
OFF when equalization is incorrect and the serial receiver has not successfully locked to either data stream clock.

Audio green LED:

ON when an audio ancillary packet is detected.
OFF when no audio ancillary packet is detected.

Remote/Local switch:

Set to the mode you will be using.

Cpst/S-Vid switch:

Set module output to **Cpst** (left) or **S-Vid** (right).

Setup:

Set the output to **Setup** (left) or no **Setup** (right) for NTSC outputs only.

Nar Blank switch:

Set to left for Narrow Blanking (blanking ends on line 10/NTSC, Line 6/PAL), right for Wide Blanking (blanking ends on line 20/NTSC or Line 25/PAL).

EDH Ins switch:

Set to **On** (left) to insert EDH or **Off** (right) to not insert EDH into serial digital video output.

Avenue PC Remote Configuration

The Avenue PC remote control menus for this module are illustrated and explained below. Refer to the **5280 Parameter Table** for a summary of available parameters that can be set remotely through the menus illustrated. For more information on using Avenue PC, refer to the Avenue PC Control Application Software data pack that came with the option.

Parameter fields that are grayed out can indicate one of the following conditions:

- An option is not installed.
- The function is not active.
- The User Level set with Avenue PC is not accessible from the current User Level.

5280 Avenue PC Menus

In the **Format** menu shown below, set the following parameters:

- **Format** – set the desired format for the module outputs.
- **Setup** – enable or disable for setup on the output signal.
- **Ref Source** – choose the reference source for the module.
- **Color Lock** – determines where the ScH color field sequence will occur on the output signal in relation to the input. This setting applies to **Composite** signals only. Set to **2 Field**, the output ScH phase may be in or out of phase with the input (arbitrary). Set to **4 Field Norm**, the output ScH phase will match the input. Set to **4 Field Invert**, the output will be out of phase with the input.

The following status items are reported in the **Format** menu:

- **Reference** – shows status of reference input to module.
- **Option** – indicates the presence of the 5210 Genlock option installed on the module.

The screenshot shows the 'Format' menu of the Avenue PC remote control. The menu is divided into several sections: 'Format', 'Setup', 'Ref Source', 'Reference', 'Color Lock', and 'Option'. Each section contains a control element (a dropdown menu or a text field) with its current value displayed.

Format	Serial	Output	Timing	Proc	Memory
Format					
Composite					
Setup					
On					
Ref Source					
Digital In					
Reference					
Present					
Color Lock					
2 Field					
Option					
5210					

In the **Serial** menu shown below, the following parameters can be set:

- **Max Cable** – set the maximum cable length to be equalized.

Module information for the following items is provided in the **Serial** menu:

- **Equalizer** – indicates if input is present and equalized for all outputs.
- **PLL Lock** – indicates equalization is correct and the serial receiver has successfully locked to the data stream clock.
- **Cable Length** – indicates length of cable being equalized.
- **EDH** – indicates if EDH is present.
- **Audio** – indicates presence of audio ancillary data.
- **EDH Error** – indicates presence of CRC errors in EDH.

The screenshot shows the 'Serial' menu with the following settings:

Parameter	Value
Equalizer	Input OK
PLL Lock	525 Lock
Cable Length	0 meters
EDH	No EDH
Audio	No Audio
EDH Error	No EDH
Max Cable	300 meters (slider set to 300)

Set the **Output** menu items below:

- **Test On/Off** – turns the test signal on or off.
- **Test Signal** – select the type of test signal; 75% Bars, 100% Bars, or Ramp.
- **Vert Blanking** – set end of blanking to desired line number (NTSC 10 – 20 line range or PAL 6 – 25 line range).
- **EDH Insert** – set to **On** or **Off** to enable or disable EDH insertion into the Serial output video.

The screenshot shows the 'Output' menu with the following settings:

Parameter	Value
Test On/Off	<input type="checkbox"/> On
Test Signal	75% Bars
Vert Blanking	20
EDH Insert	<input checked="" type="checkbox"/> On

The **Timing** menu below is used when the optional 5210 Genlock submodule is installed on the 5280. Set the timing selections as follows, in the order given:

- **Vert Timing** – set the vertical timing to a typical setting of 0 lines.
- **Hor Timing** – adjust the horizontal timing of the output signal to place the leading edge of sync coincident with the other sources.
- **Fine Phase** – adjust for proper ScH phase with respect to the other sources.
NOTE: If Fine Phase will not adjust properly, readjust the horizontal phase by up to ± 2 clocks until the Fine Phase falls into place.

The number of lines of delay will be reported in the **Delay** window.

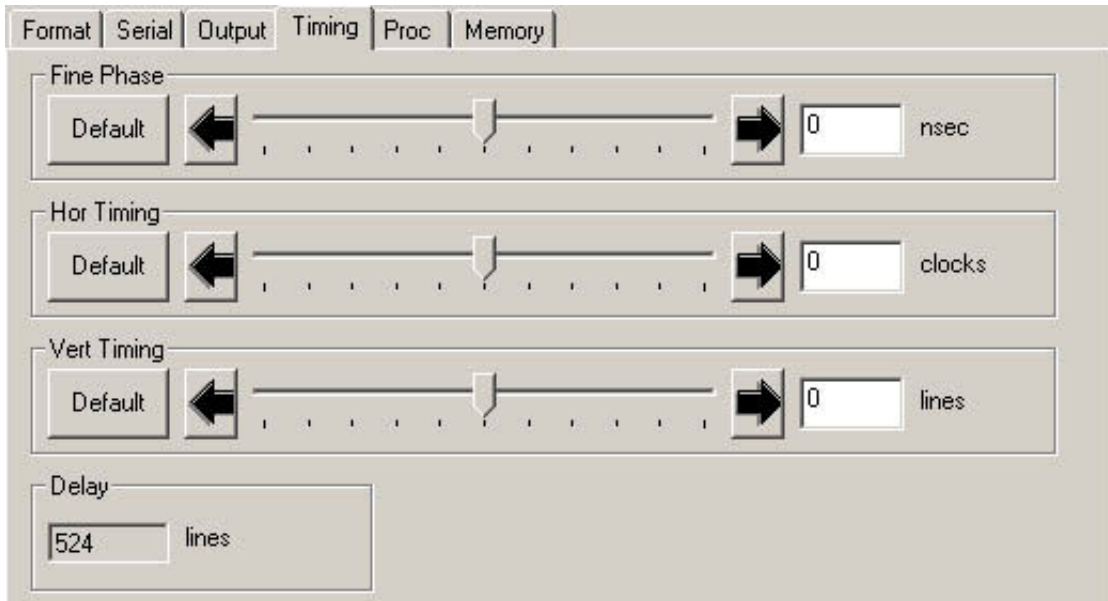

The **Proc** menu below allows adjustment of the following analog composite video parameters:

- **Gain** – adjusts the composite output gain.
- **Chroma** – adjusts the amount of chroma gain on the output.
- **Hue** – adjusts the hue of the composite output signal (NTSC only).
- **Pedestal** – adjusts the pedestal level of the output signal.

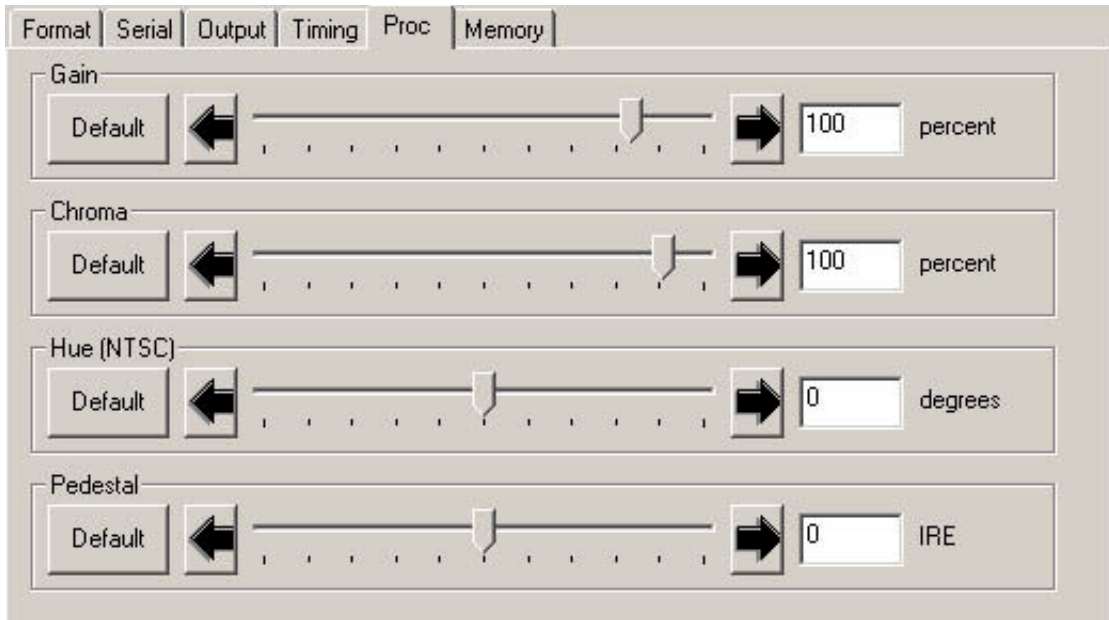

The **Memory** menu allows you to save overall module setups to five memory registers as follows:

- Select **Save** (it will light red), then select one of the five memory registers **Reg 1 – 5**. The selected box will turn green. The entire module setup is now saved in the selected register.
- To recall a register, select the register box. If there is information saved, the box will turn green. The saved setup will now be loaded to the module. Up to five different module setups can be saved and recalled using the individual registers.

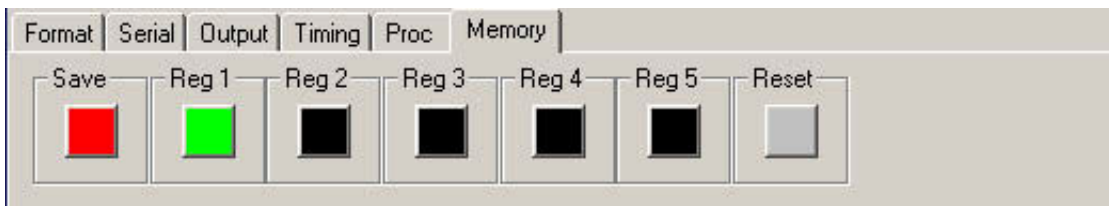

Avenue Touch Screen Remote Configuration

Avenue Touch Screen remote control menus for this module are illustrated and explained below. Refer to the **5280 Parameter Table** for a summary of available parameters that can be set remotely through the menus illustrated. For more information on using Avenue Touch Screen, refer to the Avenue Touch Screen data pack that came with the option.

Parameter fields that are grayed out can indicate one of the following conditions:

- An option is not installed.
- The function is not active.
- The User Level set with Avenue PC is not accessible from the current User Level.

5280 Avenue Touch Screen Menus

In the **Format** menu shown below, set the following parameters:

- **Format** – set the desired format for the module outputs.
- **Setup** – enable or disable for setup on the output signal.
- **Ref Source** – choose the reference source for the module.
- **Color Lock** – determines where the ScH color field sequence will occur on the output signal in relation to the input. This setting applies to **Composite** signals only. Set to **2 Field**, the output ScH phase may be in or out of phase with the input (arbitrary). Set to **4 Field Norm**, the output ScH phase will match the input. Set to **4 Field Invert**, the output will be out of phase with the input.

The following status items are reported in the **Format** menu:

- **Reference** – shows status of reference input to module.
- **Option** – indicates the presence of the 5210 Genlock option installed on the module.

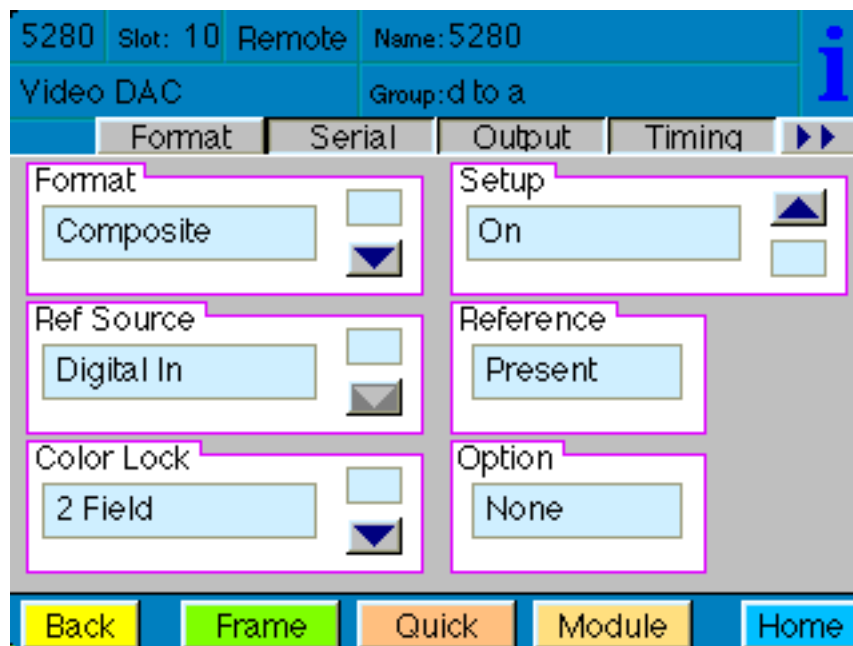

In the **Serial** menu shown below, the following parameters can be set:

- **Max Cable** – set the maximum cable length to be equalized.

Module information for the following items is provided in the **Serial** menu:

- **Equalizer** – indicates if input is present and equalized for all outputs.
- **PLL Lock** – indicates equalization is correct and the serial receiver has successfully locked to the data stream clock.
- **Cable Length** – indicates length of cable being equalized.
- **EDH** – indicates if EDH is present.
- **Audio** – indicates presence of audio ancillary data.
- **EDH Error** – indicates presence of CRC errors in EDH.

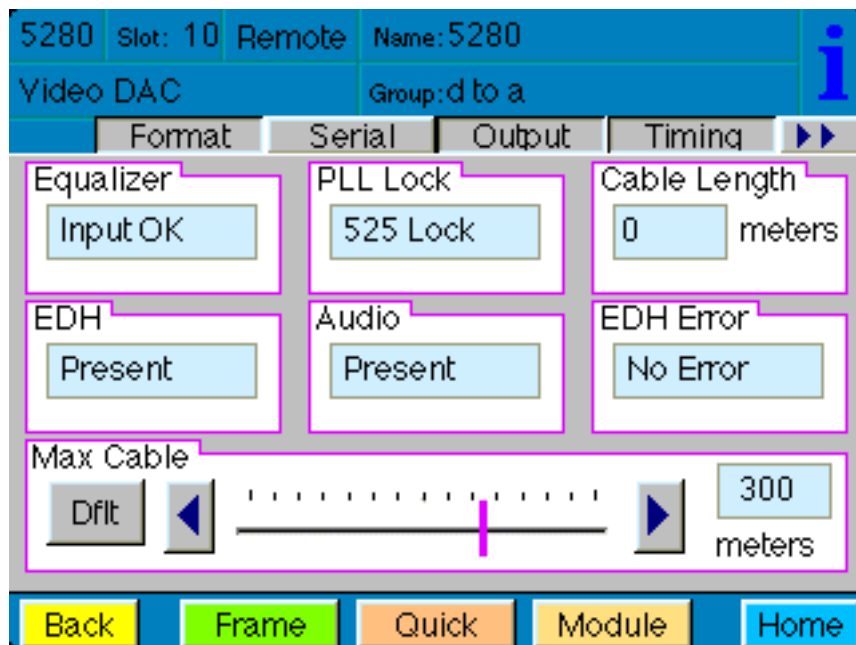

Set the **Output** menu items below:

- **Test On/Off** – turns the test signal on or off.
- **Test Signal** – select the type of test signal; 75% Bars, 100% Bars, or Ramp.
- **Vert Blanking** – set end of blanking to desired line number (NTSC 10 – 20 line range or PAL 6 – 25 line range).
- **EDH Insert** – set to **On** or **Off** to enable or disable EDH insertion into the Serial output video.

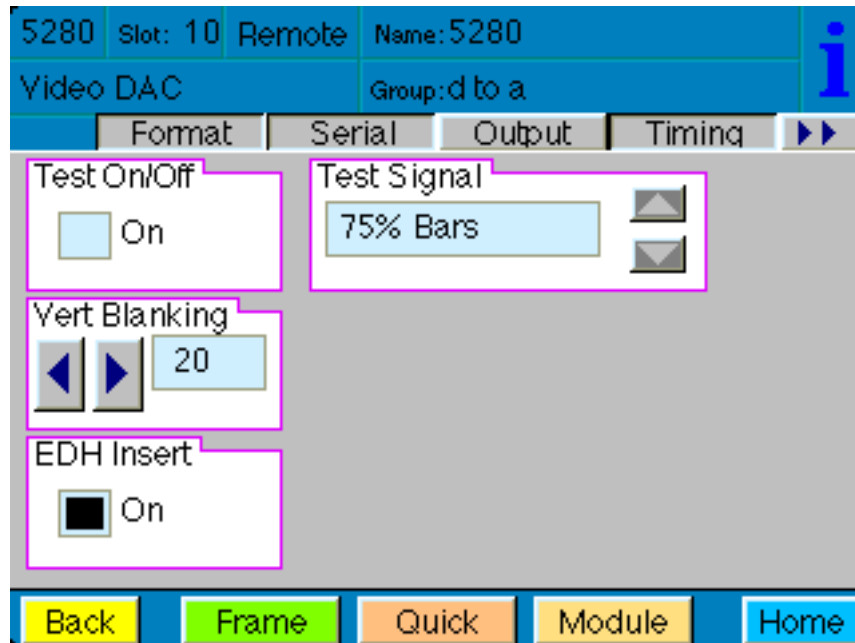

The **Timing** menu below is used when the optional 5210 Genlock submodule is installed on the 5200. Set the timing selections as follows, in the order given:

- **Vert Timing** – set the vertical timing to a typical setting of 0 lines.
- **Hor Timing** – adjust the horizontal timing of the output signal to place the leading edge of sync coincident with the other sources.
- **Fine Phase** – adjust for proper ScH phase with respect to the other sources.
NOTE: If Fine Phase will not adjust properly, readjust the horizontal phase by up to ± 2 clocks until the Fine Phase falls into place.

The number of lines of delay will be reported in the **Delay** window.

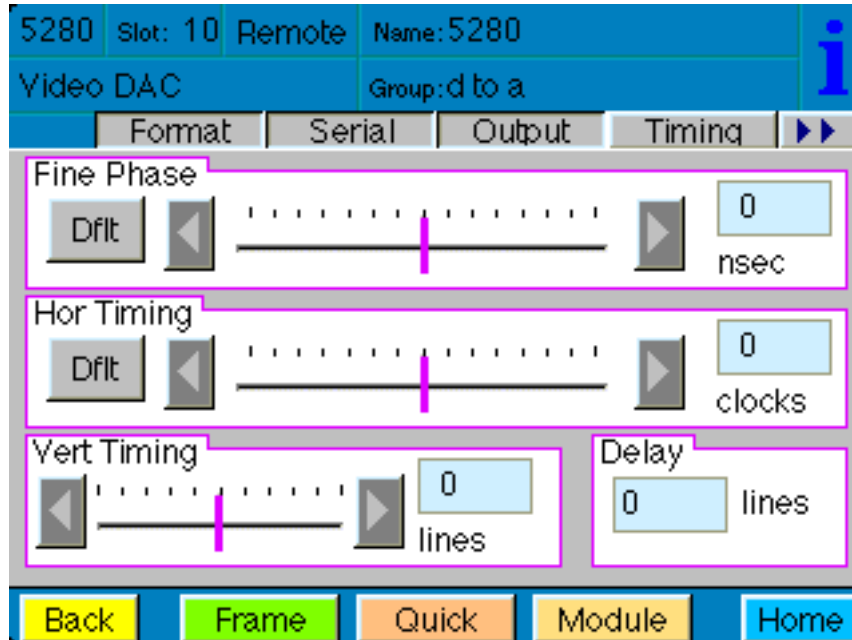

The **Proc** menu below allows adjustment of the following analog composite video parameters:

- **Gain** – adjusts the composite output gain.
- **Chroma** – adjusts the amount of chroma gain on the output.
- **Hue** – adjusts the hue of the composite output signal (NTSC only).
- **Pedestal** – adjusts the pedestal level of the output signal.

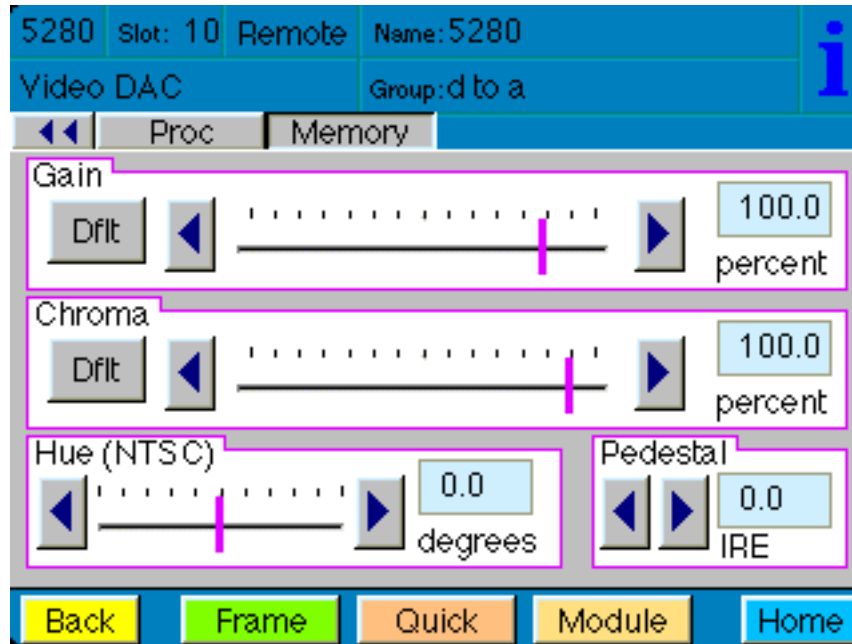

The **Memory** menu allows you to save overall module setups to five memory registers as follows:

- Select **Save** (it will light red), then select one of the five memory registers **Reg 1 – 5**. The selected box will turn green. The entire module setup is now saved in the selected register.
- To recall a register, select the register box. If there is information saved, the box will turn green. The saved setup will now be loaded to the module. Up to five different module setups can be saved and recalled using the individual registers.

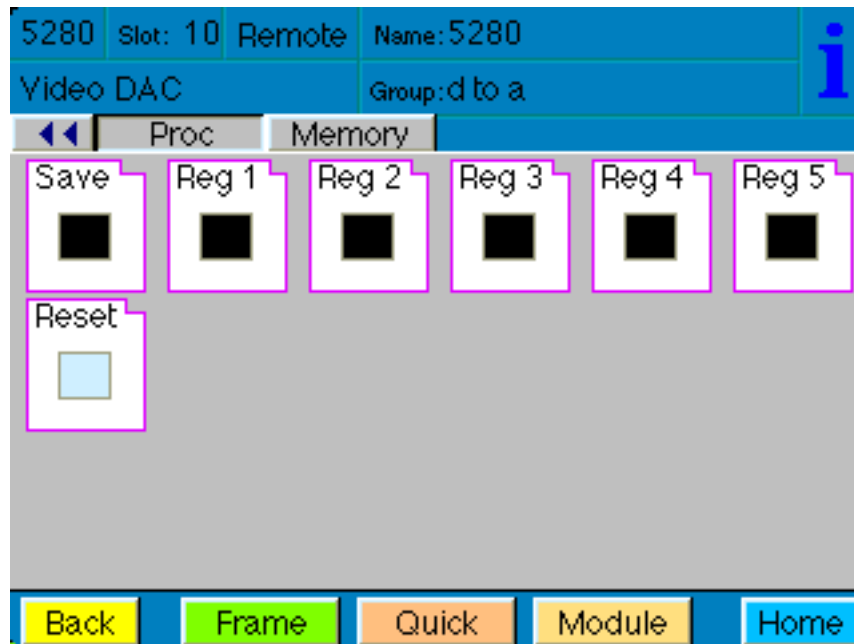

TROUBLESHOOTING

To aid in troubleshooting, the signal equalization and presence, 525/625 Lock, EDH errors, power and CPU status can be easily monitored from the front panel of this module using the indicators explained in the previous section.

If using the **Remote** mode, the following status items can be monitored using the Avenue Touch Screen Control Panel or PC Application:

- Equalization (cable length)
- 525/625 Lock
- EDH Errors
- Audio Presence
- Power status
- Slot ID, Software Version and Board Revision

Refer to the overall troubleshooting tips given below for the module:

No status lights are lit on front panel:

- Check that frame power is present (green LED{s} on frame power supplies).
- Check that module is firmly seated in frame. Try removing it and plugging it in again.

Can't control module:

- Check status of CPU **Run** green LED. Should be blinking slowly and in unison with other modules if System module is present. If not, try removing it and plugging it in again.
- System module may not be working properly if installed.

No signal out of module:

- Check status of **EQ OK** green LED. Should be lit. If not, check the input signal for presence and quality.
- Check cabling to input of module.
- Check remote cable equalization by switching the module to **Local** using the front panel switch and see if the EQ OK LED comes on.

EDH Error detected:

- Check cable connection at source and input to module
- Check integrity of signal at source

You may also refer to the technical support section of the Ensemble web site for the latest information on your equipment at the URL below:

<http://www.ensembledesigns.com/support>

SOFTWARE UPDATING

Software upgrades for each module can be downloaded remotely if the optional 5030 (3 RU frame) or 5035 (1 RU frame) Control module is installed. These can be downloaded onto your PC and then the Avenue PC application must be used to distribute the update to the individual module. (Refer to the Avenue PC documentation for more information) Periodically updates will be posted on our web site. If you do not have the required System Control Module and Avenue PC, modules can be sent back to the factory for software upgrades.

WARRANTY AND FACTORY SERVICE

Warranty

This Module is covered by a five year limited warranty, as stated in the main Preface of this manual. If you require service (under warranty or not), please contact Ensemble Designs and ask for customer service before you return the unit. This will allow the service technician to provide any other suggestions for identifying the problem and recommend possible solutions.

Factory Service

If you return equipment for repair, please get a Return Material Authorization Number (RMA) from the factory first.

Ship the product and a written description of the problem to:

Ensemble Designs, Inc.

Attention: Customer Service RMA #####

870 Gold Flat Rd.

Nevada City, CA. 95959 USA

(530) 478-1830

Fax: (530) 478-1832

service@endes.com

<http://www.ensembledesigns.com>

Be sure to put your RMA number on the outside of the box.

SPECIFICATIONS**5280 Video DAC****Serial Input:**

Number:	One
Signal Type:	Serial Digital (SMPTE 259M)
Impedance:	75 ohm
Return Loss:	>15 dB
Maximum Cable Length:	300 meters

Reference Input:

Number:	One external One internal master timing ref
Signal Type:	1V p-p nominal composite video PAL or NTSC
Return Loss:	> 40 dB (applies to ext ref input)

Serial Output:

Number:	One
Signal Type:	Serial Digital (SMPTE 259M)
Impedance:	75 ohm
Return Loss:	>15 dB
Output DC:	None (AC coupled)

Analog Outputs:

Number	6 sets composite or 2 sets Y/C
Impedance:	75 ohm BNC
Signal Type:	NTSC, PAL
Return Loss:	> 40 dB
Output DC:	< ± 50 mV
Frequency Response:	± 0.15 dB to 5 MHz
K Factors:	< 1.0%
SCH Phase Error:	< ± 2 degrees
Differential Phase	1 degree
Differential Gain	1%
Color Field sequence	Locked to selected ref
D to A Resolution	12 bit processing, 10 bit, 4x oversampled, 8:8:8 reconstruction
Signal to Noise	> 61 dB

General Specifications:

Connectors: BNC
Power Consumption: < 7 Watts
Temperature Range: 0 to 40 degrees C ambient (all specs met)
Relative Humidity: 0 to 95% noncondensing
Altitude: 0 to 10,000 ft
Fusing: 1.5 Amp PTC resettable fuse

Due to ongoing product development, all specifications subject to change.