

Model 5200 Digital to Analog Video Converter and 5210 Genlock Option Data Pack

ENSEMBLE

DESIGNS

Revision 5.1 SW v2.0

This data pack provides detailed installation, configuration and operation information for the **5200 Digital to Analog Video (DAC) Converter** and the **5210 Genlock** option submodule as part of the Avenue Signal Integration System.

The module information in this data pack is organized into the following sections:

- Module Overview
- Applications
- Installation
- Cabling
- Module Configuration and Control
 - Front Panel Controls and Indicators
 - Avenue PC Remote Control
 - Avenue Touch Screen Remote Control
- Troubleshooting
- Software Updating
- Warranty and Factory Service
- Specifications

MODULE OVERVIEW

The 5200 module converts digital component video into either composite or component analog video outputs. Two sets of analog component video outputs are available or six separate composite outputs can be accessed.

The following analog formats are supported:

- RGB without setup, sync on green
- SMPTE Y,Cr,Cb
- Beta Y,Cr,Cb with setup
- NTSC Composite with or without setup
- PAL Composite
- S-Video (Y/C)
- MII Format (Remote Mode only)

A serial output BNC is provided for applications requiring the serial digital input signal to loop-through to another device.

Output timing can be adjusted relative to a reference input signal by installing the 5210 Genlock Option, a submodule that plugs onto the 5200 circuit board. Incorporating a full-frame synchronizer, the 5210 also allows the 5200 to accept serial inputs that are asynchronous to the reference.

As shown in the block diagram on the following page, the serial digital input signal first passes through serial receiver circuitry then on to EDH processing and deserializing. The serial output signal goes to a cable driver and is then AC coupled to a loop-through output BNC on the backplane. This input signal can now be looped to another device.

The deserialized video output enters genlock timing circuitry if the optional 5210 is installed. The 5210 Genlock submodule provides fully adjustable output timing for the analog outputs from the 5200 Video DAC with respect to a reference input. The reference input can be from one of three sources: the digital input to the module, the external reference input BNC specific to that module slot, or the master reference input (a loop through BNC pair on the rear of the chassis which feeds reference to all ten modules through a buffer amplifier located on the System Control module). In the second and third cases the reference source would be a composite video signal, typically color black.

When using the 5210 submodule option, the System Control module is recommended. With the System Control module installed in the frame, Touch Screen and Avenue PC can be used to adjust module parameters such as output timing. Without the System Control module the output video is in time with the external reference video feeding the module.

The 5210 submodule interfaces to the circuit board of the 5200 through two 40-pin headers. Power comes from the main module + 5 and ± 8 volt regulators. Timing delay on the submodule is provided by memory ICs which are controlled by circuitry which generates timing locked to the reference input of the 5200 module (either internal or external).

Fine timing adjustments can be accessed by remote control using one of the Avenue remote applications. Local control of the 5200 module sets the timing of the analog outputs to be aligned with the selected input reference and is fixed. When the submodule is installed on the 5200, the timing signals are disabled on the main module and those of the submodule are substituted as illustrated in the block diagram on the next page.

The deserialized video is encoded then converted to analog before entering the analog clamp and output circuitry. The format of video desired can be chosen locally by setting the front panel switches or remotely by the Avenue applications as explained in the Front Panel Controls and Indicators section of this data pack.

Power is derived from the ± 12 volt frame power. It is regulated to the required +5 volts for the digital circuitry and ± 8 volts for the analog circuitry by on-board regulators. The module is fused with a resettable fuse device. If the fuse opens due to an overcurrent condition, the module will lose power. After pulling the module, the fuse will reset automatically requiring no replacement fuse.

The on-board CPU can monitor and report module ID information (slot location, software version and board revision), equalization (cable length), receiver status (lock and TRS errors), power status (+5 volts or ± 8 volts), ancillary data status (presence of EDH flags and CRC, frequency of errors, audio and other data) to the optional frame System Control module. This information can be accessed by the user or set to register an alarm if desired using the remote control options available.

Every function and parameter on the 5200 module can be controlled from an Avenue Touch Screen Control Panel, or the Avenue PC Control Application. Memory registers can be used to save the complete configuration of the module, making it easy to change instantly between different configurations.

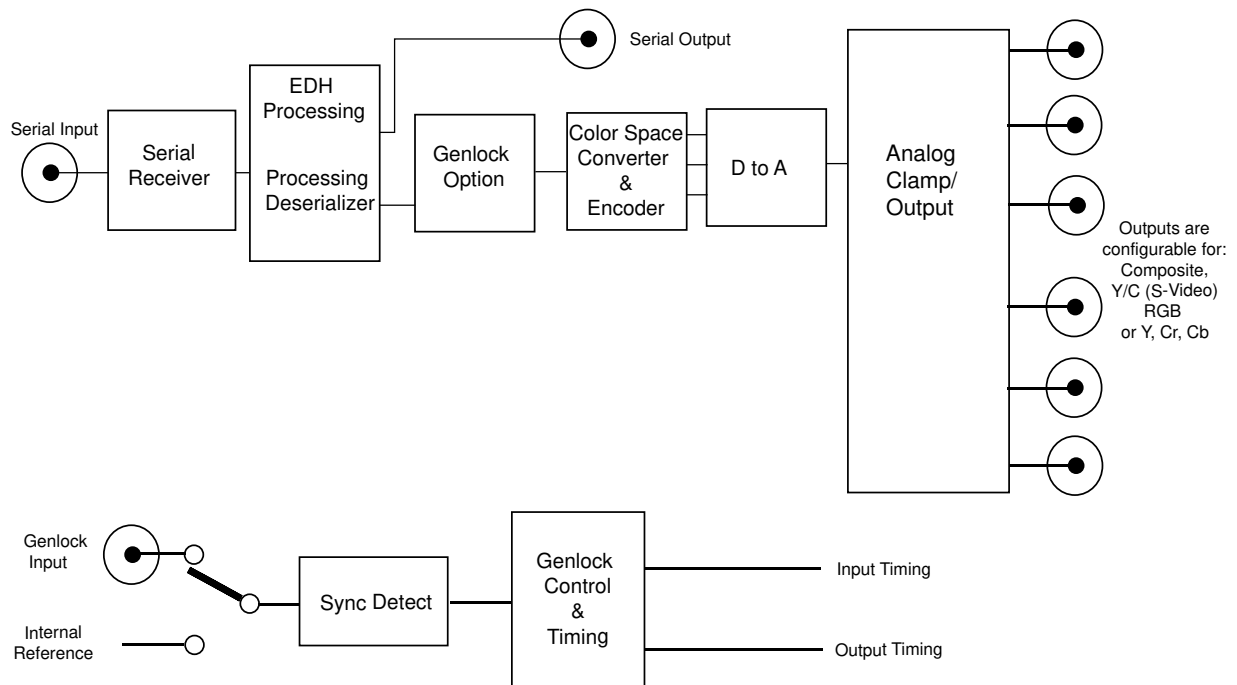

5200/5210 Video DAC Converter Functional Block Diagram

APPLICATIONS

RGB Monitor

The analog component output of the 5200 module can be used to feed an RGB monitor to view the 601 serial digital source input signal to the module. This application is shown in the block diagram below.

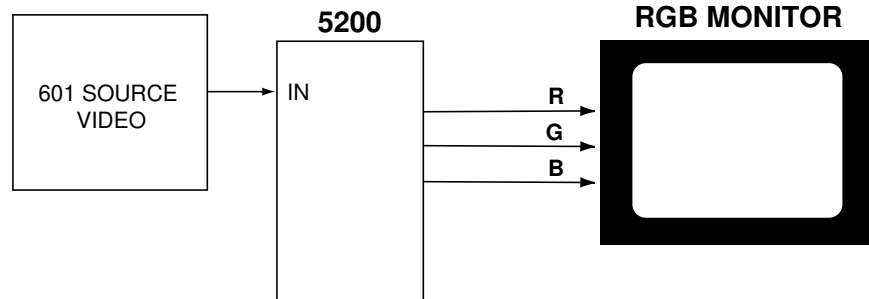

RGB Monitor Application

Composite Encoder for Transmission

The 5200 can convert the output of a digital master control switcher to composite video to feed a transmitter. The information can be monitored on a composite monitor and by the System Control module and read from the remote Avenue remote control options.

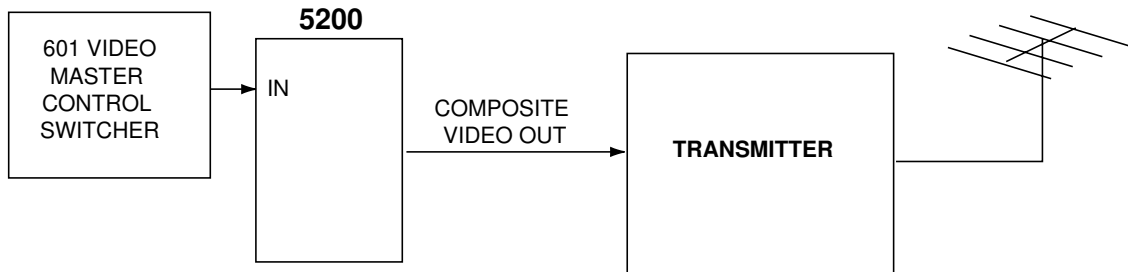

Serial Digital to Composite Encoder for Transmission Application

Serial Digital to RGB Component with Re-timing

The 5200 with the optional 5210 Genlock/Frame Synchronizer installed allows output signals to be timed independently of the input. This provides timing options for applications requiring timing to a house reference, such as the application shown below.

In this case, a serial digital signal is converted to analog component by the 5200 and feeds a character generator. The input signal to the character generator needs to be adjusted in terms of V or H timing positioning to match the house reference feeding all devices.

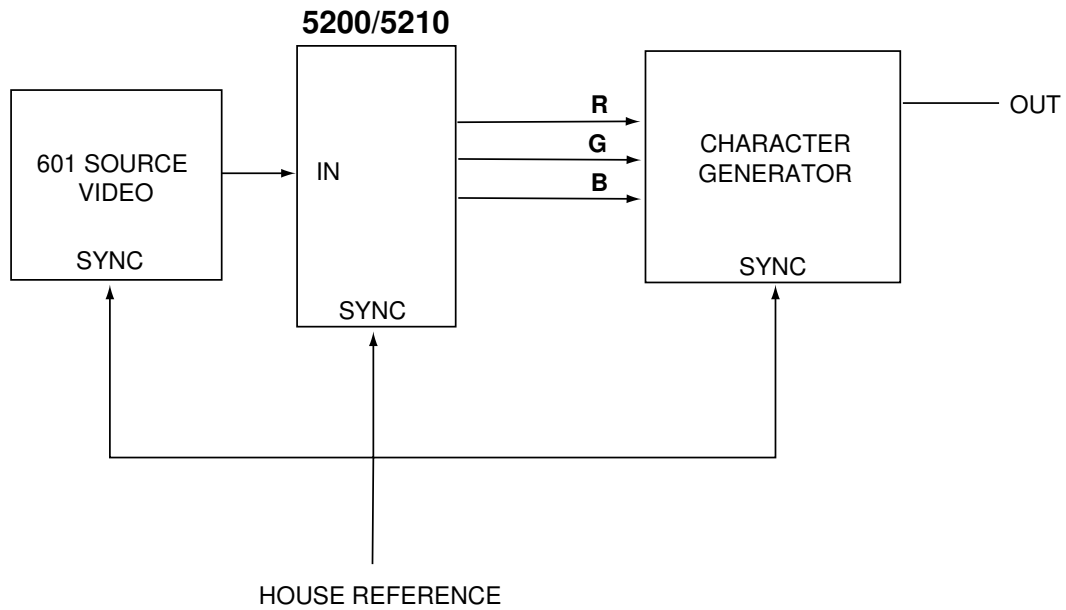

Serial Digital to RGB Component with Re-timing Application

INSTALLATION

5210 Genlock Option

Plug the 5210 Genlock submodule onto the two 40-pin connectors on the component side of the 5200 Video DAC module. The connectors are keyed such that the submodule can only be installed to match the connector keying.

5200 DAC Module

Plug the 5200 module into any slot in the 1 RU or 3 RU frame and install the plastic overlay provided onto the corresponding group of rear BNC connectors associated with the module location. Note that the plastic overlay has an optional adhesive backing for securing it to the frame. Use of the adhesive backing is only necessary if you would like the location to be permanent and is not recommended if you need to change module locations.

This module may be hot-swapped (inserted or removed) without powering down or disturbing performance of the other modules in the system.

CABLING

Refer to the 3 RU and 1 RU backplane diagrams of the module on the next page for cabling instructions. Note that unless stated otherwise, the 1 RU cabling explanations are identical to those given in the 3 RU diagram.

3 RU Backplane

For Component or RGB output operation: Connect one set of output destinations to BNCs: **Y/G1, Cr/R 1, and Cb/B 1.** Connect the other output destinations to BNCs: **Y/G2, Cr/R 2 and Cb/B 2.**

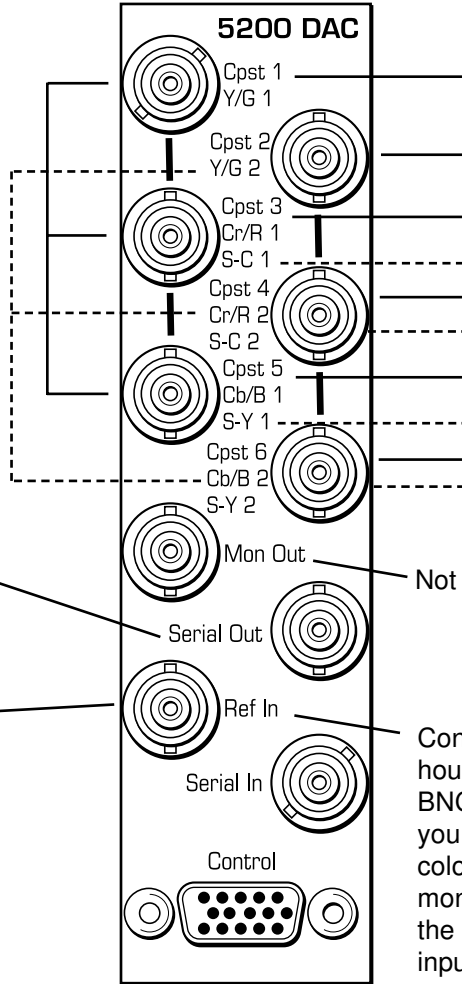

For Composite output operation: Connect BNCs **Cpst 1, Cpst 2, Cpst 3, Cpst 4, Cpst 5, and Cpst 6** to analog composite destinations.

For S-Video output operation: Connect one set of Y/C outputs to BNCs **S-C 1 and S-Y 1.** Connect the other set to BNCs **S-C 2 and S-Y 2.**

Connect a cable from the **Serial Out** BNC to loop-through to another digital video device if desired.

Connect the serial digital signal to be converted to the **Serial In** BNC.

Not used.

Connect a sync input from the house reference to the **Ref In** BNC if using the 5210. Or if you want to lock the composite color field sequence of the monitor output. Alternately, use the master timing reference input on the frame.

1 RU Backplane

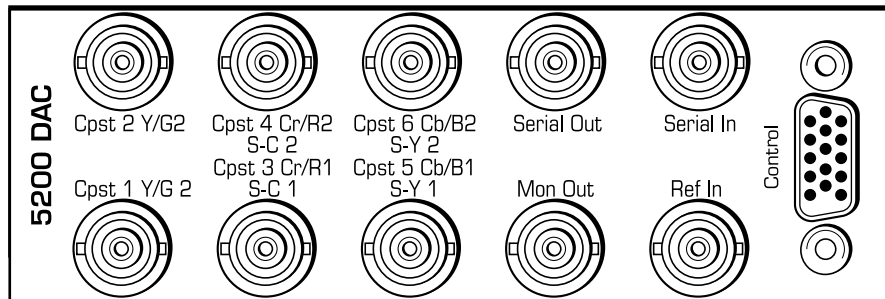

MODULE CONFIGURATION AND CONTROL

The configuration parameters for each Avenue module must be selected after installation. This can be done remotely using one of the Avenue remote control options or locally using the module front panel controls. Each module has a **REMOTE/LOCAL** switch on the front edge of the circuit board which must first be set to the control mode you will be using.

The configuration parameter choices for the module will differ between **Remote** and **Local** modes. In **Remote** mode, the choices are made through software and allow more selections. The **5200 Parameter Table** on the following page summarizes and compares the various configuration parameters that can be set remotely or locally and the default/factory settings.

If you are not using a remote control option, the module parameters must be configured from the front panel switches. Parameters that have no front panel control will be set to a default value. The **Local** switches are illustrated in the **Front Panel Controls and Indicators** section following the **5200 Parameter Table**.

Avenue module parameters can be configured and controlled remotely from one or both of the remote control options, the Avenue Touch Screen or the Avenue PC Application. Once the module parameters have been set remotely, the information is stored on the module CPU. This allows the module be moved to a different cell in the frame at your discretion without losing the stored information. Remote configuration will override whatever the switch settings are on the front edge of the module.

For setting the parameters remotely using the Avenue PC option, refer to the **Avenue PC Remote Configuration** section of this document.

For setting the parameters remotely using the Avenue Touch Screen option, refer to the **Avenue Touch Screen Remote Configuration** section of this data pack following Avenue PC.

5200 Parameter Table

CONTROL	LOCAL	REMOTE	DEFAULT	USER LEVEL
Format	Switch 1, 2 and 3, (See Format Table on following page.)	Composite SMPTE Beta RGB MII S-Video	Composite	User 3
Setup	Switch 4: On Off	On Off	On	User 3
Reference Source	External	Digital In Ext Reference Master Ref	Digital In	User 3
Color Lock	Normal	2 Field Normal Field 3 Field 5 Field 7	2 Field	User 3
Max Cable	300 meters	0 – 350 meters	0 meters	User 3
Test Signal Enable	N/A	On Off	Off	User 2
Test Signal Type	N/A	Modulated Ramp 75% Bars 100% Bars	75% Bars	User 2
Vertical Blanking	Switch 5: On (Narrow) Off (Wide)	Lines 6 – 25	Line 20	User 3
EDH Insert	Switch 6: On Off	On Off	On	User 3
Fine Phase	N/A	+/- 70 nsec	0 nsec	User 3
Horizontal Timing	N/A	+/- 1716 clocks	0 clocks	User 3
Vertical Timing	N/A	+/- 525 lines	0 lines	User 3
Gain	N/A	0 – 120%	100%	User 1
Chroma	N/A	0 – 110%	100%	User 1
Hue (NTSC)	N/A	+/- 45 degrees	0 degrees	User 1
Pedestal	N/A	+/- 10 IRE	0 IRE	User 1
Y/G Gain	N/A	80 – 120%	100%	User 1
Cr/R Gain	N/A	80 – 120%	100%	User 1
Cb/B Gain	N/A	80 – 120%	100%	User 1
Memory Registers	N/A	1 – 5	Last Saved	User 3

Front Panel Controls and Indicators

Each front edge indicator and switch setting is shown in the diagram below:

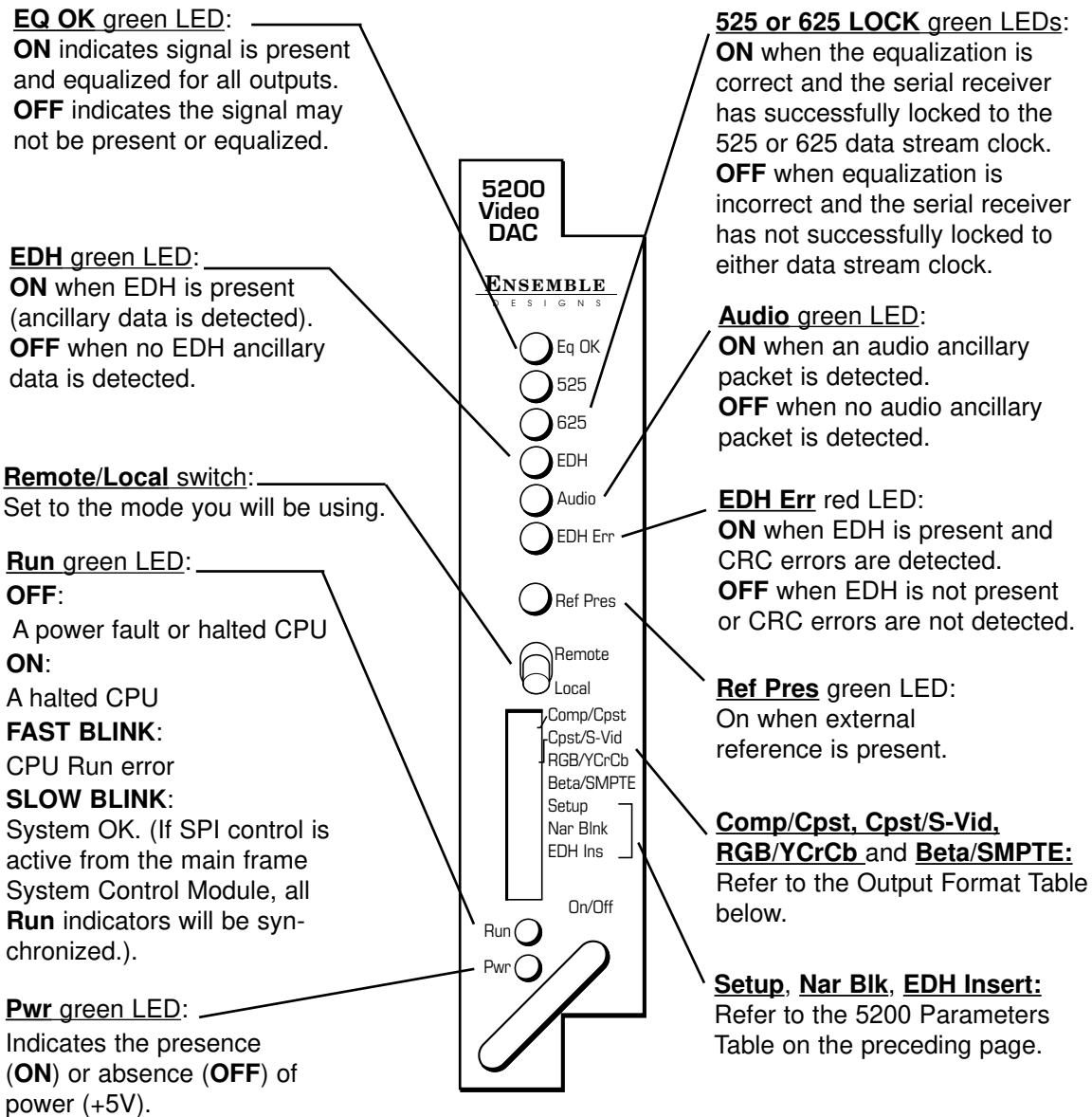

Output Format Table

FORMAT	SWITCH 1: Comp/Cpst	SWITCH 2: Cpst/S-Vid	SWITCH 3: RGB/YCrCb	SWITCH 4: Beta/SMPTE
NTSC/PAL	Cpst (see Note)	Cspt	N/A	N/A
S-Video	Cpst (see Note)	S-Vid	N/A	N/A
RGB	Comp	N/A	RGB	N/A
Beta YCrCb	Comp	N/A	YCrCb	Beta
SMPTE YCrCb	Comp	N/A	YCrCb	SMPTE
MII	Remote mode only, not accessible through Local mode.			

NOTE: Detection of Composite 525 or 625 is automatic.

Avenue PC Remote Configuration

The Avenue PC remote control menus for this module are illustrated and explained below. Refer to the 5200 Parameter Table for a summary of available parameters that can be set remotely through the menus illustrated. For more information on using Avenue PC, refer to the Avenue PC Control Application Software data pack that came with the option.

Parameter fields that are grayed out can indicate one of the following conditions:

- An option is not installed.
- The function is not active.
- The User Level set with Avenue PC is not accessible from the current User Level.

5200 Avenue PC Menus

In the **Format** menu shown below, set the following parameters:

- **Format** – set the desired format for the module outputs.
- **Setup** – enable or disable for setup on the output signal.
- **Ref Source** – choose the reference source for the module.
- **Color Lock** – determines where the ScH color field sequence will occur on the output signal in relation to the input. This setting applies to **Composite** signals only. Set to **2 Field**, the output ScH phase may be in or out of phase with the input (arbitrary). Set to **4 Field Norm**, the output ScH phase will match the input. Set to **4 Field Invert**, the output will be out of phase with the input.

The following status items are reported in the **Format** menu:

- **Reference** – shows status of reference input to module.
- **Option** – indicates the presence of the 5210 option installed on the module.

Format	Serial	Output	Timing	Proc	CAV Gain	Memory
Format						
Setup						
Ref Source						
Reference						
Color Lock						
Option						

In the **Serial** menu shown below, the following parameters can be set:

- **Max Cable** – set the maximum cable length to be equalized.

Module information for the following items is provided in the **Serial** menu:

- **Equalizer** – indicates if input is present and equalized for all outputs.
- **PLL Lock** – indicates equalization is correct and the serial receiver has successfully locked to the data stream clock.
- **Cable Length** – indicates length of cable being equalized.
- **EDH** – indicates if EDH is present.
- **Audio** – indicates presence of audio ancillary data.
- **EDH Error** – indicates presence of CRC errors in EDH.

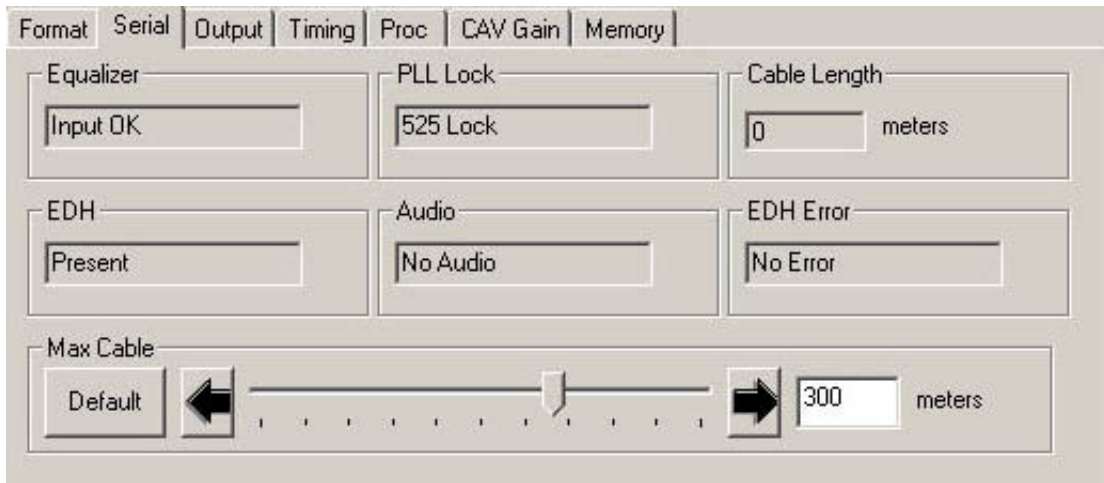

Set the **Output** menu items below:

- **Test On/Off** – turns the test signal on or off.
- **Test Signal** – select the type of test signal; 75% Bars, 100% Bars, or Ramp.
- **Vert Blanking** – set blanking to end on line 10 (narrow) or line 20 (wide).
- **EDH Insert** – set to **On** or **Off** to enable or disable EDH insertion into the Serial output video.

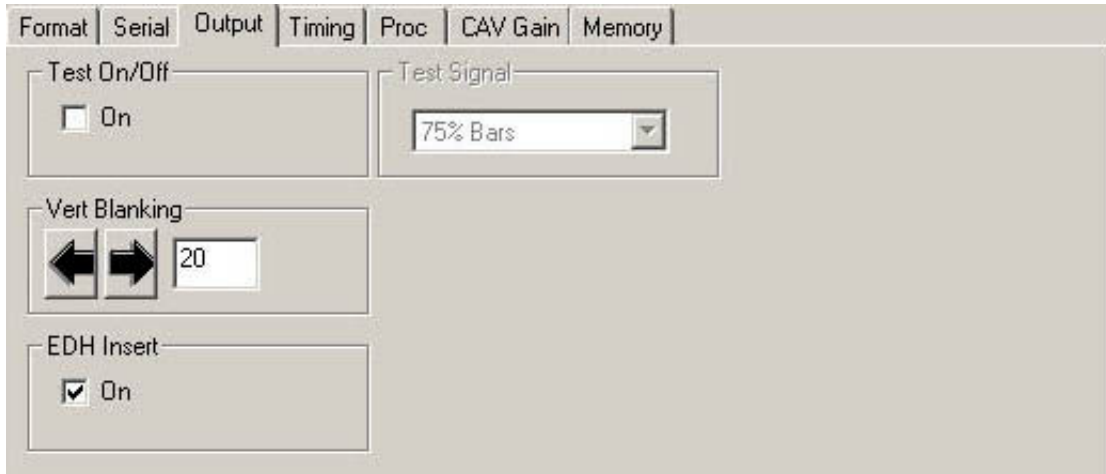

The **Timing** menu below is used when the optional 5210 Genlock submodule is installed on the 5200. Set the timing selections as follows, in the order given:

- **Vert Timing** – set the vertical timing to a typical setting of 0 lines.
- **Hor Timing** – adjust the horizontal timing of the output signal to place the leading edge of sync coincident with the other sources.
- **Fine Phase** – adjust for proper ScH phase with respect to the other sources.
NOTE: If Fine Phase will not adjust properly, readjust the horizontal phase by up to ± 2 clocks until the Fine Phase falls into place.

The number of lines of delay will be reported in the **Delay** window.

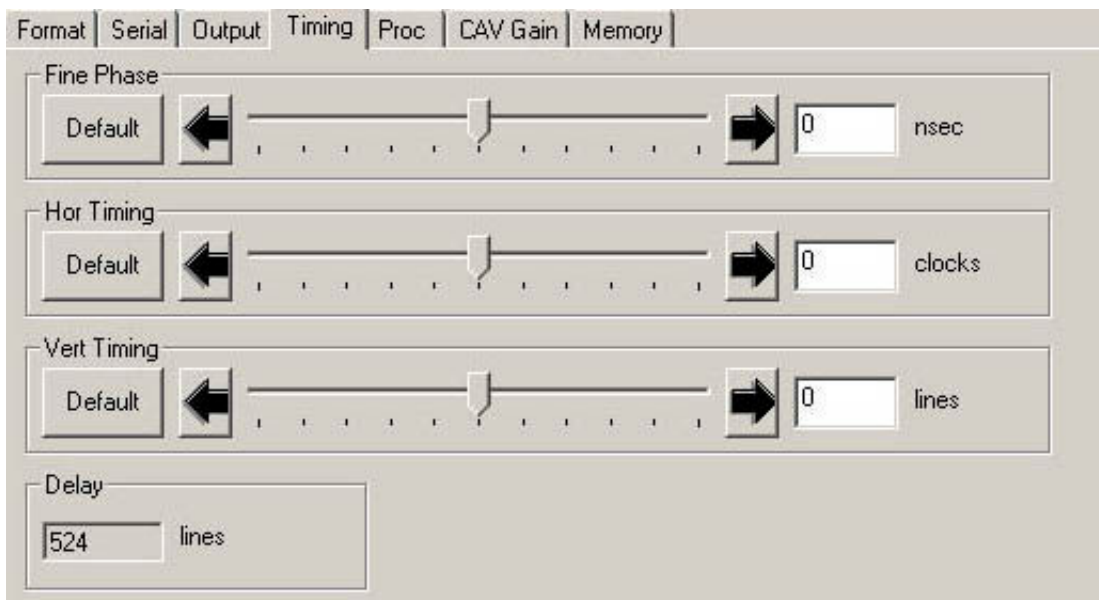

The **Proc** menu below allows adjustment of the following analog composite video parameters:

- **Gain** – adjusts the composite output gain.
- **Chroma** – adjusts the amount of chroma gain on the output.
- **Hue (NTSC)** – adjusts the hue of an NTSC composite output signal.
- **Pedestal** – adjusts the pedestal level of the output signal.
- **ScH Phase** –

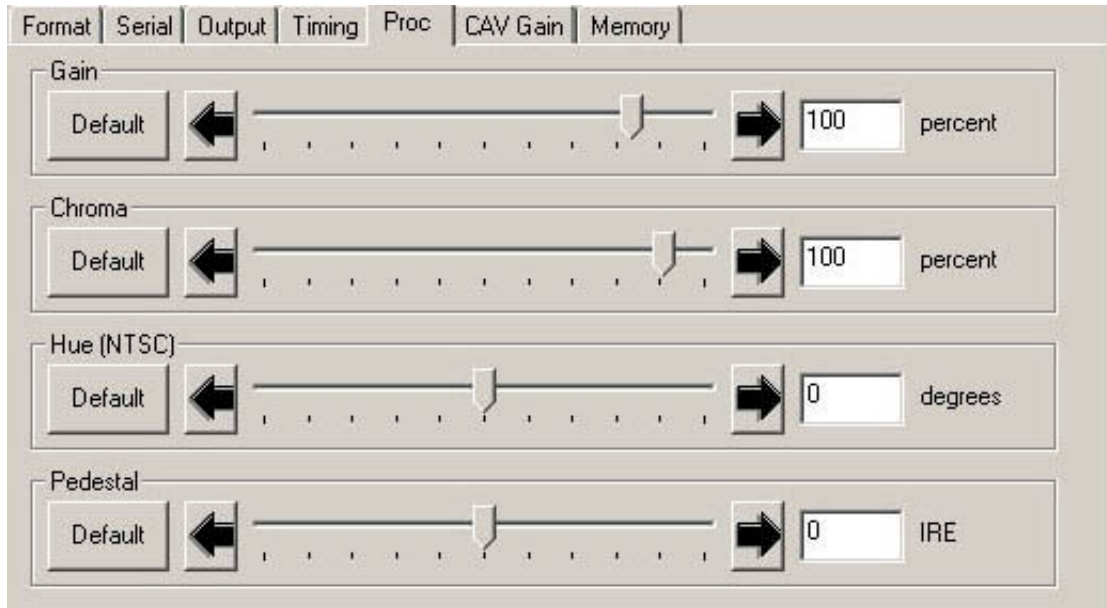

The **CAV Gain** menu below allows adjustment of the following analog component output video parameters:

- **Y/G Gain** - adjusts the output gain of the Y/G channel.
- **Cr/R Gain** - adjusts the output gain of the Cr/R channel.
- **Cb/B Gain** - adjusts the output gain of the Cb/B channel.

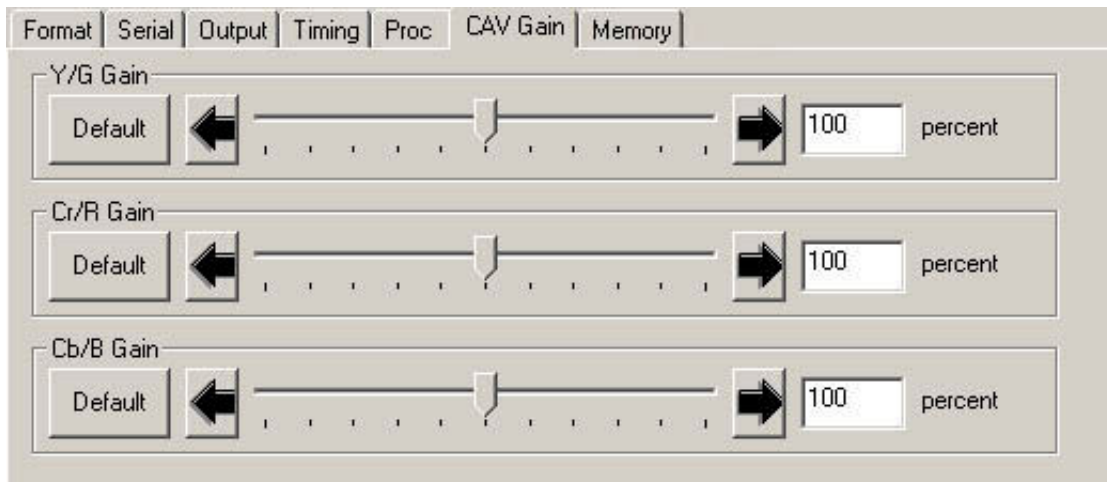

The **Memory** menu allows you to save overall module setups to five memory registers as follows:

- Select **Save**, then one of the five memory registers **Reg 1 – 5**. The box will turn green. The entire module setup is now saved in the selected register.
- To recall a register, select the register box. If there is information saved, the box will turn green. The saved setup will now be loaded to the module. Up to five different module setups can be saved and recalled using the individual registers.

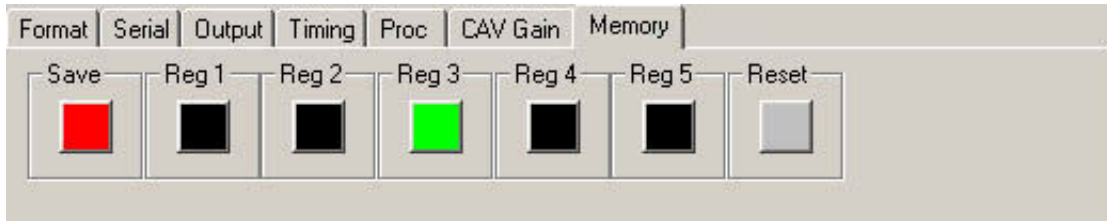

Avenue Touch Screen Remote Configuration

Avenue Touch Screen remote control menus for this module are illustrated and explained below. Refer to the 5200 Parameter Table for a summary of available parameters that can be set remotely through the menus illustrated. For more information on using Avenue Touch Screen, refer to the Avenue Touch Screen data pack that came with the option.

Parameter fields that are grayed out can indicate one of the following conditions:

- An option is not installed.
- The function is not active.
- The User Level set with Avenue PC is not accessible from the current User Level.

5200 Avenue Touch Screen Menus

In the **Format** menu shown below, set the following parameters:

- **Format** – set the desired format for the module outputs.
- **Setup** – enable or disable for setup on the output signal.
- **Ref Source** – choose the reference source for the module.
- **Color Lock** – determines where the ScH color field sequence will occur on the output signal in relation to the input. This setting applies to **Composite** signals only. Set to **2 Field**, the output ScH phase may be in or out of phase with the input (arbitrary). Set to **4 Field Norm**, the output ScH phase will match the input. Set to **4 Field Invert**, the output will be out of phase with the input.

The following status items are reported in the **Format** menu:

- **Reference** – shows status of reference input to module.
- **Option** – indicates the presence of the 5210 option installed on the module.

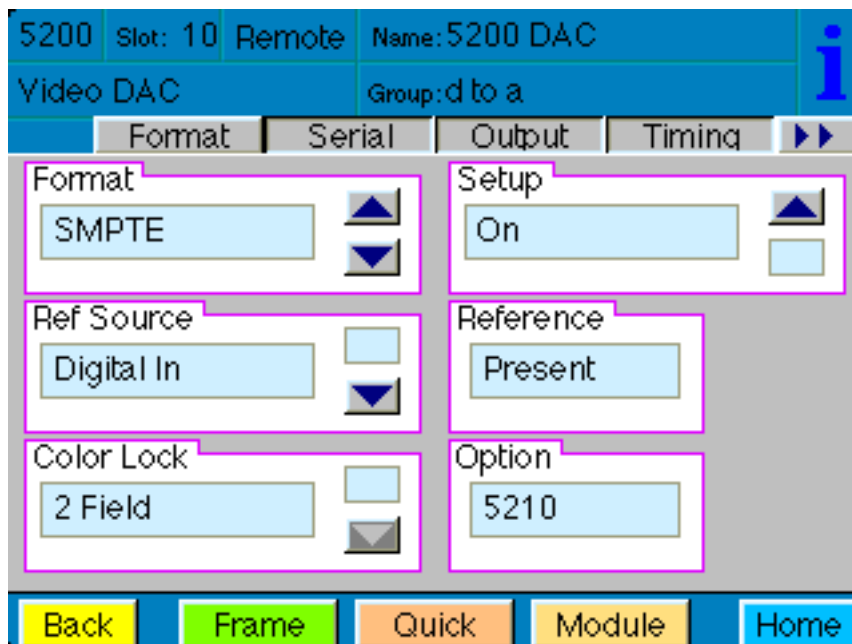

In the **Serial** menu shown below, the following parameters can be set:

- **Max Cable** – set the maximum cable length to be equalized.

Module information for the following items is provided in the **Serial** menu:

- **Equalizer** – indicates if input is present and equalized for all outputs.
- **PLL Lock** – indicates equalization is correct and the serial receiver has successfully locked to the data stream clock.
- **Cable Length** – indicates length of cable being equalized.
- **EDH** – indicates if EDH is present.
- **Audio** – indicates presence of audio ancillary data.
- **EDH Error** – indicates presence of CRC errors in EDH.

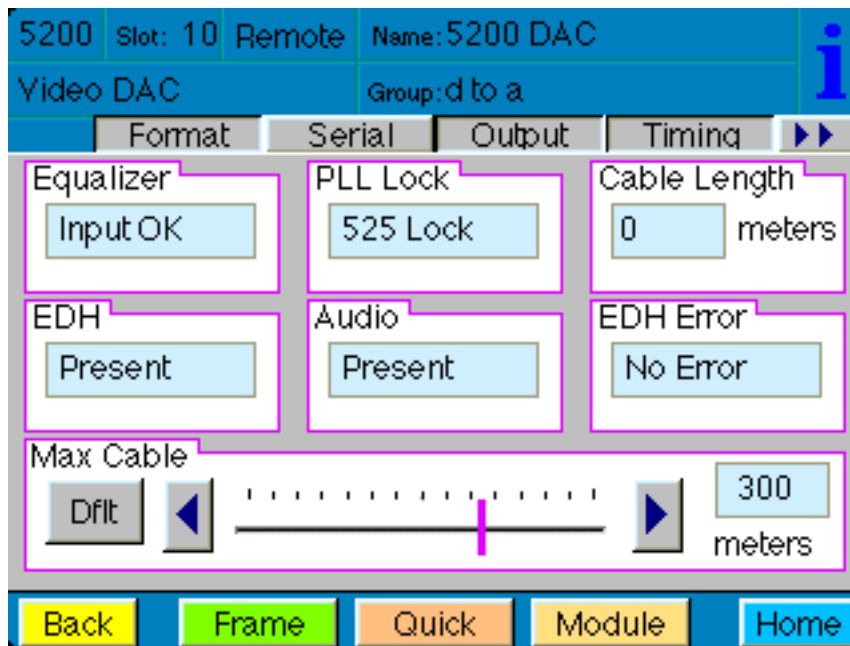

Set the **Output** menu items below:

- **Test On/Off** – turns the test signal on or off.
- **Test Signal** – select the type of test signal; 75% Bars, 100% Bars, or Ramp.
- **Vert Blanking** – set blanking to end on line 10 (narrow) or line 20 (wide).
- **EDH Insert** – set to **On** or **Off** to enable or disable EDH insertion into the Serial output video.

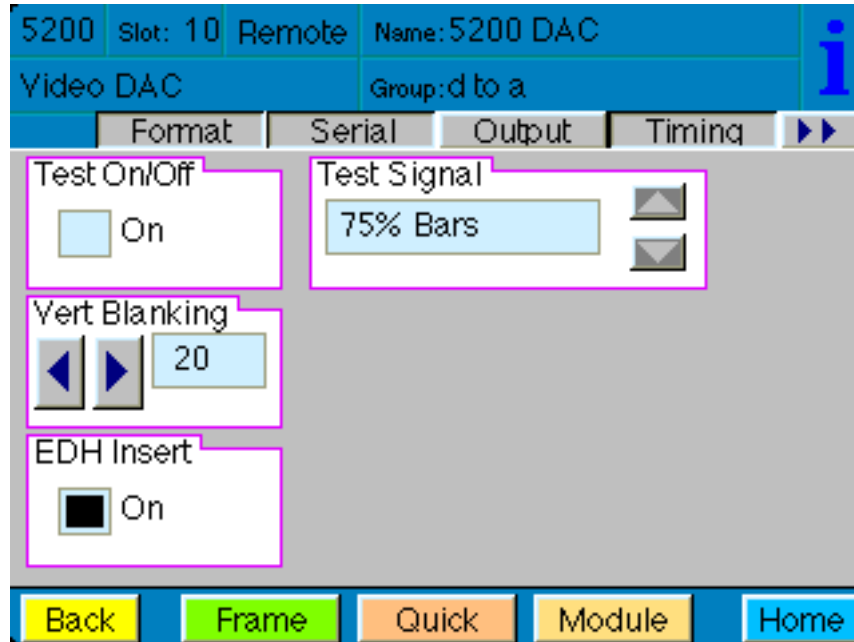

The **Timing** menu below is used when the optional 5210 Genlock submodule is installed on the 5200. Set the timing selections as follows, in the order given:

- **Vert Timing** – set the vertical timing to a typical setting of 0 lines.
 - **Hor Timing** – adjust the horizontal timing of the output signal to place the leading edge of sync coincident with the other sources.
 - **Fine Phase** – adjust for proper ScH phase with respect to the other sources.
- NOTE:** If Fine Phase will not adjust properly, readjust the horizontal phase by up to ± 2 clocks until the Fine Phase falls into place.

The number of lines of delay will be reported in the **Delay** window.

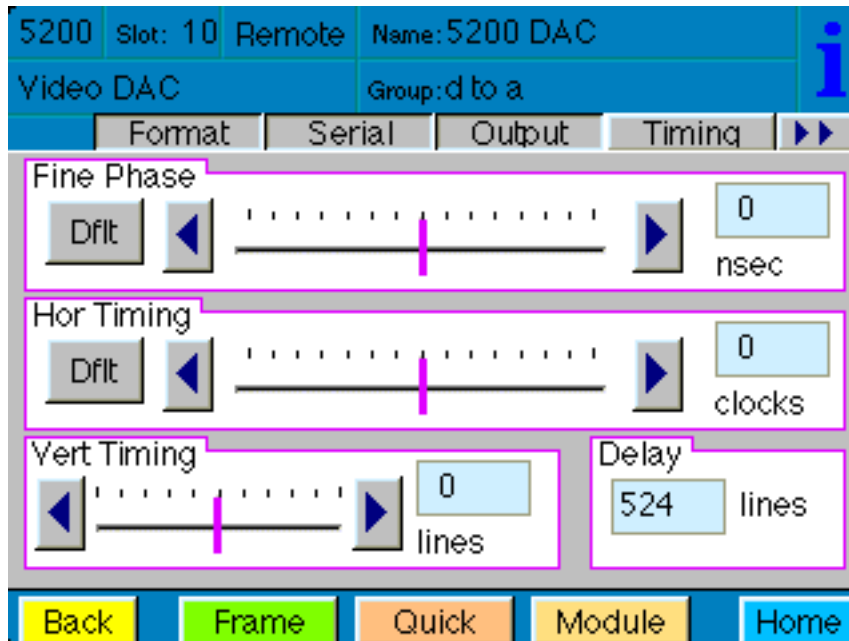

The **Proc** menu below allows adjustment of the following analog composite video parameters:

- **Gain** – adjusts the composite output gain.
- **Chroma** – adjusts the amount of chroma gain on the output.
- **Hue** – adjusts the hue of an NTSC composite output signal.
- **Pedestal** – adjusts the pedestal level of the output signal.

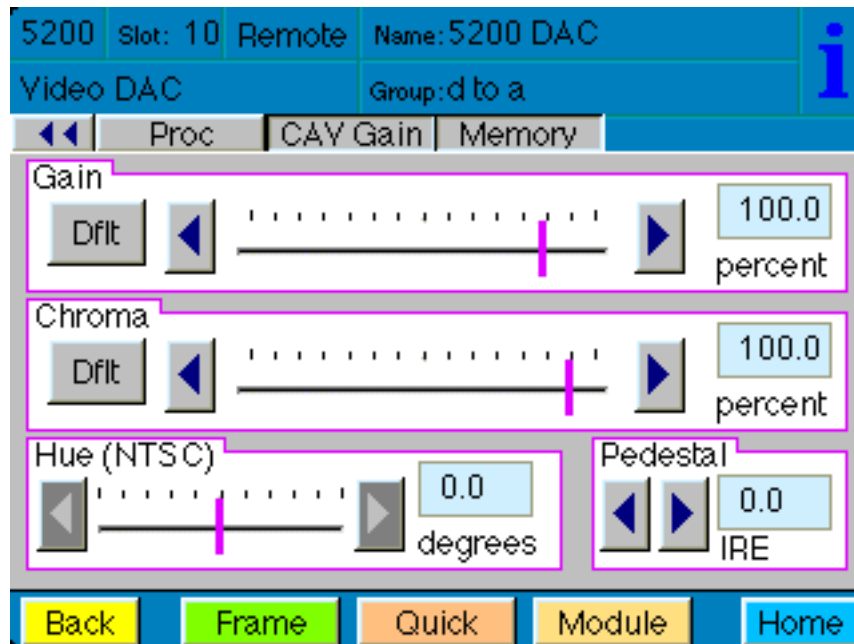

The **CAV Gain** menu below allows adjustment of the following analog component output video parameters:

- **Y/G Gain** - adjusts the output gain of the Y/G channel.
- **Cr/R Gain** - adjusts the output gain of the Cr/R channel.
- **Cb/B Gain** - adjusts the output gain of the Cb/B channel.

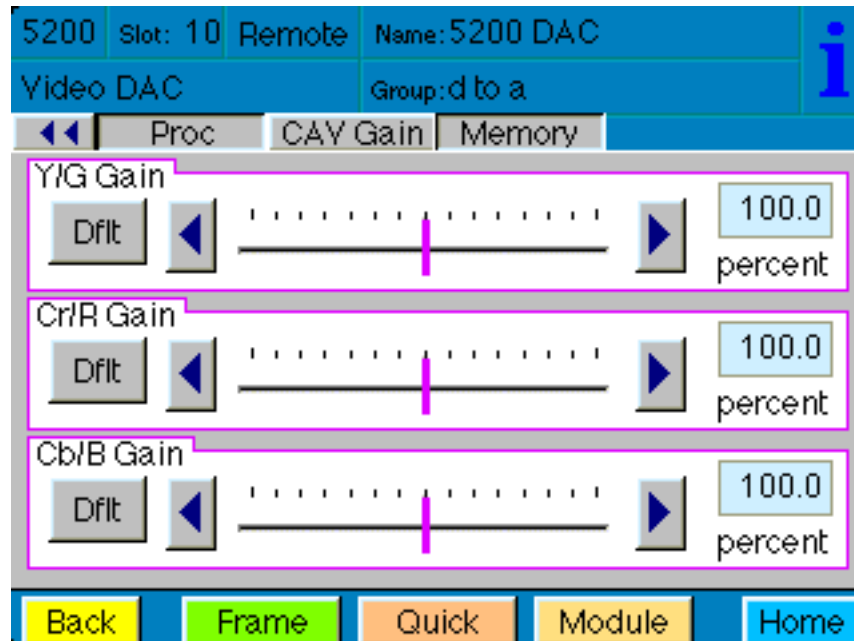

The **Memory** menu allows you to save overall module setups to five memory registers as follows:

- Select **Save**, then one of the five memory registers **Reg 1 – 5**. The box will turn green. The entire module setup is now saved in the selected register.
- To recall a register, select the register box. If there is information saved, the box will turn green. The saved setup will now be loaded to the module. Up to five different module setups can be saved and recalled using the individual registers.

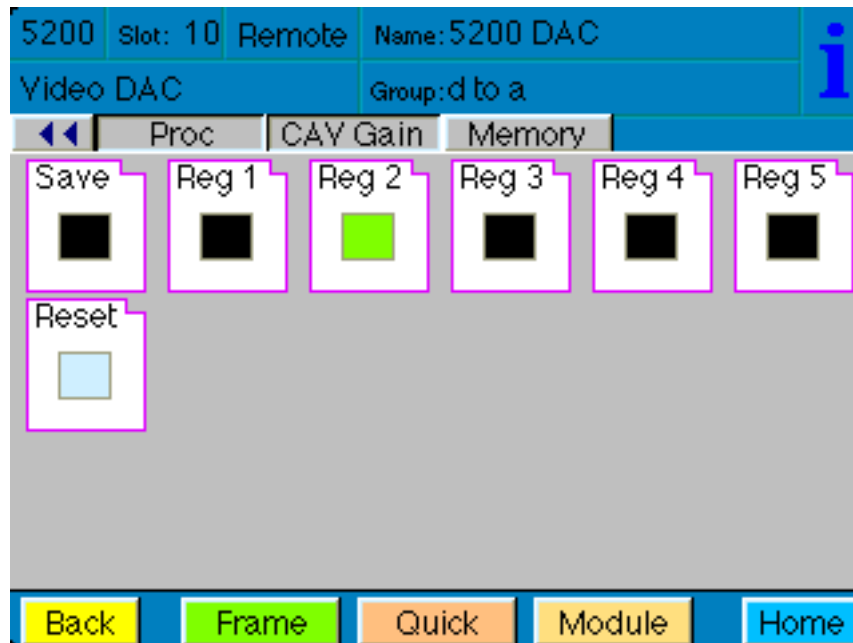

TROUBLESHOOTING

To aid in troubleshooting, the signal equalization and presence, 525/625 Lock, EDH errors, power and CPU status can be easily monitored from the front panel of this module using the indicators explained in the previous section.

If using the **Remote** mode, the following status items can be monitored using the Avenue Touch Screen Control Panel or PC Application:

- Equalization (cable length)
- 525/625 Lock
- EDH Errors
- Audio Presence
- Power status
- Slot ID, Software Version and Board Revision

Refer to the overall troubleshooting tips given below for the module:

No status lights are lit on front panel:

- Check that frame power is present (green LED{s} on frame power supplies).
- Check that module is firmly seated in frame. Try removing it and plugging it in again.

Can't control module:

- Check status of CPU **Run** green LED. Should be blinking slowly and in unison with other modules if System module is present. If not, try removing it and plugging it in again.
- System module may not be working properly if installed.

No signal out of module:

- Check status of EQ OK green LED. Should be lit. If not, check the input signal for presence and quality.
- Check cabling to input of module.
- Check remote cable equalization by switching the module to **Local** using the front panel switch and see if the EQ OK LED comes on.

EDH Error detected:

- Check cable connection at source and input to module
- Check integrity of signal at source

You may also refer to the technical support section of the Ensemble web site for the latest information on your equipment at the URLs below:

<http://www.ensembledesigns.com/support>

SOFTWARE UPDATING

Software upgrades for each module can be downloaded remotely if the optional System Control module is installed. These can be downloaded onto your PC and then Avenue PC will distribute the update to the individual module. (Refer to the Avenue PC documentation for more information) Periodically updates will be posted on our web site. If you do not have the required System Control Module and Avenue PC, modules can be sent back to the factory for software upgrades.

WARRANTY AND FACTORY SERVICE

Warranty

This Module is covered by a five year limited warranty, as stated in the main Preface of this manual. If you require service (under warranty or not), please contact Ensemble Designs and ask for customer service before you return the unit. This will allow the service technician to provide any other suggestions for identifying the problem and recommend possible solutions.

Factory Service

If you return equipment for repair, please get a Return Material Authorization Number (RMA) from the factory first.

Ship the product and a written description of the problem to:

Ensemble Designs, Inc.

Attention: Customer Service RMA #####

870 Gold Flat Rd.

Nevada City, CA. 95959 USA

(530) 478-1830

Fax: (530) 478-1832

service@endes.com

<http://www.ensembledesigns.com>

Be sure to put your RMA number on the outside of the box.

SPECIFICATIONS**5200/5210 Video DAC****Serial Input**

Number:	One
Signal Type:	Serial Digital (SMPTE 259M)
Impedance:	75 ohm
Return Loss:	>15 dB
Maximum Cable Length:	300 meters

Reference Input

Number:	One external One internal master timing ref
Signal Type:	1V p-p nominal composite video PAL or NTSC
Return Loss:	> 40 dB (applies to ext ref input)

Serial Output

Number:	One
Signal Type:	Serial Digital (SMPTE 259M)
Impedance:	75 ohm
Return Loss:	>15 dB
Output DC:	None (AC coupled)

Analog Output

Number	2 sets Y,Cr,Cb or RGB
Impedance:	75 ohm BNC
Return Loss:	> 40 dB
Output DC:	< ± 50 mV

Composite and Y/C Output (S-Video)

Signal Type:	NTSC, PAL
Frequency Response:	± 0.15 dB to 5 MHz
K Factors:	< 1.0%
SCH Phase Error:	< ± 2 degrees
Differential Phase	1 degree
Differential Gain	1%
Color Field sequence	Locked to selected ref
D to A Resolution	10 bit, 4x oversampled, 12 bit processing, 8:8:8 reconstruction
Signal to Noise	> 61 dB
Delay	5 μ sec

Component Output

Signal Type:	RGB without setup, with or without sync on green, Beta Y,Cr,Cb, SMPTE Y,Cr,Cb
Frequency Response:	± 0.15 dB to 5 MHz
Chroma/Luma Delay Inequality:	± 10 ns
D to A Resolution	10 bit, 4x oversampled
Signal to Noise	> 65 dB
Delay	5 μ sec

General Specifications

Power Consumption:	< 7.0 Watts
Temperature Range:	0 to 40 degrees C ambient
Relative Humidity:	0 to 95% noncondensing
Altitude:	0 to 10,000 ft

Due to ongoing product development, all specifications subject to change.