

# BrightEye 90

## HD Up/Down/Cross Converter and ARC with AES Audio

### Easy To Use

BrightEye 90 is a versatile up/down/cross converter or aspect ratio converter for use with analog and digital video signals. Simply set the BrightEye 90 to output your facility's preferred HD or SD standard. The BrightEye 90 will accommodate whatever input you connect – analog composite, SD SDI or HD SDI. After setting the output standard, BrightEye 90 automatically converts the selected input to the correct standard for your facility. BrightEye 90 will upconvert, downconvert, cross convert, or act as an ARC, as needed. The HDMI, SDI and composite outputs are all extremely high quality, suitable for any part of your signal chain. A special Mirror Flip Output mode can be enabled, causing the output image to be flipped left to right for use with on-camera talent. The built-in frame synchronizer allows you to feed asynchronous signals to the BrightEye 90. An external reference input allows genlock to a house reference. All vertical interval data and closed captioning is faithfully passed.

### Upconverting to High Definition

Feed the analog composite or SD SDI output of a camera to a BrightEye 90 and upconvert to HD. You can take the HDMI and HD SDI signals from the BrightEye 90 into your switcher or projection system. Upconverting existing SD equipment lets you leverage the equipment you already have and operate in the HD domain.

While some cameras may have firewire out, using the video output and upconverting before distribution is preferable since longer cable runs can be achieved and quality is superior. Additionally, the BrightEye 90's reference input allows you to time the upconverted video output for use with a production switcher.

### Downconverting to Standard Definition

BrightEye 90 will downconvert any type of HD signal and provides HDMI, SD SDI and an analog composite outputs suitable for broadcast or monitoring.

### Cross Conversion

It's easy to convert between various HD standards, whether 720p or 1080i. Simply select the output standard you need and connect the input – that's all there is to it.

### Aspect Ratio Conversion

For converting between SD 4:3 and HD 16:9, BrightEye 90 has you covered. Just select the output standard you need and connect the input.

### Audio Processing Made Simple

BrightEye 90 handles both embedded audio and discrete AES digital audio streams. Sixteen channels of embedded audio are supported in BrightEye 90. If the incoming video has embedded audio, the audio will be safely bypassed around the video processing and lipsync will be preserved. Audio mixing is available for two of the four embedded groups of audio. The AES I/O ports can be configured for eight channels of incoming audio or for eight channels of audio output. The audio mixer can be used for AES channels as well. Mixer controls are accessed through BrightEye Mac or PC software.

### Easy Audio Monitoring

Audio monitoring is easy with BrightEye 90's convenient 3.5 mm mini jack. Select the audio channels you want to monitor from the front panel and plug in a headset.

### Front Panel and Software Control

Input selection, gain control, and test pattern controls are provided through the front panel interface. Audio presence LEDs indicate which channels are detected. Controls for crop, letterbox and pillarbox are accessed from the front panel or BrightEye Mac or PC software. Video and audio levels and the audio mixer can be adjusted through BrightEye Mac or PC software.



# BrightEye 90

## HD Up/Down/Cross Converter and ARC with AES Audio

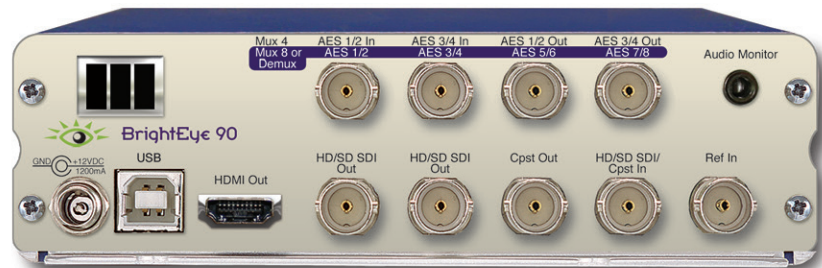
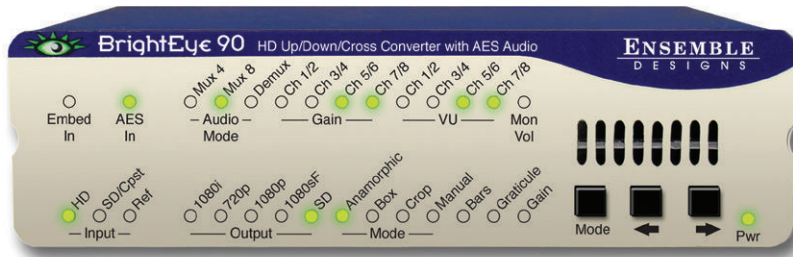

### Features

- Use with cameras and projection systems
- Turn analog camera into digital HD source
- HD and SD digital and analog composite video I/O
- HDMI output
- AES digital audio I/O
- Analog audio monitor output
- Mirror output mode for on-camera talent
- Graticule and Safe Title generator
- Frame sync
- 12 and 16 bit processing
- Passes embedded audio

# BrightEye 90

## HD Up/Down/Cross Converter and ARC with AES Audio

### Analog Video Input

Number	One
Type	Analog Composite PAL or NTSC
Resolution	Digitized at 12 bits
Impedance	75 $\Omega$
Return Loss	>40 dB
Input DC	+/-1 volt DC
Input Hum	<100 mV

### Serial Digital Input

Number	One
Signal Type	270 Mb/s SD Serial Digital (SMPTE 259M or 1.485 Gb/s HD Serial Digital (SMPTE 274M or 296M)
Impedance	75 $\Omega$
Return Loss	>15 dB
Max Cable Length	300 meters for 270 Mb/s 100 meters for 1.485 Gb/s

Automatic Input Cable Equalization

### Reference Input

Number	One
Type	1 V P-P Composite Video, PAL or NTSC or Tri-Level Sync
Impedance	75 $\Omega$
Return Loss	>40 dB

### Analog Video Output

Number	One
Type	Composite PAL or NTSC
Return Loss	>40 dB
Output	DC <100 mV

### Serial Digital Output

Number	Two
Type	HD Serial Digital 1.485 Gb/s SMPTE 274M, 292M or 296M or SD Serial Digital 270 Mb/s SMPTE 259M
Delay	Adjustable from 1 field to 1 frame
Processing	12 and 16 bit
Impedance	75 $\Omega$
Return Loss	>15 dB
Max Cable Length	100 meters for HD 300 meters for SD (Belden 1694A)

### HD Standards Supported

1080i (SMPTE 274M -4,5,6)	50, 59.94 or 60 Hz
720p (SMPTE 296M -1,2,3)	50, 59.94 or 60 Hz
1080p (SMPTE 274M -9,10,11)	23.98, 24, 25 Hz
1080sF (RP211 -14,15,16)	23.98, 24, 25 Hz

### AES/EBU Digital Inputs

Number	Four (total of eight channels) (selectable as inputs or outputs)
Type	AES3id
Connector	Coaxial, 75 $\Omega$
Bit Depth	20 and 24 Bit
Sample Rate	30 KHz to 96 KHz (Sample Rate Converted internally to 48 KHz)
Reference Level	-18 or -20 dBFS (selectable)

### AES/EBU Digital Outputs

Number	Four (total of eight channels) (selectable as inputs or outputs)
Type	AES3id
Connector	Coaxial, 75 $\Omega$
Bit Depth	24 Bit
Sample Rate	48 KHz, synchronous to video output
Reference Level	-18 or -20 dBFS (selectable)

### Embedded Output (In Serial Output)

Group Assign	Two of four groups
Channels	Sixteen passed
Bit Depth	24 Bit

### HDMI Output

Number	One
Connector	HDMI
Type	Follows SDI out

### Audio Monitoring Output

Number	One (Select from sixteen channels)
Connector	3.5 mm stereo mini jack

### General Specifications

Size	5.63" W x 1.65" H x 5.98" D (143 mm x 42 mm x 152 mm) including connectors and flange
Weight	1 lb 8 oz
Power	12 volts, 12 watts (100-230 VAC modular power supply)
Temperature Range	0 to 40° C ambient (all specs met)
Relative Humidity	0 to 95%, non-condensing
Altitude	0 to 10,000 ft.

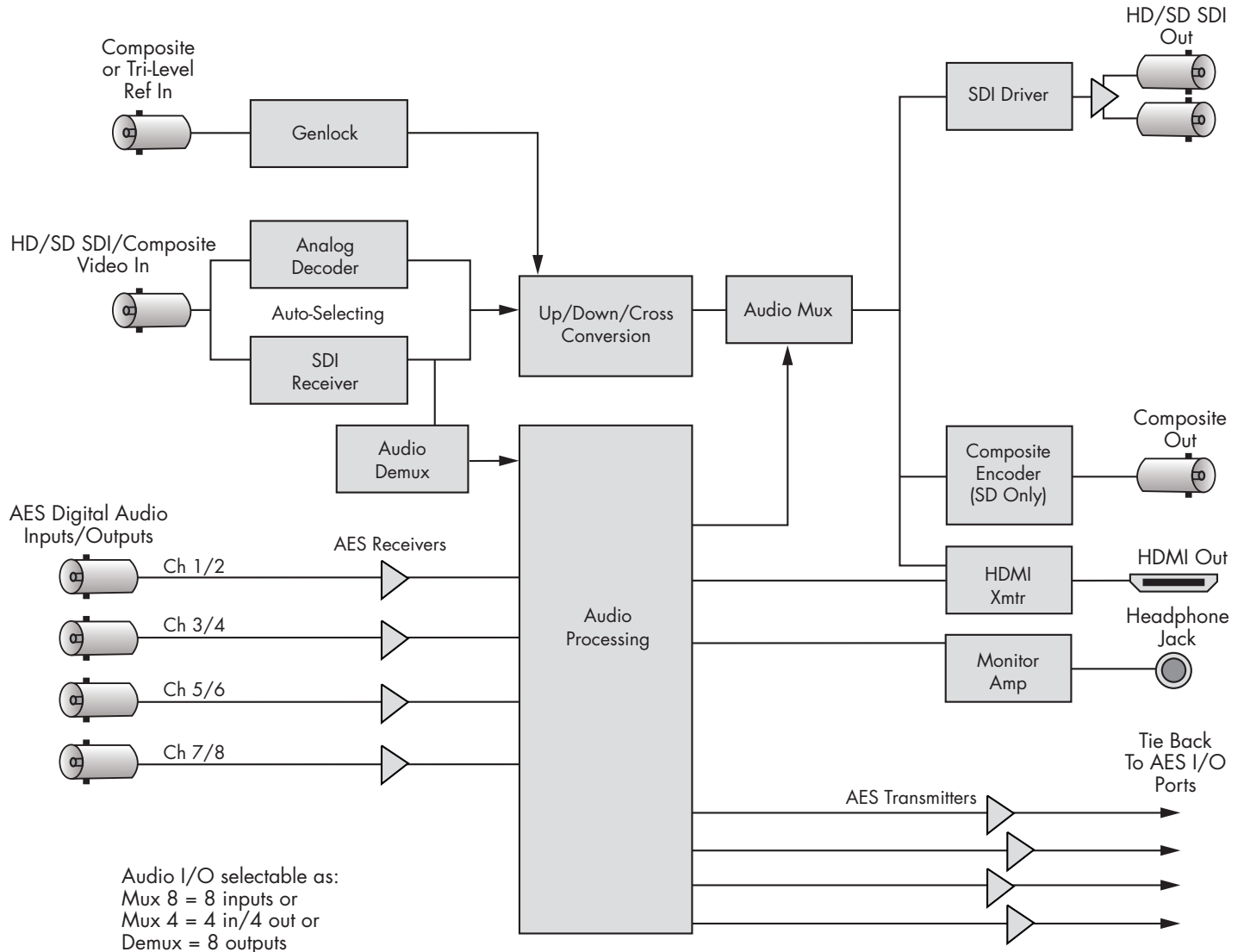

Provides embedded pass through of all 16 audio channels