

# BrightEye 30

## Audio ADC and DAC, Bidirectional

BrightEye 30 is a flexible audio converter that can be a two channel, Bidirectional ADC and DAC, or it can be configured as a four channel converter. Perfect in desktop, post and broadcast applications, 24 bit processing ensures beautiful audio.

As a Bidirectional converter, two channels of analog audio are converted to AES digital audio and at the same time an AES stream is converted to two channels of analog.

Alternately, the unit can be configured as a four channel AES to analog converter or a four channel analog to AES converter.

BrightEye 30 also serves as a sample rate converter. For example, a digital 44.1 KHz signal from a CD player can be fed to the input and a digital AES3id, 48 KHz signal synchronous to the reference input will be output.

Audio mixing, level adjustments, and channel shuffling are accessed through BrightEye Mac or PC software. A variety of audio connectors and adapters are available for integrating BrightEye 30 to any type of system.

A reference input is provided which allows digital outputs to be synchronized to either a PAL or NTSC video signal or AES reference.

### Features

- 2 or 4 channel audio converter
- Analog and digital inputs
- Analog and digital outputs
- Bidirectional ADC/DAC
- Sample rate converter

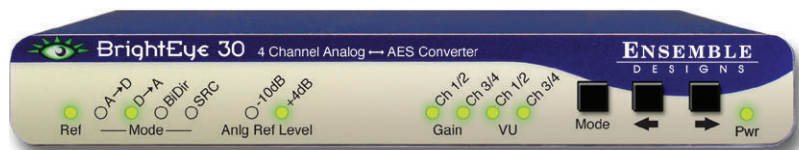

# BrightEye 30

## Audio ADC and DAC, Bidirectional

### Analog Audio Inputs

Number	Four (selectable as inputs or outputs)
Type	Balanced
Impedance	>15K $\Omega$
Maximum Input Level	24 dBu
CMRR	>60 dB, 20 Hz to 10 KHz
Quantization	24 bits, 128 x oversampled
Sample Rate	48 KHz
Reference Level	-10 dBu or +4 dBu
Frequency Response	$\pm 0.1$ dB, 20 Hz to 20 KHz
Crosstalk	<106 dB
Dynamic Range	>106 dB

### AES/EBU Digital Inputs

Number	Two (total of four channels) (selectable as inputs or outputs)
Type	AES3id
Connector	Coaxial, 75 $\Omega$
Bit Depth	20 and 24 Bit
Sample Rate	30 KHz to 96 KHz (Sample Rate Converted internally to 48 KHz)
Reference Level	-18 or -20 dBFS (selectable)
AC-3, Dolby-E	Supported when inputs are synchronous

### Analog Audio Outputs

Number	Four (selectable as inputs or outputs)
Type	Balanced, transformerless
Impedance	30 $\Omega$
Maximum Output Level	24 dBu
Resolution	24 bits, 128 x oversampled
Reference Level	-10 dBu or +4 dBu
Frequency Response	$\pm 0.1$ dB, 20 Hz to 20 KHz
Crosstalk	<106 dB
Dynamic Range	>106 dB

### AES/EBU Digital Outputs

Number	Two (total of four channels) (selectable as inputs or outputs)
Type	AES3id
Connector	Coaxial, 75 $\Omega$
Bit Depth	24 Bit
Sample Rate	48 KHz Synchronous to video output
Reference Level	-18 or -20 dBFS (selectable)

### General Specifications

Size	5.63" W x 0.8" H x 5.98" D (143 mm x 21 mm x 152 mm) including connectors and flange
Weight	1 lb
Power	12 volts, 2 watts (100-230 VAC modular power supply)
Temperature Range	0 to 40° C ambient (all specs met)
Relative Humidity	0 to 95%, non-condensing
Altitude	0 to 10,000 ft.

**BrightEye 30 Block Diagrams on following pages**

# BrightEye 30

## Audio ADC and DAC, Bidirectional

### ADC Mode

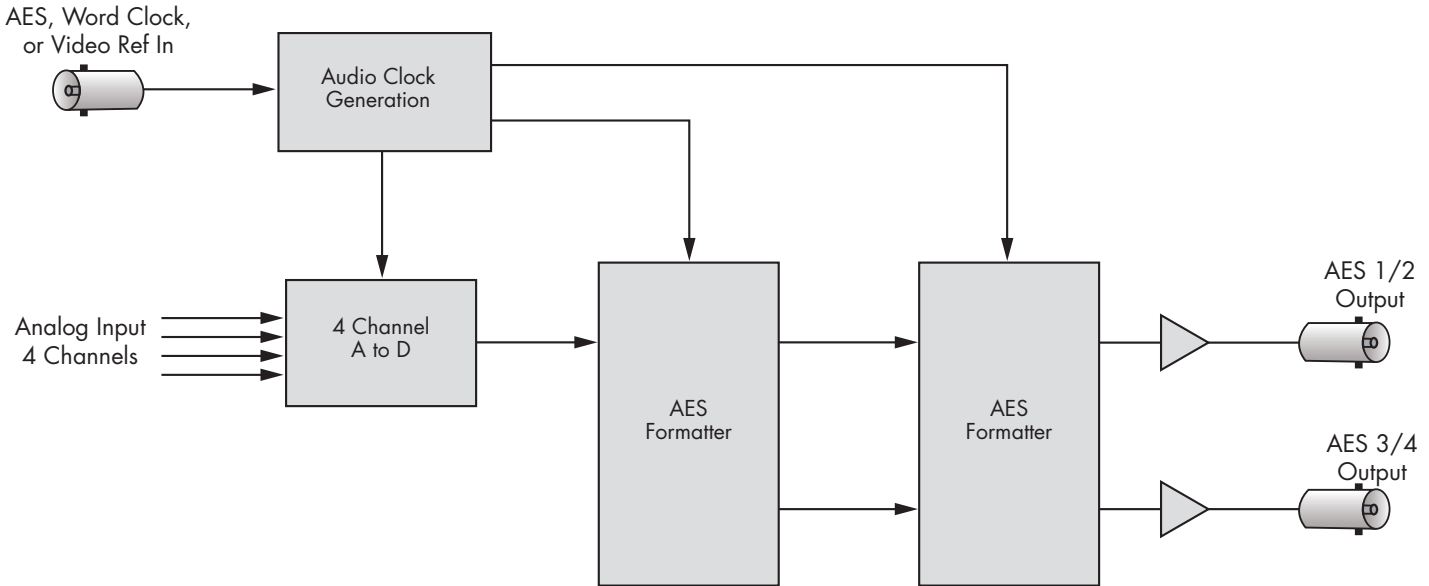

### Bidirectional Mode

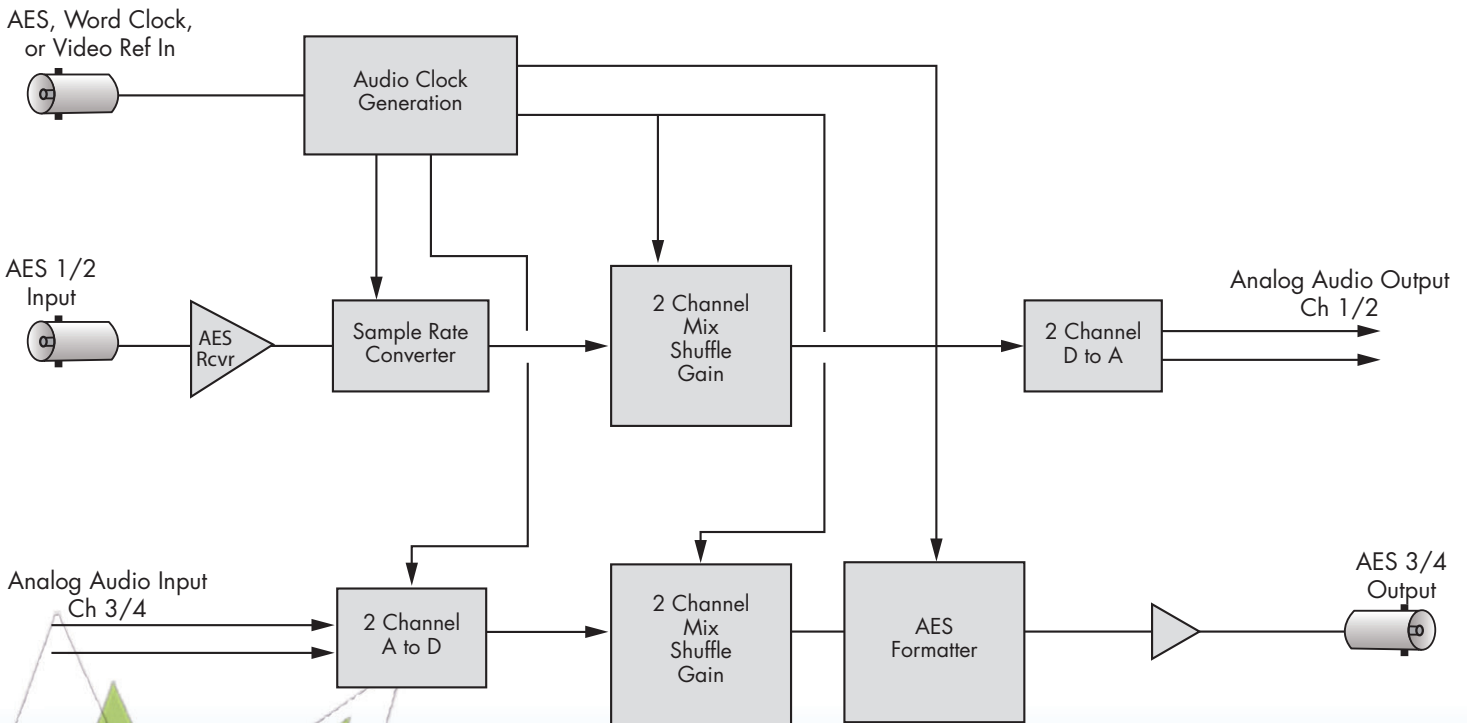

BiDirectional mode provides two independent paths, one is analog to digital conversion, the other is digital to analog.

### DAC Mode

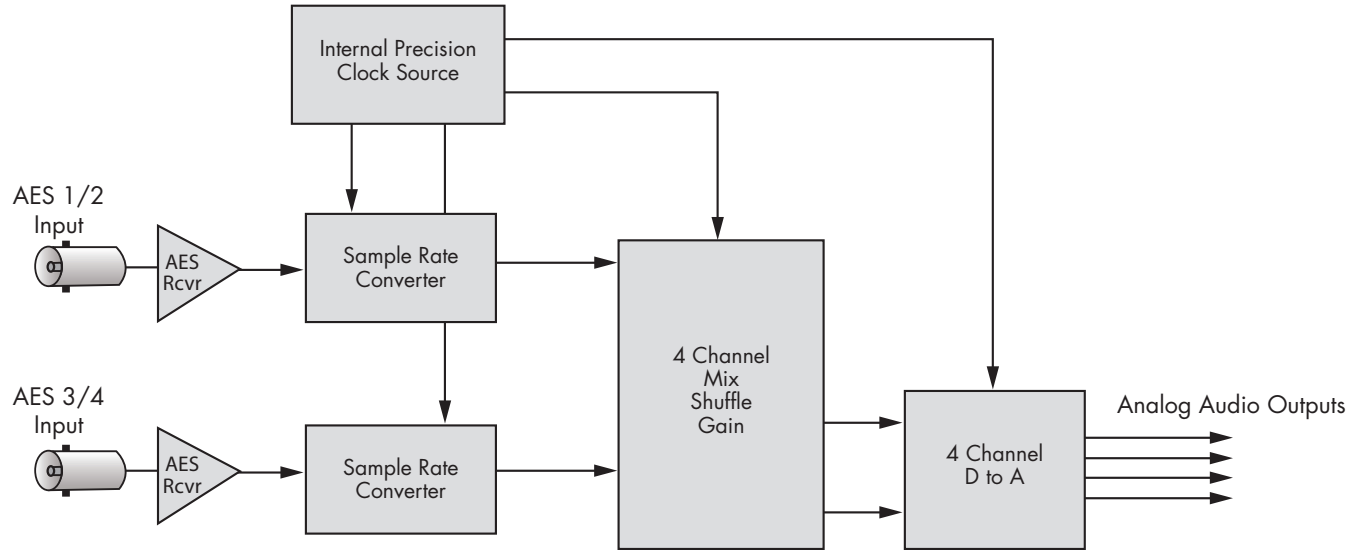

### SRC Mode

