

9600

3G Embedder, Disembedder and Data Inserter

The 9600 module is a sixteen-channel audio embedder or disembedder for 1.5 and 3 Gb/s high definition video signal or 270 Mb/s standard definition signals. Eight AES ports automatically configure as inputs or outputs depending on if the module is configured as mux or demux. Additionally, four channels of analog audio are supported.

Configurable Mux or Demux

When configured as a multiplexer, the 9600 has one serial digital video input and eight AES audio inputs. These eight AES streams are embedded into the video stream. AES inputs are sample rate-converted, allowing the use of asynchronous audio. The output of the module is a digital stream that contains the original video signal and eight AES pairs, or sixteen channels.

When configured as a demultiplexer, audio signals present in the incoming video signal are extracted and delivered as standard AES digital audio streams.

The 9600 includes a full-featured, sixteen-channel audio mixer. The channel swap and shuffle capability allows you to completely rearrange and remix audio channels. It provides precise control over audio level, with up to 12 dB of gain to compensate for low level sources. Delay is adjustable up to one second.

In-Line Shuffler

Because the 9600 has simultaneous disembedding and embedding, it is an in-line processor for embedded audio. It can take embedded content, adjust levels and remap channels, and deliver it to the output as an embedded signal.

Dolby and AC-3

The 9600 can be fitted with Dolby and AC-3 encoding and decoding options. The 7615 decoding option can be fed from either an AES input or an AES stream disembedded from the incoming SDI signal. The resulting discrete surround signals are then selectable as inputs to the sixteen channel mixer/shuffler.

The 7630 Dolby encoder is fed from selected outputs of the sixteen channel mixer/shuffler. The resulting encoded bitstream can be output both on an AES output and embedded into the SDI output.

Additionally, the 9600 fully supports embedding and disembedding of encoded multi-channel bitstreams such as AC-3 and Dolby E.

LevelTrack™ AGC and Compliance Options

The 9670 LevelTrack™ Audio Automatic Gain Control software key can be added as an option. LevelTrack AGC provides control for keeping audio levels consistent in program material.

The 9690 Audio Compliance and Monitoring Software can be added for compliance verification and archiving.

The 9600 can be configured locally or controlled and configured remotely with Avenue Touch Screens, Express Panels, or Avenue PC Software. Alarm generation, configurable user levels, module lockout, and customizable menus are just some of the tools included in the Avenue Control System.

Features

- **Audio embedder or disembedder for 3G, HD or SD signals**
 - **Handles 8 AES streams/16 channels**
 - **Analog audio I/O**
 - **Dolby encoding and decoding options**
 - **Up to one second of delay**
 - **In-line processor for embedded audio**
 - **Audio Automatic Gain Control option**
 - **Built-in audio mixer**
 - **Phase inversion selectable on a channel basis**
 - **Built-in sample rate converters accept asynchronous inputs**
 - **26 bit processing resolution**
 - **Data mux and demux as per SMPTE 337M**
 - **Memory registers**
-

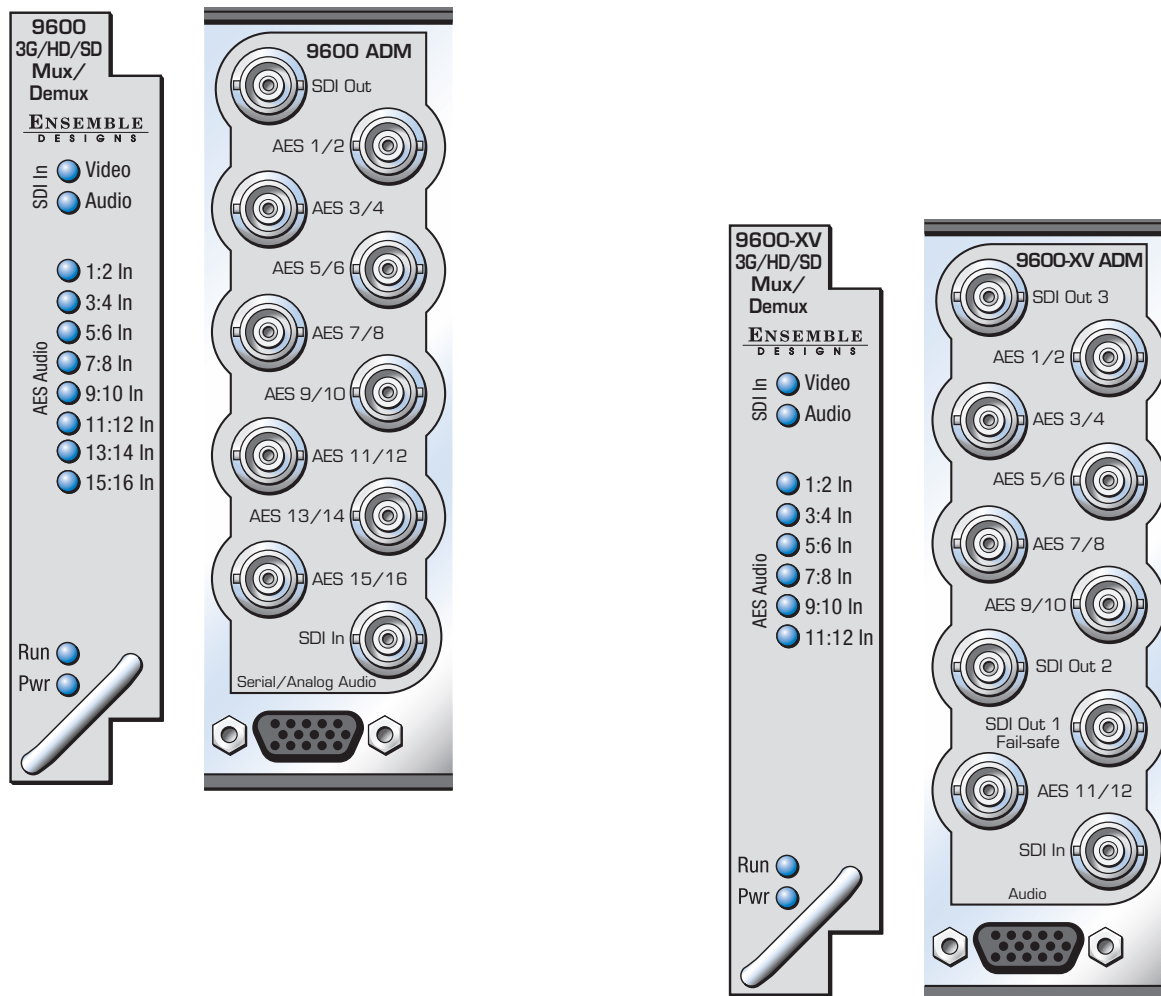

Order Info:

9600	3G/HD/SD Embedder, Disembedder and Data Inserter module
9600-XV	3G/HD/SD Embedder, Disembedder and Data Inserter module with extra video outputs XV configuration provides 12 channels of AES I/O and 3 SDI outputs
7615	Dolby E, Dolby D, AC-3 Decoder sub module and software key option Dolby processing options incur 1 frame of delay
7630	Dolby E Encoder sub module and software key option Dolby processing options incur 1 frame of delay
7635	Dolby D/AC-3 Encoder sub module and software key option Dolby processing options incur 1 frame of delay
9670	LevelTrack Audio Automatic Gain Control software key option
9690	Audio Compliance and Monitoring Software

9600

3G Embedder, Disembedder and Data Inserter

Input

Number	One
Signal Type	HD Serial Digital 1.485 Gb/s, SMPTE 274M, 292M or 296M HD Serial Digital 2.97 Gb/s, SMPTE 424M, 425M SD Serial Digital 270 Mb/s, SMPTE 259M
Impedance	75 Ω
Return Loss	>15 dB DC to 1.5 GHz
Max Cable Length	270 Mb/s 300 meters Belden 1694A 1.485 Gb/s 100 meters Belden 1694A 2.97 Gb/s 70 meters Belden 1694A

Automatic Cable Input Equalization

Standards Supported

1080i 50, 59.94 or 60 Hz, SMPTE 274M -4,5,6
720p 50, 59.94 or 60 Hz, SMPTE 296M -1,2,3
1080p 23.98, 24 or 25 Hz, SMPTE 274M -9,10,11
1080p 50, 59.94 Hz, SMPTE 424M, 425M, Level A
1080sF 23.98, 24 or 25 Hz, RP211 -14,15,16
625i 50, 525i 59.94
Data, SMPTE 337M

Output

Number	One
Signal Type	HD or SD Serial Digital, follows input
Impedance	75 Ω
Return Loss	>15 dB DC to 1.5 GHz

AES/EBU Digital Inputs

Number	Eight (total of sixteen channels) selectable as inputs or outputs
Type	AES3id or data, SMPTE 337
Connector	Coaxial, 75 Ω
Bit Depth	20 and 24 bit
Sample Rate	30 kHz to 100 kHz (sample rate converted internally to 48 kHz)
Crosstalk	<144 dB
Dynamic Range	>144 dB
Reference Level	-18 or -20 dBFS (selectable)

AES/EBU Digital Outputs

Number	Eight (total of sixteen channels) selectable as inputs or outputs
Type	AES3id or data
Connector	Coaxial, 75 Ω
Bit Depth	20 and 24 bit
Sample Rate	48 kHz, synchronous to video output
Reference Level	-18 or -20 dBFS (selectable)

Analog Audio Inputs

Number	Four, selectable as inputs or outputs
Type	Balanced
Connector	15 pin D connector
Impedance	>15K Ω
Maximum Input Level	24 dBu
CMRR	>60 dB, 20 Hz to 10 KHz
Quantization	24 bits, 128 x oversampled
Sample Rate	48 KHz
Reference Level	-10 dBu or +4 dBu
Frequency Response	\pm 0.1 dB, 20 Hz to 20 KHz
Crosstalk	<106 dB
Dynamic Range	>106 dB

Analog Audio Outputs

Number	Four, selectable as inputs or outputs
Type	Balanced, transformerless
Connector	15 pin D
Impedance	30 Ω
Maximum Output Level	24 dBu
Resolution	24 bits, 128 x oversampled
Reference Level	-10 dBu or +4 dBu
Frequency Response	\pm 0.1 dB, 20 Hz to 20 KHz
Crosstalk	<106 dB
Dynamic Range	>106 dB

Dolby Metadata Inputs/Outputs

Signal Type	Dolby metadata, RS-422, RS-485
Number	Four, selectable as inputs or outputs, share with analog audio I/O
Connector	HD-15, balanced

Embedded Output (In SDI Outputs)

Group Assign	Cascade or replace
Channels	Sixteen
Bit Depth	24 Bit

3G Embedder, Disembedder and Data Inserter

General Specifications

Power Consumption	10 watts
Temperature Range	0 to 40°C ambient (all specs met)
Relative Humidity	0 to 95%, noncondensing
Altitude	0 to 10,000 ft

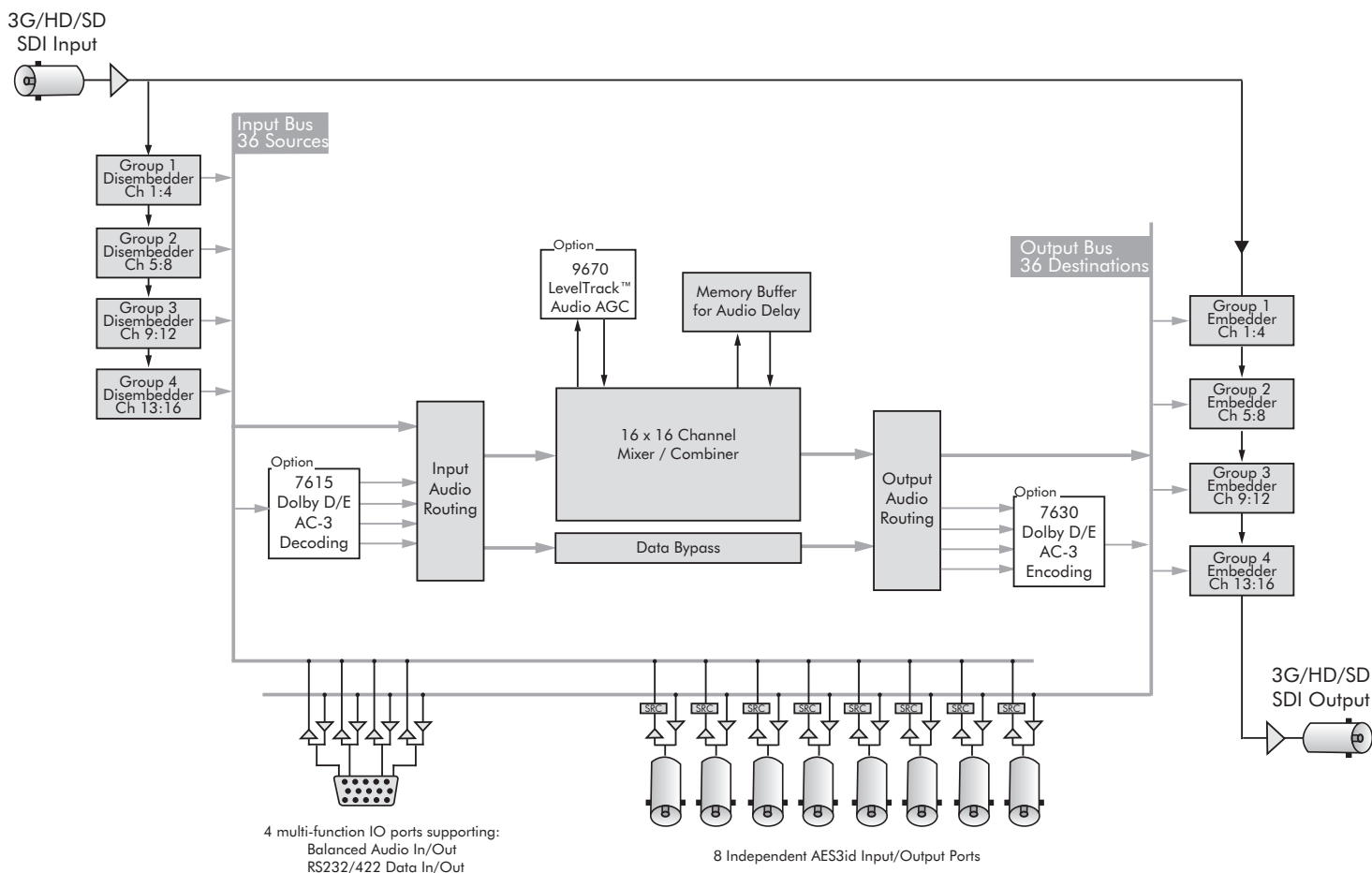

Above, block diagram for the 9600 3G/HD/SD Embedder, Disembedder and Data Inserter module

Alternately, for 12 channels of AES I/O and 3 SDI outputs, order the 9600-XV