

# 7900

## HD Up/Down/Cross Converter

### Do It All With One Module

The 7900 is a flexible, configurable Up and Downconverter for use in broadcast and post. It can process SD (Standard Definition) signals into HD, downconvert HD signals into standard definition, and perform Format and Aspect Ratio Conversion on both SD and HD signals. The 7900 and one of the optional audio sub modules together only occupy one slot in an Avenue frame – now that's efficient use of space.

### It's Smart – No Need for Configuration

The 7900 can be configured to continually output your facility's preferred HD format. Just connect any HD or SD signal to the input and the 7900 will convert it to the appropriate format for output. And, if the 8415 audio option is installed, the audio will have automatic delay compensation.

### Upconversion

When configured as an upconverter, the 7900 has a standard definition SDI input and four HD SDI outputs. Excellent for on-air use, the 7900 is equally at home in an HD island, in a signal ingest installation, or in a production application.

The 7900 uses sophisticated Edge and Motion Adaptive Noise Reduction, ensuring delivery of a pristine output that is excellent for use in broadcast. All processing is performed on progressive signals at full bandwidth 4:4:4, for optimum signal quality. Signals are interlaced and deinterlaced as required with motion adaptation and edge interpolation. Aspect ratio conversion choices include: Letterbox, Anamorphic, Crop and Zoom.

Input standard and frame rate are auto-detected. The 7900 automatically performs 16 bit SD and HD color space conversion. The built-in Proc Amp provides adjustment of signal parameters with controls for Video, Chroma, Setup and Hue. Vertical interval data is faithfully preserved and is passed from SD to HD. The upconverted output is timeable with respect to the reference input.

### Downconversion

When used as a downconverter, the 7900 has an HD SDI input and four outputs that can be configured as two SDI and two composite outputs, or four SDI outputs. Whether it's providing digital feeds to production switchers and routers, or analog monitoring – the 7900 handles it all.

The downconversion process includes Picture Detail Enhancement and Anti-Alias Filtering, which makes for a pristine SD output.

The Aspect Ratio Conversion process offers Resizing and Repositioning with choices for: Letterbox, Anamorphic, Crop and Zoom. The 7900 automatically adjusts between HD and SD color space and gamma. Proc amp controls are provided in the form of Video, Chroma, Setup and Hue.

Both the digital and analog outputs are timeable with respect to the reference input.

### Cross Conversion

The 7900 provides cross conversion between HD 1.5 Gb/s formats, processing all popular variations of 1080 and 720, making it simple for every facility to ingest any type of HD signal.

All popular variations of 720p, 1080i, 1080sF and 1080p are supported. The 7900 converts between any HD signals within the 59.94/23.98/29.97 family, within the 50/25 fps family, or within the 60/30 fps family. 3:2 pulldown is used when converting between 59.94 and 23.98. Film mode is automatically detected.

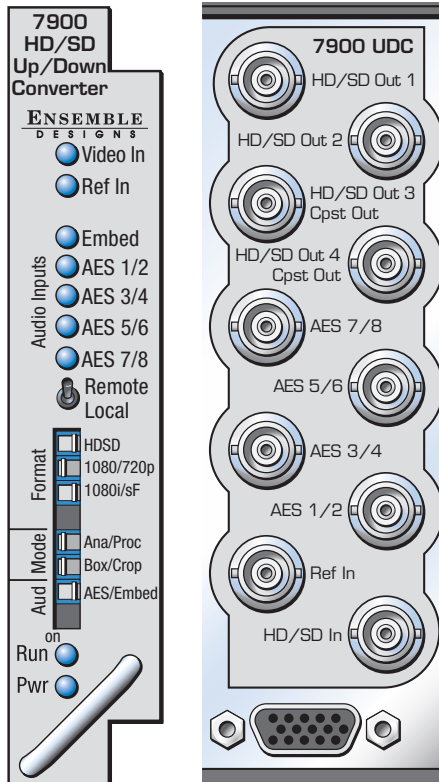

## Metadata

HD closed captioning is carried in data packets in the vertical interval ancillary data space. The 7900 properly translates between HD caption data and traditional SD captioning (line 21 or 23) so that closed captioning content is converted transparently between video standards and formats.

## Automatic Aspect Ratio Conversion

The 7900 supports AFD (Active Format Description) to mark or identify the aspect ratio of the video content. These flags are generated at the output of the module, and they are read at the input. This allows the up and downconversion process to adapt automatically to material that is already in letter or pillarbox form in order to produce the most appropriate conversion.

## Audio Options

When an audio sub module is installed, audio is automatically delayed as needed to compensate for the video processing in the 7900. For complete audio processing, choose from three different audio sub modules. Sub modules plug onto the 7900 board and do not take up a slot in the frame.

The 8415 is an eight-channel audio sub module with AES I/O that provides management of embedded audio in the processing path, or supports audio embedding/disembedding alongside the video processing elements. Embedded audio is safely bypassed around the video frame store with the lip sync preserved. Level adjustments and channel shuffling are accessed through the built-in audio mixer. The 9670 Automatic Gain Control option can be added to the 8415. All audio processing is performed at full 24 bit resolution.

The 7610 sub module option provides carriage of up to eight channels of embedded audio through the format conversion process. Embedded audio in the input signal is delayed to match the video delay and preserve lip sync. The delayed content is reinserted in the video output. No level adjustment or channel swapping is provided.

## Complete Control System

The 7900 can be configured locally or controlled and configured remotely with Avenue Touch Screens, Express Panels, or Avenue PC Software. Alarm generation, configurable user levels, module lock out, and customizable menus are just some of the tools included in the Avenue Control System.

## Features

- **Upconverter**
- **Downconverter**
- **Cross converter**
- **Aspect Ratio Converter**
- **Smart auto-config – set output, then feed any input**
- **Proc Amp and Frame Sync**
- **Audio Mux/Demux optional**
- **Audio Automatic Gain Control optional**
- **Add audio sub module option for delay and processing**
- **All internal processing performed on 4:4:4 progressive signals**
- **Accepts asynchronous signals**
- **Reference input – output is timeable**
- **Automatically adjusts between SD/HD color space and gamma**
- **16 bit processing**
- **Edge and Motion Adaptive Noise Reduction**
- **Picture Detail Enhancement**
- **Anti-Alias Filter**
- **Passes closed captioning**
- **Auto detection of input standard and frame rate**
- **3:2 pulldown**
- **Built-in test pattern and tone**
- **Local and remote control**

# 7900

## HD Up/Down/Cross Converter

### Serial Digital Input

Number	One
Signal Type	HD Serial Digital 1.485 Gb/s SMPTE 274M, 292M or 296M or SD Serial Digital 270 Mb/s SMPTE 259M (Both 525 and 625 SD standards)
Impedance	75 Ω
Return Loss	>15 dB
Max Cable Length	270 Mb/s 300 meters Belden 1694A 1.485 Gb/s 100 meters Belden 1694A

Automatic Cable Input Equalization

### HD Standards Supported

- 1080i 50, 59.94 or 60 Hz, SMPTE 274M -4,5,6
- 720p 50, 59.94 or 60 Hz, SMPTE 296M -1,2,3
- 1080p 23.98, 24 or 25 Hz, SMPTE 274M -9,10,11
- 1080sF 23.98, 24 or 25 Hz, RP211 -14,15,16
- 525i 59.94, 625i 50

### Serial Digital Output

Number	Two, Three or Four Selectable
Signal Type	SMPTE 274M, 292M or 296M when HD SMPTE 259M (525 or 625) when SD
Impedance	75 Ω
Return Loss	>15 dB
Output DC	None (AC coupled) Delay Adjustable from 1 field to 1 frame

### Reference Input

Number	One external (modules BNC) One internal (frame master ref BNC)
Signal Type	PAL or NTSC composite video or Tri-Level Sync
Return Loss	>40 dB (applies to external ref input)

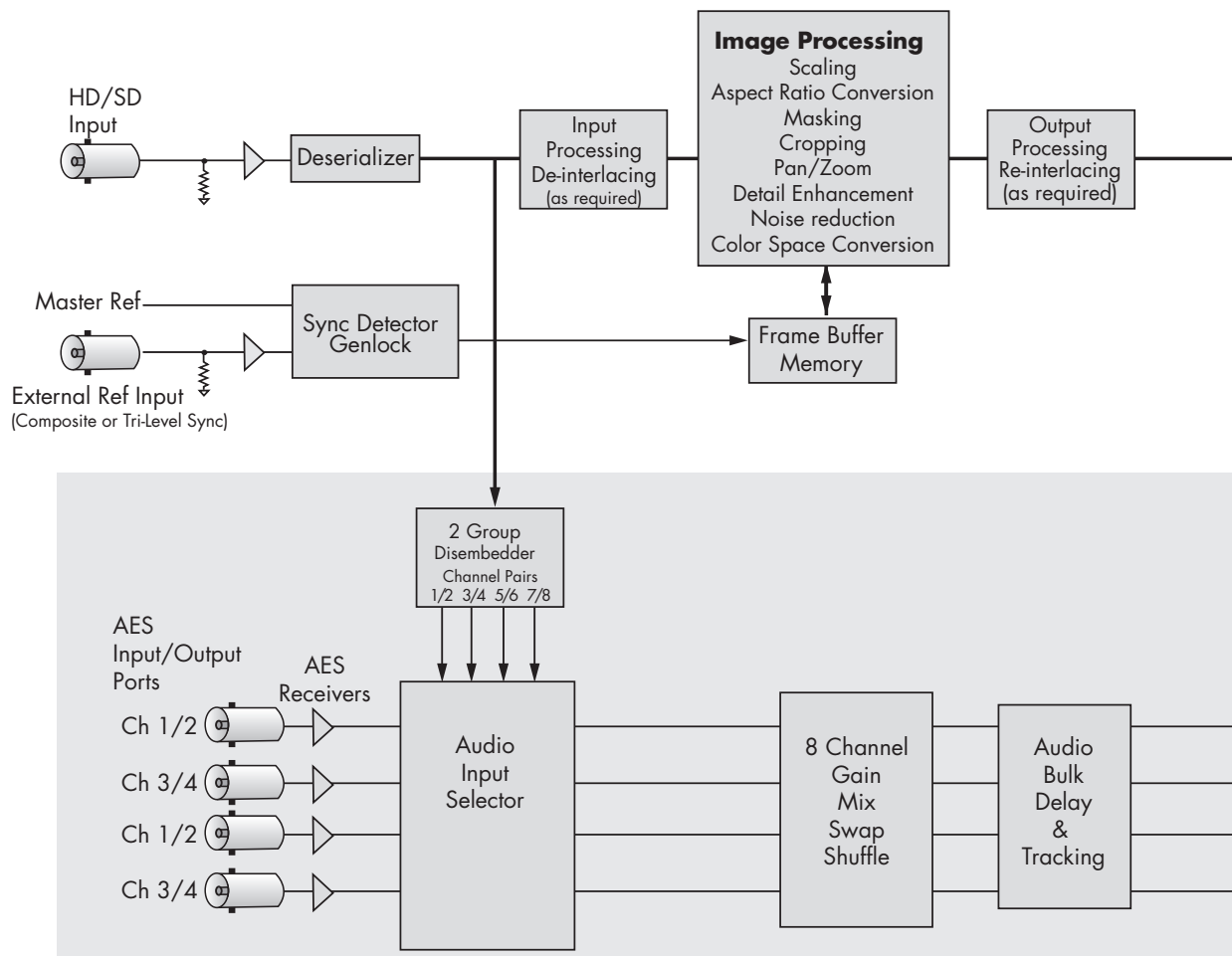

Avenue 7900 HD Up/Down/Cross Converter

**Analog Output (available when output is SD)**

Number	Two max (BNCs shared with SD SDI outputs)
Signal Type	PAL or NTSC composite Standard matches SDI output
Impedance	75 $\Omega$
Return Loss	>40 dB
Output DC	<50 mV
Bit Resolution	12 bit output reconstruction 8 x oversampling
Signal to Noise	>65 dB
Frequency Response	$\pm 0.1$ dB, 0 to 5.5 MHz
K Factor	<1%
Differential Phase	<1 degree
Differential Gain	<1%

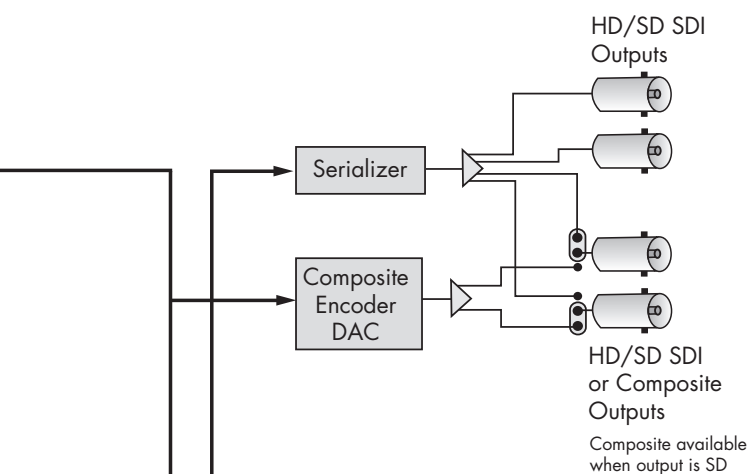
**8415 8 Channel Audio Processing Option****Conversion Directions**

Up/Down Conversion between  
 525 (NTSC) and 1080i/59.94, 720p/59.94, 1080p/23.98, 1080sF/23.98  
 625 (PAL) and 1080i/50, 720p/50, 1080p/25, 1080sF/25  
 Cross Conversion within frame rate families  
 525 Derived Family: 1080i/59.94, 720p/59.94, 1080p/23.98, 1080sF/23.98  
 625 Derived Family: 1080i/50, 720p/50, 1080p/25, 1080sF/25

**AES/EBU Digital Inputs (with 8415 sub module option)**

Number	Four (total of 8 channels)
Signal Type	AES3id
Connector	Coaxial, 75 $\Omega$
Bit Depth	20 and 24 bit
Sample Rate	30 kHz to 100 kHz (sample rate converted internally to 48 kHz)
Crosstalk	<144 dB
Dynamic Range	>144 dB
Reference Level	-18 or -20 dBFS (selectable)
AC-3, Dolby E	Supported when inputs are synchronous

**Embedded Inputs**

Number	Four AES Streams (from video input) Eight channels from any two of four groups Selectable to any of four groups
Channels	Eight
Bit Depth	20 and 24 bit

**AES/EBU Digital Outputs**

Number	Four (total of eight channels)
Signal Type	AES3id
Connector	Coaxial, 75 $\Omega$
Bit Depth	20 and 24 bit
Sample Rate	48 kHz Synchronous to video output
Reference Level	-18 or -20 dBFS (selectable)

**Embedded Output**

Number	Four or two depending on configuration
Group Assign	Cascade or replace any two of four groups
Channels	Eight
Bit Depth	24 bit

**General Specifications**

Power Consumption	10 watts
Temperature Range	0 to 40°C ambient (all specs met)
Relative Humidity	0 to 95%, noncondensing
Altitude	0 to 10,000 ft