

7435

HD/SD Clean and Quiet Protection Switch

A Clean Switch That's Glitch-Free

The 7435 module is a clean and quiet protection switch for critical broadcast and satellite feeds. It switches cleanly between asynchronous sources which means it can be used live to air. The module has a full video frame synchronizer, rather than a line delay, ensuring perfect alignment of mis-timed and non-synchronous SDI sources.

Clean and quiet switching between sources requires that they be synchronous and precisely timed to each other. The 7435 accomplishes this automatically, with integral frame synchronization of the inputs, allowing operation with both synchronous and asynchronous (wild) sources. This frame synchronization feature not only means that the output of the 7435 will always be stable and glitch-free, but it also means that in the event of a total loss of both inputs, consistently timed color black will still be output.

These internal frame synchronizers can be genlocked to an external reference signal so that the output of the 7435 is synchronous to local sources. Alternately, in teleports, headends, and other multi-service facilities, where there is no logical common reference, the 7435 will internally generate an accurate reference.

The delay through the 7435 can be adjusted from one to eight frames, with independent control for the Primary and Secondary input paths. By operating with several frames of delay, the fault detection algorithms are given enough time to detect a failure in an input signal and switch to the backup before the fault has actually appeared on-air.

Features

- **Clean and quiet switch for SD and HD SDI signals**
 - **Use for clean switching of asynchronous sources for critical, live feeds**
 - **Full frame synchronizer with adjustable delay**
 - **Quiet audio switching**
 - **Passes embedded audio**
 - **External genlock reference input**
 - **GPIs and TCP/IP for automation control**
 - **Fail-safe bypass in case of power failure**
 - **Local and remote control**
 - **Memory Registers**
-

Perfect Audio

Glitch-free, quiet switching of embedded audio signals is achieved with the 7435's precise synchronization and alignment of audio sources. Digital audio is de-embedded, and if it is linear PCM, sample rate converted, switched, and re-embedded. Encoded audio streams such as Dolby™ E are de-embedded and re-embedded but not processed in any way. PCM audio is supported with asynchronous sources, operation of encoded audio requires all sources to be synchronous, but not necessarily in time.

Switch Logic

When a fault is detected in the primary input to the 7435, and the secondary input is verified as good, the switch will activate, causing the secondary input to be switched to the module's output. The 7435 includes a passive, fail-safe path that ensures there is an output even in the event of a total power failure. The module can be set to automatically switch back to the primary after the fault condition clears. If both the primary and the secondary inputs signals are faulted, no switch occurs.

The health of a high definition or standard definition video signal is determined by monitoring crucial parameters in order of increasing complexity; Timing Reference Signal (TRS), or a persistent loss of digital sync is tested first. Black, Embedded Audio and Freeze are also evaluated. Each test can be configured by the user. For example, the sophisticated Black Detector includes configurable parameters for black level threshold, pixel count, and duration time.

The Freeze detection system can be set to detect a clean or noisy source. Freeze Time sets the number of seconds for the 7435 to switch to the secondary input after a video freeze condition is detected in the primary input.

Control and Alarms

Module controls are easily accessed through an Avenue Control Panel, Avenue PC software, GPIs, or the module's front edge controls. GPI inputs allow faults detected in upstream equipment to contribute to the switching logic.

HD/SD Clean and Quiet Protection Switch

Input

Number	Two
Signal Type	HD Serial Digital 1.485 Gb/s, SMPTE 274M, 292M or 296M SD Serial Digital 270 Mb/s, SMPTE 259M Data, SMPTE 337M
Impedance	75 Ω
Return Loss	>15 dB to 1.5 GHz
Max Cable Length	270 Mb/s 300 meters Belden 1694A 1.485 Gb/s 100 meters Belden 1694A
Automatic Cable Input Equalization	

Standards Supported

- 1080i 50, 59.94 or 60 Hz, SMPTE 274M -4,5,6
- 720p 50, 59.94 or 60 Hz, SMPTE 296M -1,2,3
- 1080p 23.98, 24 or 25 Hz, SMPTE 274M -9,10,11
- 1080sF 23.98, 24 or 25 Hz, RP211 -14,15,16
- 525i 59.94, 625i 50

Serial Digital Loopback

Number	Two total One primary One secondary
Impedance	75 Ω

Output

Number	Six (includes one fail-safe bypass)
Signal Type	HD or SD Serial Digital, follows input
Delay	Adjustable up to 8 frames
Impedance	75 Ω
Return Loss	>15 dB DC to 1.5 GHz

Reference Input

Number	One external (modules BNC) One internal (frame master ref BNC)
Signal Type	PAL or NTSC composite video or Tri-Level Sync
Return Loss	>40 dB

General Specifications

Power Consumption	10 watts
Temperature Range	0 to 40°C ambient (all specs met)
Relative Humidity	0 to 95%, noncondensing
Altitude	0 to 10,000 ft
7435 module cannot be installed in slot 3 of a 1RU frame when 5035 System Control module is installed	

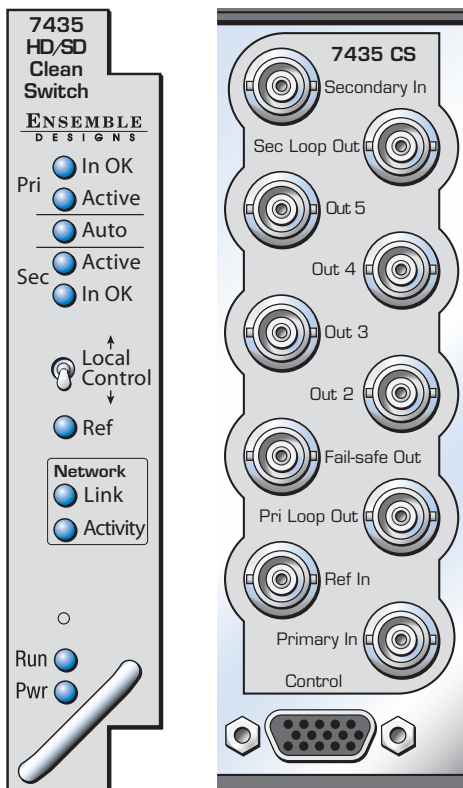

7435

HD/SD Clean and Quiet Protection Switch

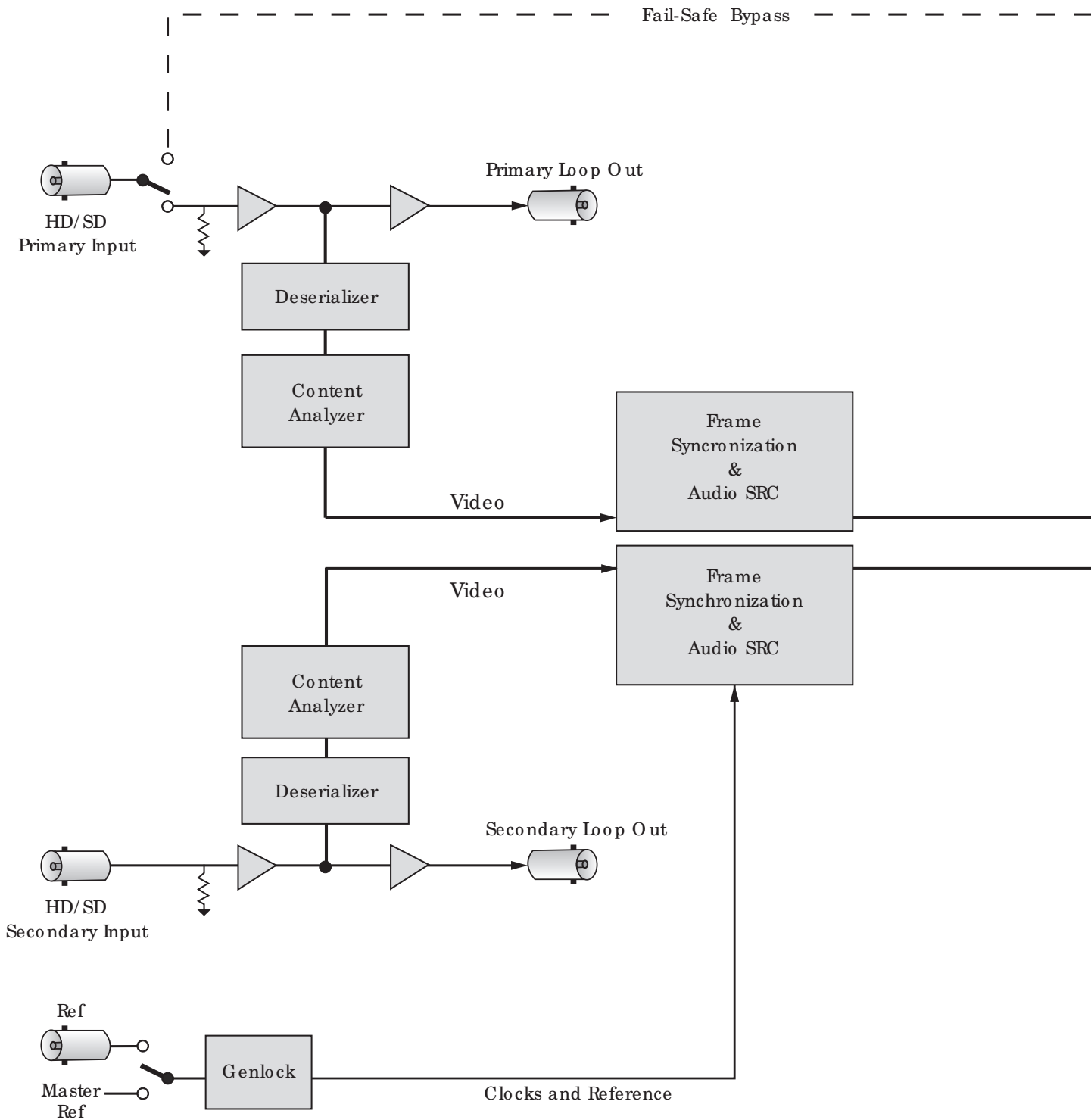

HD/SD Clean and Quiet Protection Switch

