

# 7400

## HD/SD Sync Pulse Generator and Test Signal Generator

---

### 7400 SPG/TSG – Reliable and Easy-To-Use

The 7400 HD/SD Sync Generator and Test Signal Generator is a stable timing source that is perfect for local reference generation in broadcast, remote trucks and post. HD SDI, SD SDI, analog composite, Tri-Level Sync, timecode, AES audio and analog audio reference outputs are generated.

The 7400 can operate from an internal precision frequency reference as a stand-alone Master Sync Generator or lock to a video reference or 10 MHz precision reference. Alternately, the 7400-GPS option can be used. If the external reference is lost, the 7400's softlock provides a graceful transition to the internal TCXO, ensuring consistent reference output.

The 7400 can output multiple formats of Tri-Level Sync, HD SDI test signals, SD SDI and composite test signals, and color black reference. The 7400 can simultaneously deliver both 525 (NTSC) and 625 (PAL) based signals. Color framing tracks the reference signal. All of the video outputs are derived from the same time base and can be timed with respect to each other. The 7400 has two identical generators, Generator A and Generator B, each with a variety of outputs. Each set of outputs can be timed with respect to the reference to any point in the television frame. All of the outputs from a particular generator must be selected within the same frame rate family.

The Avenue Frame features a retainer bar to ensure that modules remain properly seated even in the most demanding mobile environments.

### Favorite Test Patterns

There are over 30 test signals including: Full and Split Field Bars at 75% and 100% with Pluge; Black; Flat Field; Pulse and Window; Ramp; Crosshatch; Safe Title; Blanking Markers; Cosite; Checkfield, Pathogenic, and 5 Step. The Cyclops feature adds a motion element to the selected video test signal to assist in locating a signal that might be frozen in a frame sync somewhere in the signal chain. An ID slate with user programmable text can overlay the test pattern.

### Customizable Test Patterns

In addition to the standard suite of test patterns, users can create custom test patterns on a computer. Simply transfer test patterns to the included Secure Digital flash memory card using Avenue Logo software and a standard SD card reader, then insert the memory card into the 7400. Custom test patterns can also include motion.

### Audio Generators

The 7400 provides extensive support for analog and digital audio. Because all of the video outputs can be locked to a common time base, the AES digital audio outputs are always synchronous with all of the video outputs – regardless of format. Multiple tone generators make it easy to identify multi-channel content. This bitstream will be included in the set of signals that can be embedded into the test signal outputs.

The audio section of each generator supports sixteen audio channels. The content of each channel is independently programmable. Choices include adjustable frequency tone generators, tone sweeps, silence and timecode. Left/Right Channel ID that synchronizes to the Cyclops feature can also be selected.

All sixteen of these channels can be embedded in the SDI outputs. Each AES output can select from any of the 8 pairs that make up these 16 channels. Similarly, the stereo analog output of each generator can be driven from any of these audio signal pairs.

### Multiple Timecode Generators

Multiple timecode generators make the 7400 convenient for post applications. Timecode is delivered as LTC (both 75 Ohm BNC and 110 Ohm Balanced), VITC, and DVITC. One generator can be configured to produce 525/59.94 drop frame timecode while the other generator is making 1080sF/23.98.

### 7400-GPS Option for the Ultimate Precision Reference

For the ultimate in precision, the 7400-GPS option can be used with the 7400 module. The purpose of this GPS option is to provide an extremely precise frequency reference. The oscillator on the 7400-GPS is more accurate than a typical internal precision standard and is equivalent in accuracy to an atomic standard. Increased frequency accuracy makes it possible to frame synchronize signals between different facilities with virtually no dropped or doubled frames. The GPS option also provides precise time of day information, which can be used to drive the 7400 module's internal timecode generators.

## HD/SD Sync Pulse Generator and Test Signal Generator

The 7400-GPS option seamlessly integrates into the Avenue system by plugging directly onto the 7400 module. It can be easily installed in the field. The 7400-GPS option consists of a compact, weatherproof antenna (with internal high-gain pre-amp) and a receiver sub module which mounts directly to the 7400 module. The included GPS antenna mounts onto standard 3/4" threaded pipe, metal or plastic. Connection from the F-style coaxial fitting on the antenna to the appropriate BNC on the Avenue Frame can be made with customer supplied standard 75 ohm cable. The coax cable can be routed through the center of the pipe for a completely waterproof installation. When low loss cable such as Belden 1694A is used, the antenna can be placed up to 200 feet (60 meters) from the frame. Ideally, the antenna is mounted outdoors where it has an unobstructed view of the sky.

### A Complete SPG and TSG System

The 7400 can be combined with other Avenue modules to create a complete sync pulse and test signal chain. The 7410 is a four channel Tri-Level Sync generator that can output four different types of Tri-Level Sync simultaneously and is very useful in post and hybrid facilities. The 5150 distribution amplifier can be used to distribute multiple copies of AES audio, Tri-Level Sync or composite black signals as needed. For HD test signal and black distribution, either the 9110 DA or 9125 DA are a good fit.

### Features

- Use as Master Sync Gen or lock to external reference or GPS
- Can output SD SDI, HD SDI, composite, timecode and audio simultaneously
- Softlock provides graceful transition to internal TCXO if external reference is lost, ensuring consistent reference output
- Outputs can be independently timed
- Generates 30+ test signals
- Generates closed caption test sequence to test for compliance
- Dual Link test patterns
- Flash memory card for making custom test patterns

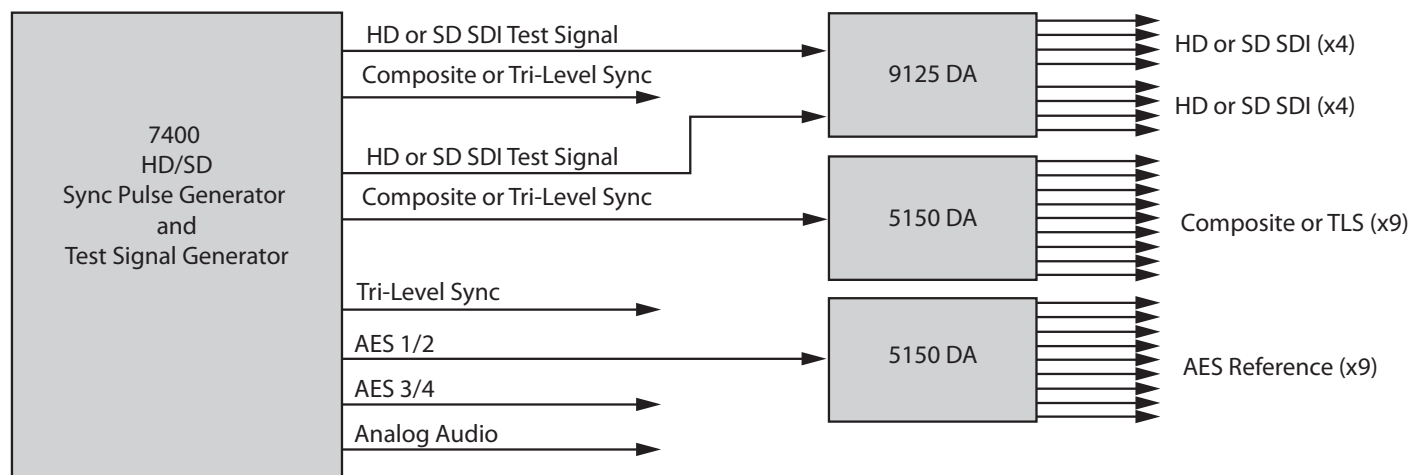

# 7400

## HD/SD Sync Pulse Generator and Test Signal Generator

### Description of Outputs

#### Generator A

**SDI Out A** – Outputs HD or SD test signals. Select frame rate family for all of Generator A; 59.94, 50 or 60. Output can include 16 channels of embedded audio. The embedded audio can be any combination of the following: tone, silence, external audio. Can also include DVITC.

**Programmable Out 1A** – Outputs analog composite black, composite 100% bars, or Tri-Level Sync from TLS Gen 1. When SDI Out A is a SD test pattern, this BNC can also output a composite version of that test pattern. Composite output can include VITC.

**Programmable Out 2A** – Outputs one of the following: Tri-Level Sync from TLS Gen 2 (can be different from Out 1A), LTC, AES (any of 8 pairs), AES silence, Word Clock, 6 Hz pulse, 10 MHz (only if locked to internal or GPS reference).

**Programmable Out 3A** – Outputs one of the following: Tri-Level Sync from TLS Gen 2 (same as Out 2A), LTC, AES (any of 8 pairs), AES silence, Word Clock, 6 Hz pulse, 10 MHz (only if locked to internal or GPS reference).

**Analog Audio** – Stereo output, 1 of 8 pairs from the audio generator.

#### Generator B

Has the same outputs as noted for Generator A. Generator B is completely independent from Generator A. Generator B can operate in a different frame rate family and its set of outputs can be timed independently.

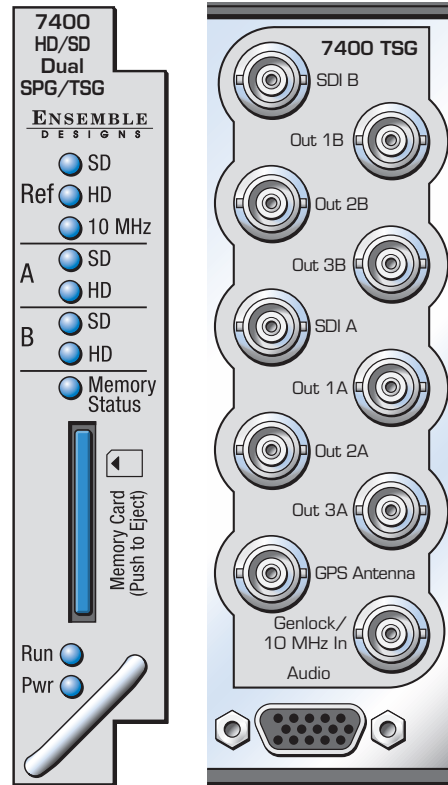

### Order Info

7400	SPG/TSG Module
7400-GPS	GPS receiver option that plugs onto 7400 module. (Does not take up a slot in Avenue frame) Includes weatherproof antenna. Antenna mounts onto standard 3/4" pipe. Customer to provide 75 $\Omega$ 1694A coax up to 60 m/200 ft with F connector for antenna connection and BNC for Avenue frame connection.

# HD/SD Sync Pulse Generator and Test Signal Generator

## Standards Supported

1080i 50, 59.94 or 60 Hz, SMPTE 274M -4,5,6  
 720p 50, 59.94 or 60 Hz, SMPTE 296M -1,2,3  
 1080p 23.98, 24 or 25 Hz, SMPTE 274M -9,10,11  
 1080sF 23.98, 24 or 25 Hz, RP211 -14,15,16  
 625i 50, 525i 59.94  
 Composite PAL, NTSC

## Frame Rate Families

Each 7400 has 2 identical Generators, each with a variety of outputs.  
 All of the outputs from a particular Generator must be selected within the same frame rate family.

50 Hz (625) Derived Family: 1080i/50, 720p/50, 1080p/25, 1080sF/25, 625i/50  
 59.94 Hz (525) Derived Family: 1080i/59.94, 720p/59.94, 1080p/23.98,  
 1080sF/23.98, 525i/59.94  
 60 Hz Derived Family: 1080i/60, 720p/60, 1080p/24, 1080sF/24

## Reference Input

Number	Two One external (modules BNC) One internal (frame master ref BNC)
Signal Type	PAL or NTSC composite video or Tri-Level Sync or 10 MHz 1V P-P sine or square
Return Loss	>40 dB (applies to external ref input)

## Serial Digital Outputs

Type	HD Serial Digital 1.485 Gb/s SMPTE 274M, 292M or 296M or SD Serial Digital 270 Mb/s, SMPTE 259M
Impedance	75 Ω
Return Loss	>15 dB
Max Cable Length	300 meters for SD 270 Mb/s Belden 1694A 100 meters for HD 1.485 Gb/s Belden 1694A

## Tri-Level Sync Outputs

Signal Type	Tri-Level Sync
Output DC	±50 mV
Return Loss	>30 dB to 30 MHz

## Composite Outputs

Signal Type	NTSC/PAL
Impedance	75 Ω
Return Loss	>40 dB DC to 5.5 MHz
Frequency Response	±0.1 dB 0 to 5.0 MHz
Output DC	±50 mV
K Factor	<1.0%
Differential Phase	<1.0 degree
SCH Phase	±2 degrees
Delay	adjustable over full frame in sub degree steps
Color Framing	Tracks reference

## Accuracy

Internal Reference (TCXO)	
Freq Error	<10 <sup>-7</sup> < ±1 Hz F <sub>sc</sub>
GPS Option	
Freq Error	<10 <sup>-12</sup>

## Stability

Analog Jitter	<1 ns
Digital Jitter	<0.2 UI (0.13 UI typical)
AES Jitter	<1 ns

## AES Audio Outputs

Type	AES3id tone, 300 Hz to 1.6 KHz, or silent
Resolution	24 bit

## Analog Audio Outputs

Number	Two stereo pairs or four mono
Type	tone, 300 Hz to 1.6 KHz, or silent
Impedance	30 Ω, balanced
Reference Level	-10 to + 4 dBu, selectable

## Additional Output Choices

Timecode	DVITC on the SDI outputs VITC on the composite outputs LTC on BNC prgm 2/3 unbalanced or on HD-15 balanced, 1 V P-P drop or non-drop for NTSC
6 Hz Pulse	
Word Clock	
10 MHz	when locked to internal or GPS reference

## Flash Memory

Number	One
Type	Secure Digital SD Flash Memory Card
Size	2 GB card included

## File Type

Video	.tga
-------	------

## General Specifications

Power Consumption	10 watts for 7400
Temperature Range	0 to 40°C ambient (all specs met)
Relative Humidity	0 to 95%, noncondensing
Altitude	0 to 10,000 ft
7400 module cannot be installed in slot 3 of a 1RU frame when 5035 System Control module is installed	

# 7400

## HD/SD Sync Pulse Generator and Test Signal Generator

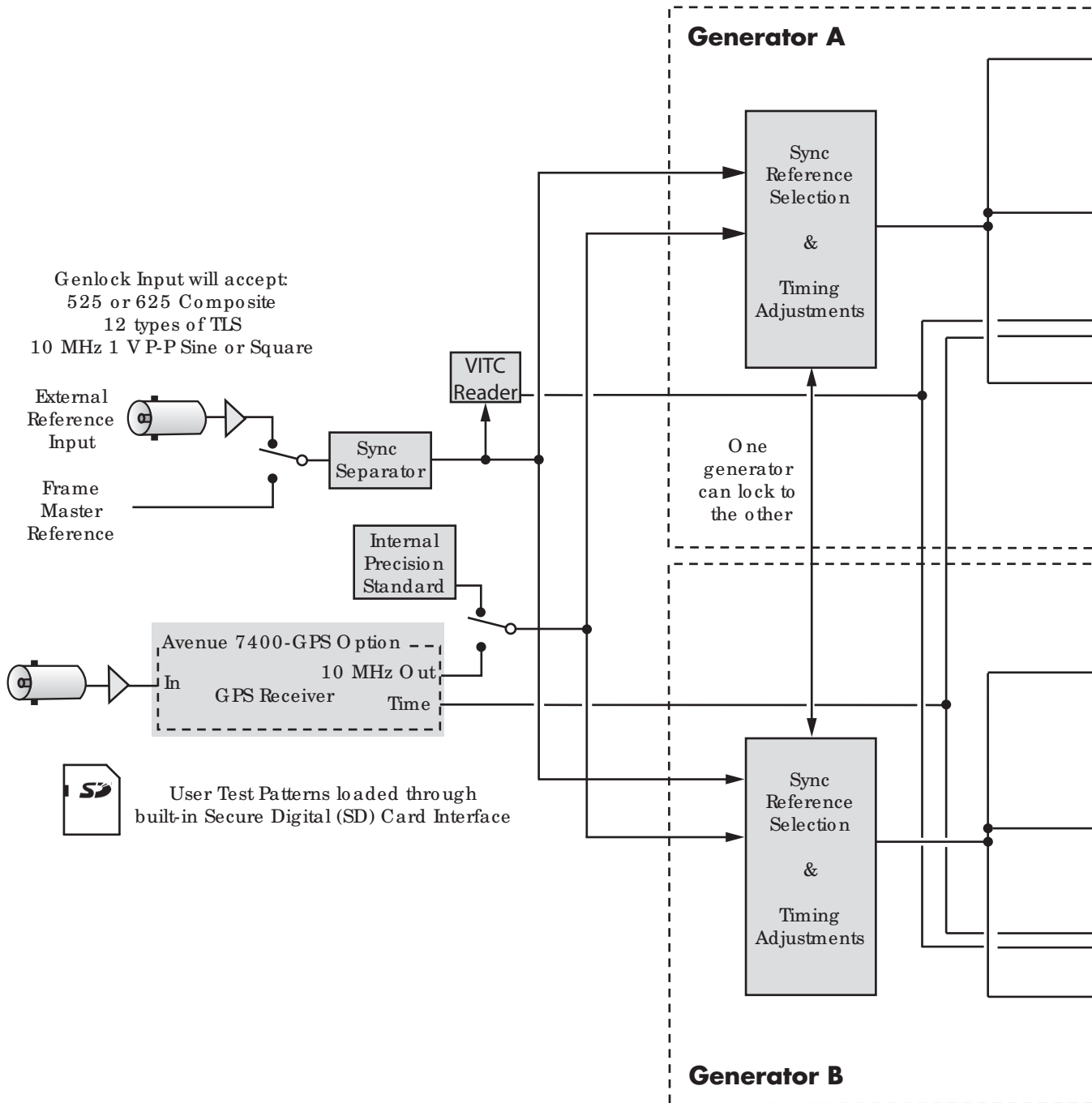

# HD/SD Sync Pulse Generator and Test Signal Generator

