

5330 and 6330

Analog to SD Digital Video Converter and Embedder

The 5330 converts a composite or component analog video signal to serial digital component. Its 12 bit processing and 4 x oversampling ensure clean signals that can be used in the most demanding applications. Composite signals are decoded using an adaptive comb filter. An infinitely adjustable timing system genlocks to your house reference.

The built-in time base corrector/frame synchronizer allows for removal of time base error present in the composite input. The 5330 accepts asynchronous inputs and delivers serial outputs locked and timed to house reference. Robust signal handling ensures proper time base correction for virtually any source, even a consumer VHS machine. On loss of input, the output can mute to black or freeze on the last good frame of video.

A Detail Enhancer recovers information that has been lost due to poor frequency response in upstream systems. The Predictive Composite Clipper mode identifies picture elements that would be illegal in analog composite, and limits color saturation and luminance excursions. Proc controls are also provided.

The optional 6330 sub module provides embedding of analog or AES audio. Analog inputs are digitized at 24 bits of resolution. Two AES inputs provide four channels of digital audio to the input selector. Sample rate converters can be selected in the AES input path, allowing the use of asynchronous digital sources. A four channel audio mixer provides level control, phase inversion and channel shuffling. The 6330 also has automatic tracking delay and bulk delay.

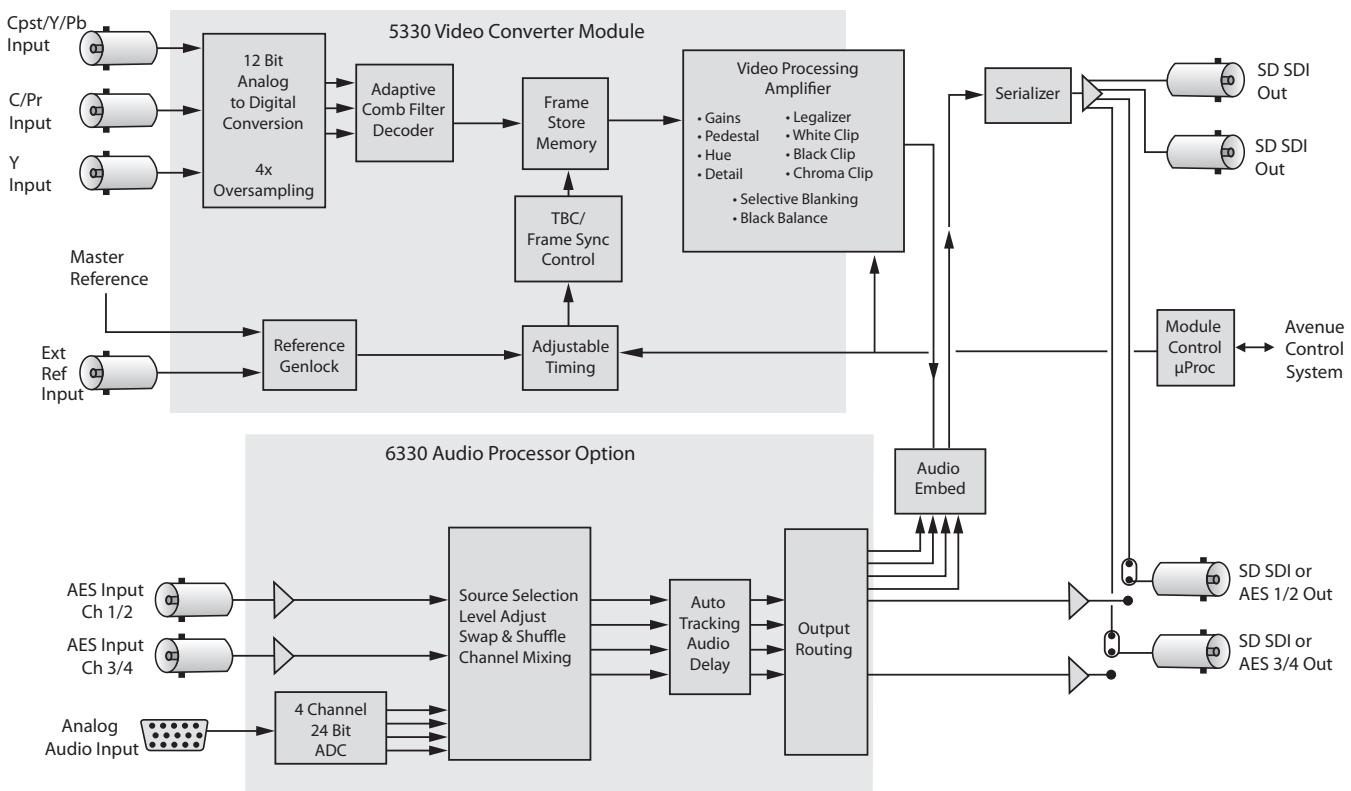
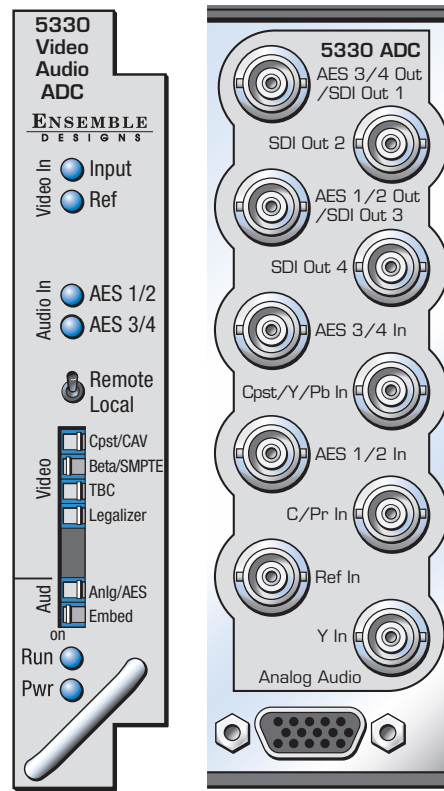

5330 and 6330

Analog to SD Digital Video Converter and Embedder

Features

- **Converts Y, Pr, Pb composite or Y/C (S-Video) to serial digital component**
- **Two or four serial digital outputs**
- **12 bit internal processing, 4 x oversampling**
- **Complete proc amp adjustments**
- **Adaptive comb filter**
- **Automatic 525/625 switching**
- **Memory registers**
- **Line selectable toothed blanking**
- **EDH detection and insertion**
- **TBC/Frame Synchronizer**
- **Optional embedder, audio shuffler and tracking delay**
- **110 option**

Analog Inputs

Signal Type	SMPTE Y/Cr/Cb Beta Y/Cr/Cb NTSC, PAL Composite NTSC, PAL S-Video (Y/C)
Impedance	75 Ω
Return Loss	>40 dB
Input	±1 volt DC
Input Hum	<100 mV

Reference Input

Number	Two: One external One internal Master Timing Ref
Type	1 V P-P Composite Video PAL or NTSC
Impedance	75 Ω
Return Loss	>40 dB

Analog to SDI Performance

Bit Resolution	12 bit input quantization 4 x oversampling
Signal to Noise	>62 dB, weighted
Frequency Response	
Composite, Y	±0.1 dB, 0 to 5.5 MHz
Cr, Cb	±0.1 dB, 0 to 2.75 MHz

Serial Output

Number	Two or Four (selectable)
Signal Type	Serial Digital SMPTE 259M
Impedance	75 Ω
Return Loss	>15 dB
Output DC	None (AC coupled)
Delay	1 line, adjustable up to 1 frame

Analog Audio Input (6330 sub module)

Analog Inputs	Four, Balanced Pair
Processing	24 bits
Analog Input Z	>15 k Ω, balanced, transformerless
CMRR	>60 dB, 20 Hz to 10 kHz

AES Input (6330)

Number	Two AES
Channels	Four total
Signal Type	AES Coaxial 20 or 24 bit
Impedance	75 Ω

AES Outputs (6330)

Number	Two AES or none (selectable)
Channels	Four total
Signal Type	AES3id
Connector	Coaxial, 75 Ω
Bit Depth	20 and 24 bit
Sample Rate	48 kHz, synchronous to video output
Reference Level	-18 or -20 dBFS (selectable)

General Specifications

Power Consumption	10 watts (with both options installed)
Temperature	0 to 40°C ambient (all specs met)
Relative Humidity	0 to 95%, noncondensing
Altitude	0 to 10,000 ft