

# 5230 and 6230

## SD Digital to Analog Video Converter and Disembedder

The 5230 converts serial digital component video into either composite or component analog outputs. Its 8 x oversampling and 12 bit processing ensure high quality conversion for use in the most demanding applications.

The 5230 has a full-featured Proc Amp for adjustment of every signal parameter. Proc controls include Video and Chroma Gain, NTSC-style hue rotation, Black Balance, and pedestal. Module parameters can be monitored and controlled locally and remotely.

The 5230 provides fully adjustable output timing relative to the reference input signal. Composite outputs can be precisely color timed and will also track color framing of the reference signal. Incorporating a full-frame synchronizer, the 5230 accepts serial inputs that are asynchronous to the reference. On loss of input, the output can mute to black or freeze on the last good frame of video.

The 6230 is an optional sub module for converting AES inputs or embedded audio content to analog. There is a four channel audio mixer for level controls, audio shuffling, and phase inversion. The 6230 also has automatic tracking delay and bulk delay to keep lip sync correct.

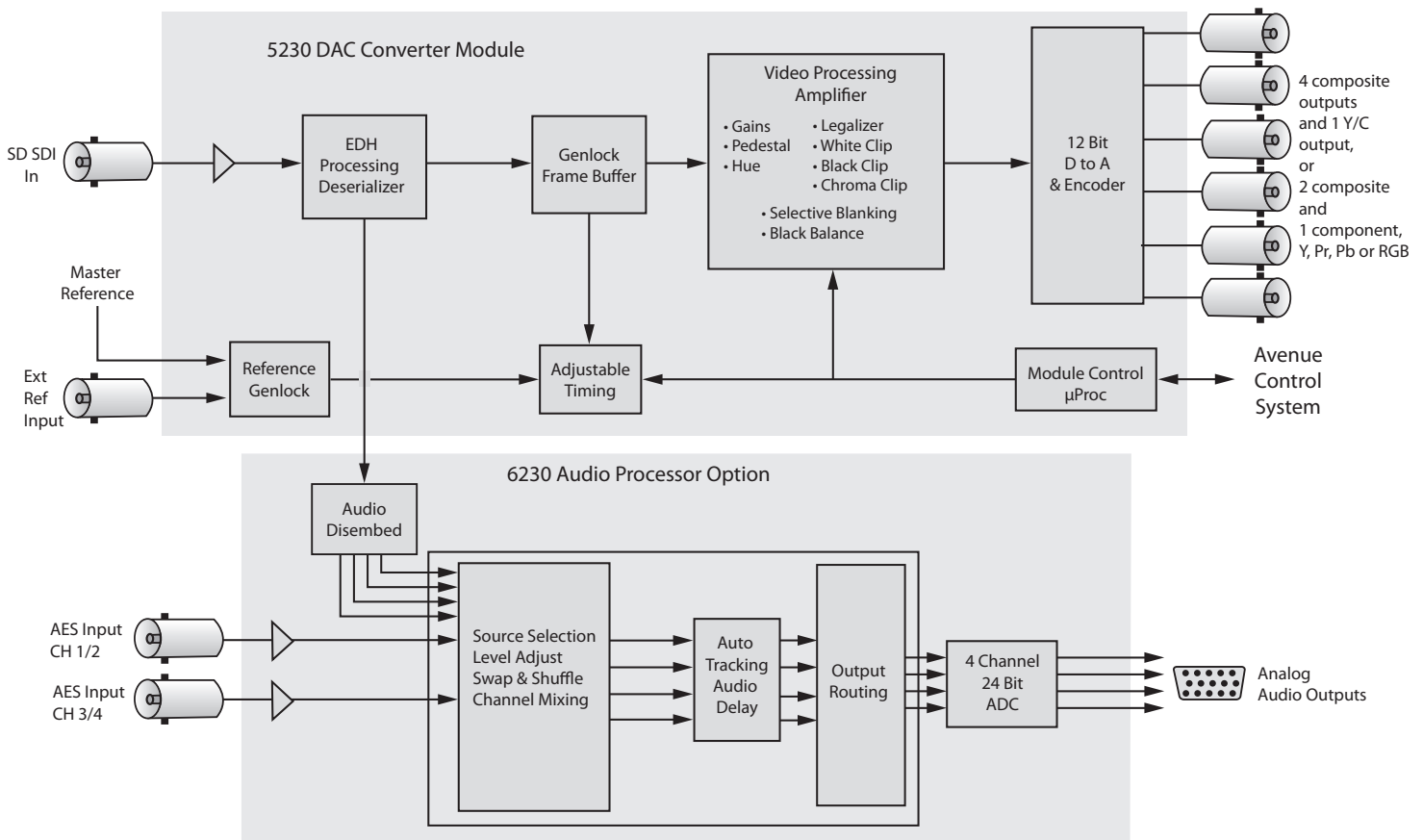
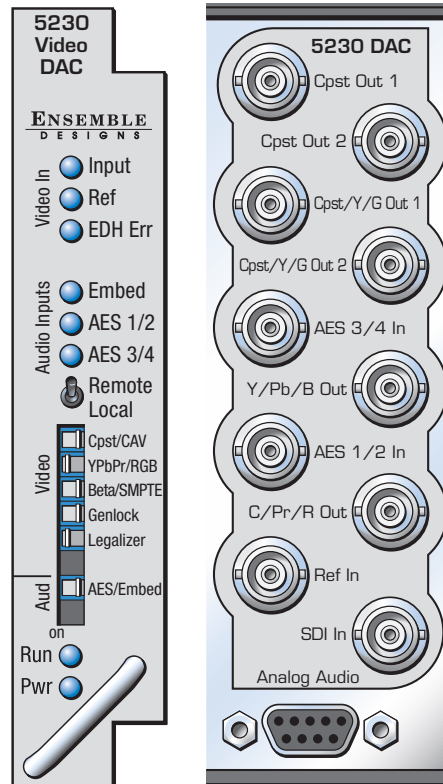

# 5230 and 6230

## SD Digital to Analog Video Converter and Disembedder

### Features

- **Component or composite or Y/C (S-Video) outputs**
- **12 bit conversion**
- **8:8:8 video reconstruction with 8 x oversampling**
- **Proc Amp adjustments and SC/H timing controls**
- **Line selectable toothed blanking**
- **Clips and Chroma limiting**
- **Composite legalizer**
- **Generates color bars**
- **Memory registers**
- **Genlock/Frame sync**
- **Automatic 525/625 switching**
- **Optional sub module for disembedding, audio shuffling and adjusting levels**
- **110 option available**

### Serial Digital Input

Signal Type	SMPTE 259
EDH	Fully compliant
Impedance	75 $\Omega$
Return Loss	>15 dB
Max Cable Length	300 meters Belden 1694A
Automatic Cable Input Equalization	

### Reference Input

Number	Two: One external (modules BNC) One internal (frame master ref BNC)
Type	1 V P-P Composite Video, PAL or NTSC
Impedance	75 $\Omega$
Return Loss	>40 dB

### Analog Output

Type	PAL or NTSC 4 composite and 1 Y/C or 2 composite and 1 component Y, Pr, Pb or RGB
Impedance	75 $\Omega$
Return Loss	>40 dB
Output DC	<50 mV
Delay	1 line, adjustable up to 1 frame

### SDI to Analog Performance

Bit Resolution	12 bit output reconstruction 8 x oversampling
Signal to Noise	>65 dB
Frequency Response	$\pm 0.1$ dB, 0 to 5.5 MHz
K Factor	<1%
ScH Phase Error	< $\pm 2$ degrees
Differential Phase	<1 degree
Differential Gain	<1%
Color Field Sequence	Locked to selected Ref

### AES/EBU Digital Inputs (6230 sub module)

Number	Two (total of four channels)
Type	AES3id
Connector	Coaxial, 75 $\Omega$
Bit Depth	20 or 24 bit
Sample Rate	30 kHz to 100 kHz (sample rate converted internally to 48 kHz)
Crosstalk	<144 dB
Dynamic Range	>144 dB
Reference Level	-18 or -20 dBFS (selectable)
AC-3, Dolby E	Supported when inputs are synchronous

### Embedded Inputs (6230)

Number	One (from SDI video input)
Type	SMPTE 274M compliant Selectable to any of 4 groups
Channels	Four
Bit Depth	20 and 24 bit

### Analog Audio Output (6230)

Analog Output	Four, Balanced Pair
Processing	24 Bits
Analog Output Z	30 $\Omega$ , balanced, transformerless
Max Output level	+24 dBu
Dynamic Range	>106 dB

### General Specifications

Power Consumption	10 watts (with both options installed)
Temperature	0 to 40°C, ambient (all specs met)
Relative Humidity	0 to 95%, noncondensing
Altitude	0 to 10,000 ft